

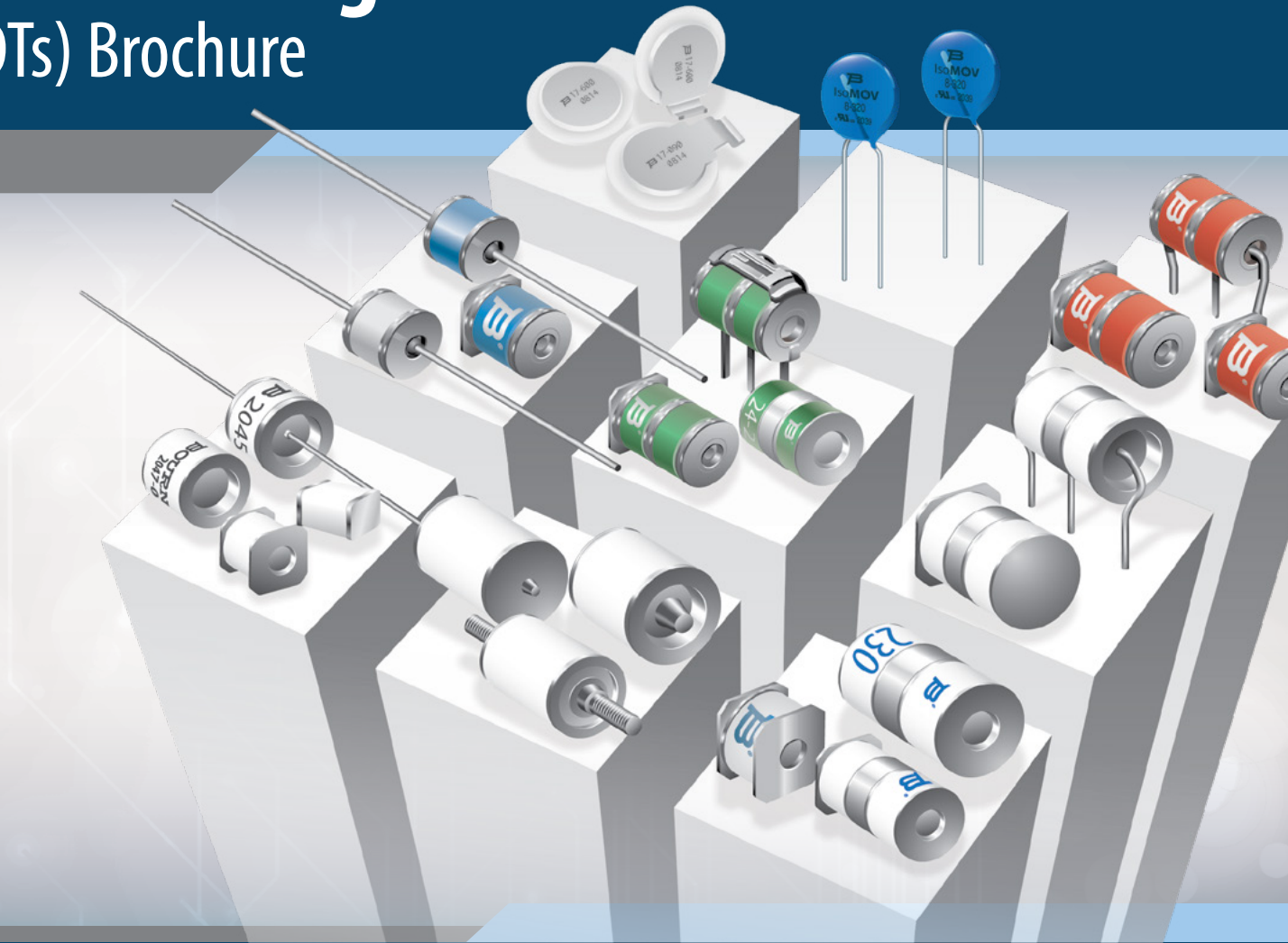

Gas Discharge Tubes (GDTs) Brochure



BOURNS®



Bourns® GDT Product Overview



Introduction

Bourns delivers a comprehensive line of circuit protection technologies and solutions. At our engineering centers in Riverside, California and Linkou, Taiwan, we design a full range of overvoltage and overcurrent protection technologies.

Bourns offers world-class technology and application expertise that is the result of many years of circuit protection engineering, design and support. Bourns' global reputation for extensive application knowledge, quality products, innovative protection strategies and a wide range of technologies ensures that we can provide the right circuit protection solution for your needs.

Customers across different markets and industries have come to rely on Bourns® Gas Discharge Tube (GDT) Surge Arrestors to protect an ever-increasing variety of electronic equipment. Bourns® GDT technology offers fast response times, low capacitance, long service life and high surge current handling capabilities. Bourns engineers continue to innovate GDT technology by designing ground-breaking GDT designs such as the industry-leading GDT Series with FLAT® technology.

Bourns® GDT Product Features

- RoHS compliant*
- Wide range of voltages available (75 V to 7200 V)
- Wide range of sizes available
- Patented hybrid technology designs (IsoMOV™, MSP® GDT)
- Low arc (on-state) voltage
- Low capacitance and insertion loss
- Non-radioactive materials
- Devices are tested according to U.S.A. and International standards and recommendations
- Low work function designs that result in long and stable service life
- Patented Switch-Grade Fail-Short technology available on some models

Bourns® GDT Benefits

- 50+ years of designing and manufacturing GDT devices
- Impulse current ratings (2 kA to 100 kA)
- Low capacitance and insertion loss
- Designs based on industry standards
- Technical committee participation and leadership
- Custom device capabilities
- Lab facilities available for design verification of customer circuits as well as with testing capabilities for UL and Telcordia standards

Benefits of Partnering with Bourns for your GDT Circuit Protection Needs

- Special leadform and voltage screening capabilities
- Technical design support
- Bourns offers multiple circuit protection components for total design support including Thyristors, Diodes, Multifuse® PPTCs, CPTCs, TBU® High-Speed Protectors, Telefuse™ Telecom Protectors, MOVs and Magnetics.

GDT Operation

GDT surge arrester devices are designed to operate on the gas-physical principle of the highly effective arc discharge. Essentially a voltage dependent switch, the GDT maintains a high impedance off-state until a voltage exceeds the device's sparkover voltage. At this point, the gas in the GDT becomes fully ionized and conduction takes place within a fraction of a microsecond.

During arc-over, the GDT exhibits the low impedance of a crowbar device resulting in very low on-state voltage (arc voltage). The crowbar effect of the GDT effectively limits the overvoltage to a low level and shunts the associated follow current away from downstream components and circuitry. When the surge event subsides and the system voltage returns to normal levels, the GDT will reset into its high impedance (off) state.

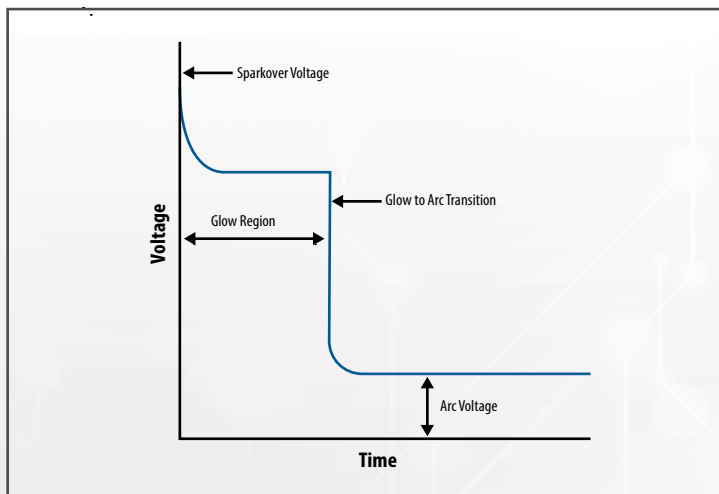

Figure 1 | GDT Voltage Breakdown Characteristic

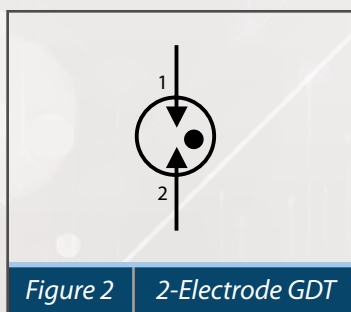

Figure 2 | 2-Electrode GDT

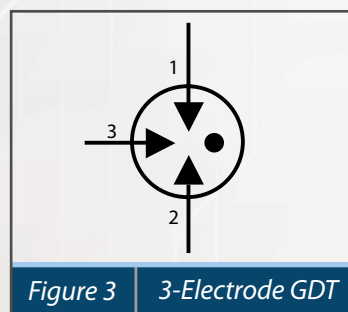

Figure 3 | 3-Electrode GDT

Switch-Grade Fail-Short Devices

Bourns offers a Switch-Grade Fail-Short mechanism available on selected Bourns® GDTs.

- The fail-short contacts are spring-loaded switch-grade electrical conductors with no insulating burn through media or solder pellets under compression.
- The fail-short mechanism is activated by a breakaway action, preventing solder residues from freezing the fail-short mechanism and diurnal temperature failures.
- Superior thermal coupling between the Switch-Grade Fail-Short device and suppression components allows rapid Fail-Short activation in both vented and non-vented GDTs, with one of the industry's lowest contact resistance.
- Available on Model 2026, 2036 and 2026 MSP® Series GDTs..

Fully Integrated IsoMOV™ Hybrid Protector

Bourns offers a complete series of IsoMOV™ hybrid protectors designed with an MOV and GDT isolation structure. In this configuration, the GDT blocks leakage currents through the MOV that would otherwise lead to premature failure of the MOV device, while the MOV prevents the follow-on current (after a surge) that might damage the GDT.

GDT Types

Bourns offers a broad range of 2-electrode and 3-electrode GDT devices (figures 2 & 3). 2-electrode devices are typically used to provide line to ground or line to line protection (1 to 2). In a single device, a 3-electrode GDT can provide protection from line to line (1-2) as well as line to ground (1 to 3, 2 to 3) in a single device.

Standard GDTs (75 to 600 V) are provided in both 2- and 3-electrode devices. High voltage GDTs (800 to 7200 V) are primarily offered in 2-electrode devices and some select 3-electrode packages. In addition, specialized GDTs are offered in high current, fast acting, hybrid and FLAT® technology versions allowing the customer to address a wider array of protection needs.

Bourns® GDT Application Overview

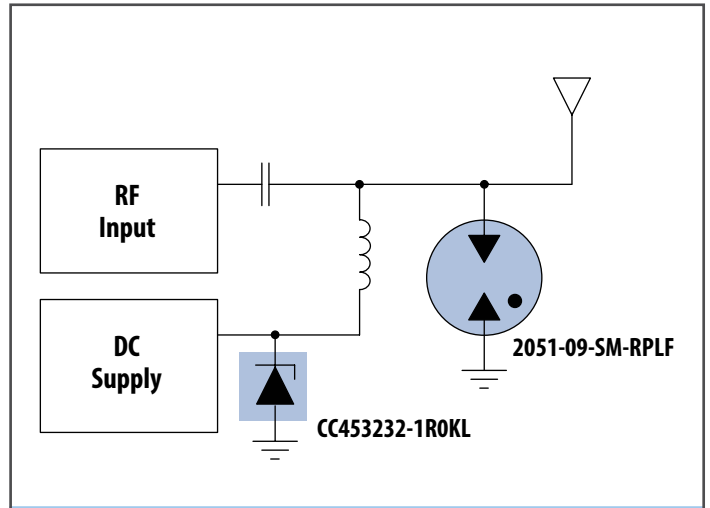

Figure 4 Satellite Receiver RF Input

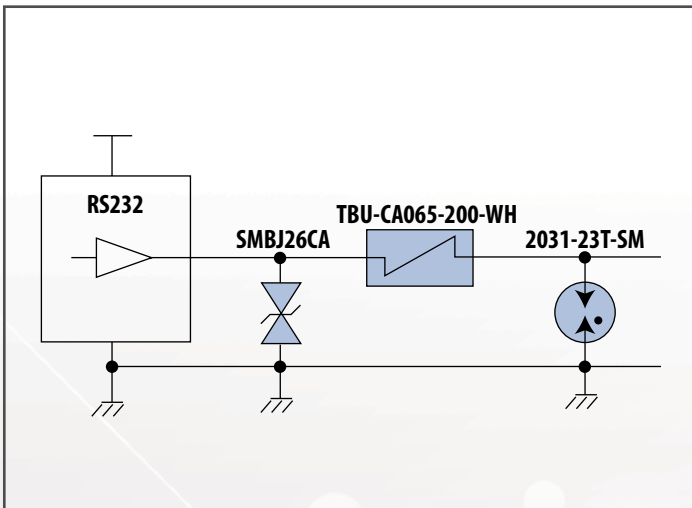

Figure 5 RS-232 Serial Port Surge Protection

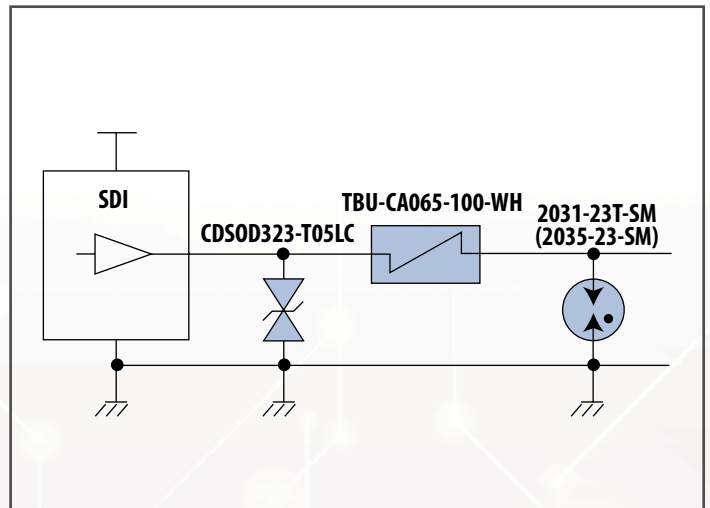

Figure 6 Video Surveillance

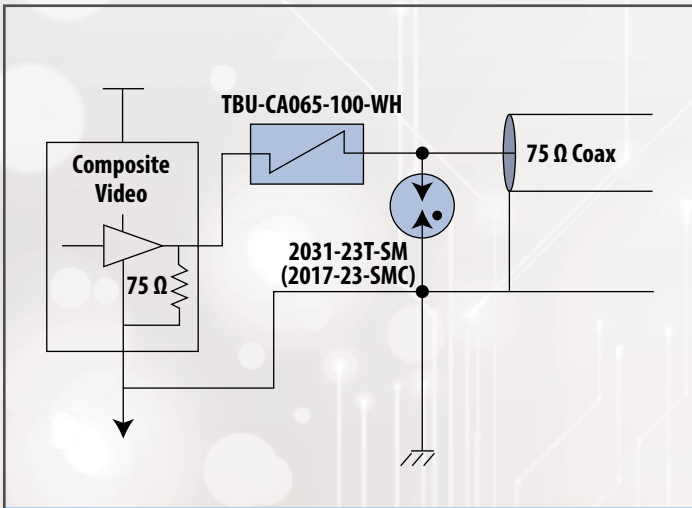
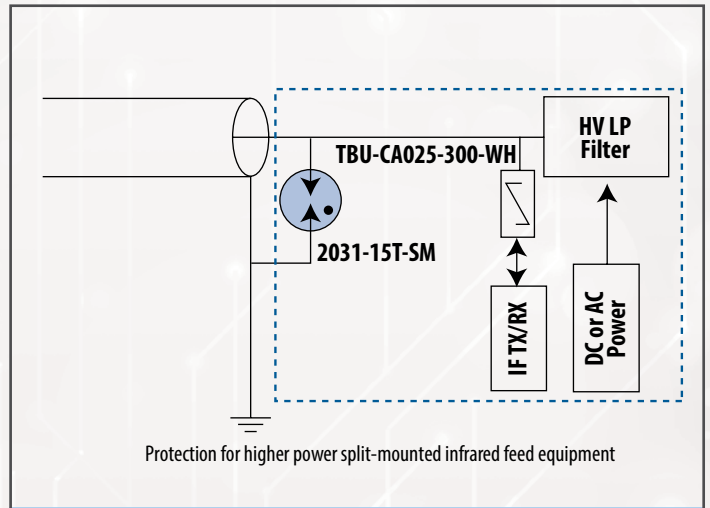

Figure 7 Intelligent Transport System



Protection for higher power split-mounted infrared feed equipment

Figure 8 Microwave Link

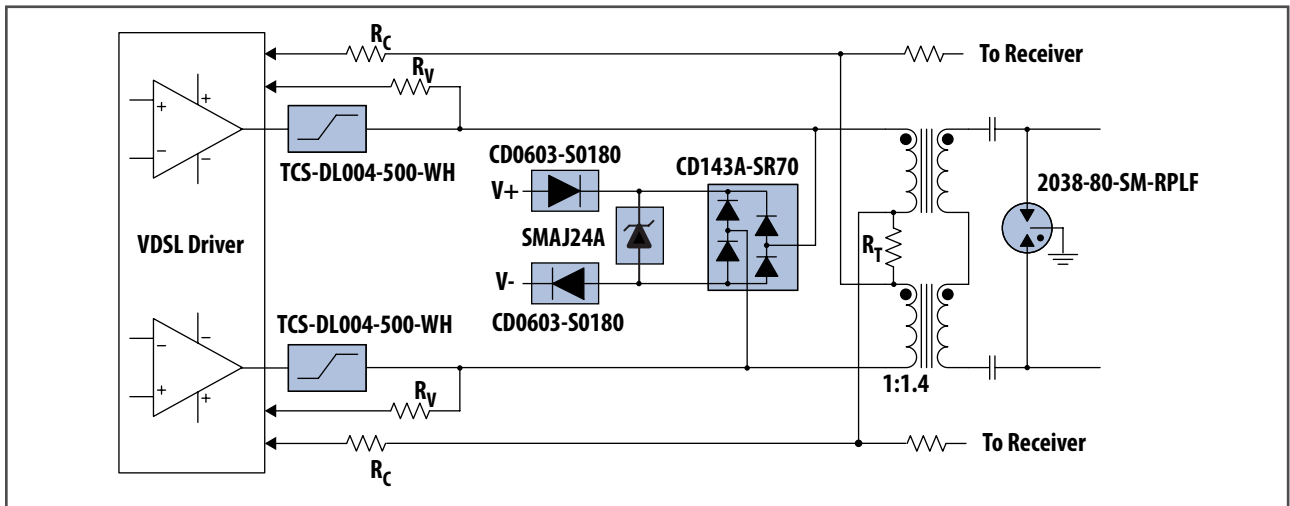

Figure 9 VDSL Class H Driver – Fully Resettable GR-1089 ISSUE 6 Solution for Port Types 1, 3, and 5

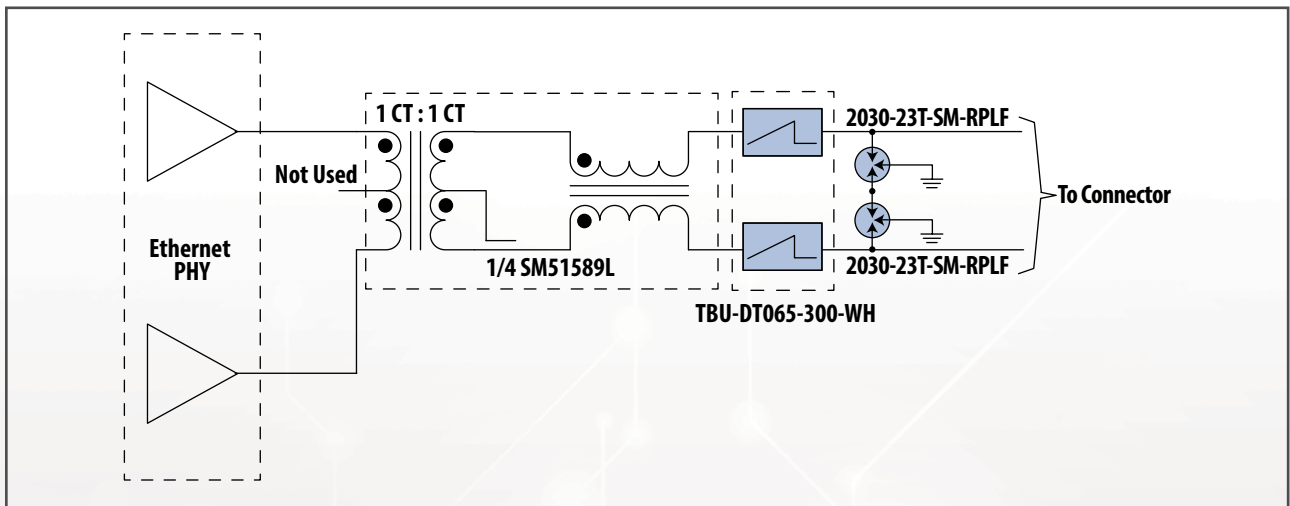

Figure 10 Ethernet Surge and Power Cross Protection – GR-1089 ISSUE 6, Port Type 4

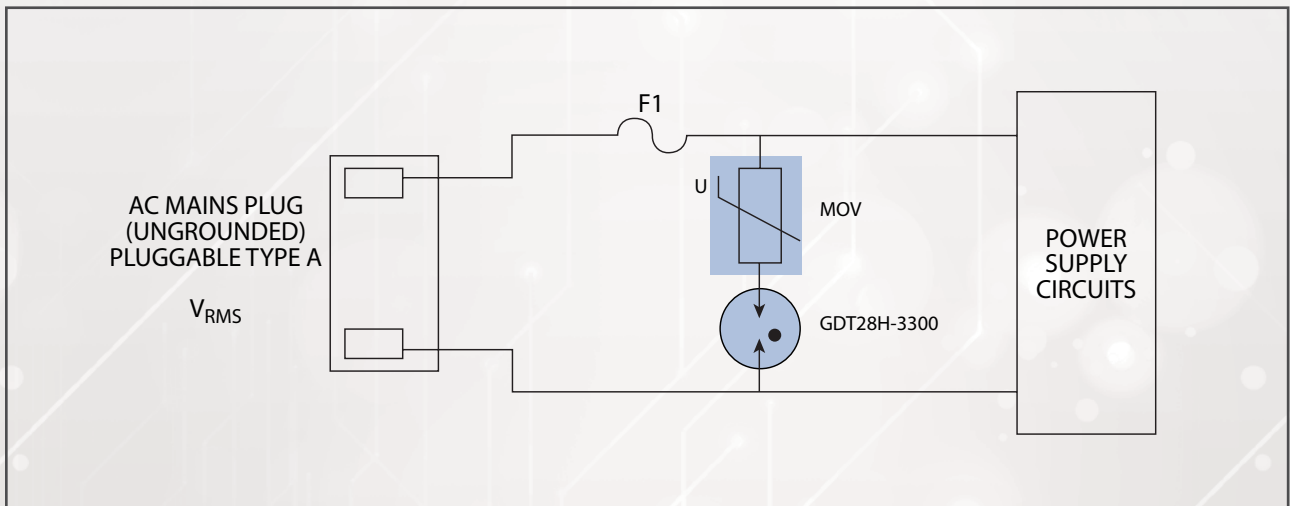

Figure 11 Schematic for Common Mode Protection according with UL/IEC 62368-1 Compliance

GDT General Information

Quality Systems

Bourns® GDTs* are produced in ISO 9001, ISO 14001 and TS16949 certified facilities.

Quality and Reliable Monitoring

Bourns® GDTs are 100 % production tested to assure compliance of critical product parameters. In addition, GDTs are periodically subjected to ongoing reliability and requalification testing as demanded by our quality system requirements.

Quality Sampling Inspections

Bourns® GDTs are inspected to AQL 0.65, DIN ISO 2859 specifications.

Operating and Storage Conditions

Bourns® GDT devices comply with the general operating and storage conditions as detailed in ITU K.12 (-40 °C to +85 °C) unless otherwise specified in the product series data sheet.

*Specific GDT series are offered with an **extended temperature range** for more demanding environments and requirements.*

Performance by Design

Bourns® GDT device designs are based on standard ITU-T K.12, as well as key considerations of RUS-PE80/IEEE C62.31, GR-1361, GR-974, GR-1089, ITU-T K.20/21, IEC61643-311 (EN61643-311), and DIN VDE 0845 part 2.

UL Listing

Bourns® GDTs are UL recognized to one of the following standards:

- UL 497B
- UL 1449

Information regarding specific products series can be found in the following UL Recognition files:

- E153537
- E313168

Regulated Substances

Bourns® GDTs with an “LF” designator are RoHS compliant as defined in the RoHS Directive 2015/863, Mar 31, 2015 and Annex.

By definition, Bourns® GDTs and Switch-Grade Fail-Short option with an “LF” suffix are below maximum concentration values (no exemptions used) for:

- Lead
- Cadmium
- Hexavalent Chromium
- Mercury and Mercury Compounds
- PBBs and PBDEs

* depending on model type

GDTs with FLAT® Technology

2017-xx-SMC		2-Electrode SMD GDT with FLAT® Technology						
Size (mm)	DC Breakdown Range (V)	Nominal 8/20 μ s Impulse Discharge Current (kA) 10 Applications	Maximum 8 x 20 μ s Impulse Current (kA) 1 Application	Maximum 10 x 350 μ s Impulse Current (kA) 1 Application	Capacitance (pF)	Operating Temperature Range (°C)	Packaging Options	
See data sheet	90 - 500	10	12	2.5	< 2.5	-55 to +85	Tape & Reel Bulk	
2017-xx-SMH		2-Electrode SMD GDT with FLAT® Technology						
Size (mm)	DC Breakdown Range (V)	Nominal 8/20 μ s Impulse Discharge Current (kA) 10 Applications	Maximum 8 x 20 μ s Impulse Current (kA) 1 Application	Maximum 10 x 350 μ s Impulse Current (kA) 1 Application	Capacitance (pF)	Operating Temperature Range (°C)	Packaging Options	
See data sheet	90 - 500	10	12	2.5	< 2.5	-55 to +85	Tape & Reel Bulk	
2018-xx-SMH		3-Electrode SMD GDT with FLAT® Technology						
Size (mm)	DC Breakdown Range (V)	Nominal 8/20 μ s Impulse Discharge Current (kA) 10 Applications	Maximum 8 x 20 μ s Impulse Current (kA) 1 Application	Maximum 10 x 350 μ s Impulse Current (kA) 1 Application	Capacitance (pF)	Operating Temperature Range (°C)	Packaging Options	
See data sheet	90 - 500	20	24	5	< 2.5	-55 to +105	Tape & Reel	
2019-xx-SMH		2-Electrode SMD GDT with FLAT® Technology						
Size (mm)	DC Breakdown Range (V)	Nominal 8/20 μ s Impulse Discharge Current (kA) 10 Applications	Maximum 8 x 20 μ s Impulse Current (kA) 1 Application	Maximum 10 x 350 μ s Impulse Current (kA) 1 Application	Capacitance (pF)	Operating Temperature Range (°C)	Packaging Options	
See data sheet	90 - 230	20	25	5	< 4	-55 to +105	Tape & Reel	

Powerline GDT

2033-xx-G5		Powerline GDT						
Size (mm)	DC Breakdown Range (V)	Nominal 8/20 μ s Impulse Discharge Current (kA) 10 Applications	Maximum 8 x 20 μ s Impulse Current (kA) 1 Application	Maximum 10 x 350 μ s Impulse Current (kA) 1 Application	Capacitance (pF)	Operating Temperature Range (°C)	Packaging Options	
See data sheet	800 - 1400	20, 10 Operations	N/A	4	< 1	-40 to +125	Tape & Bulk	

2-Electrode Standard Surface Mount (SMD) GDTs

2003-xx-SM

Light Duty Miniature GDT



Size (mm)	DC Breakdown Range (V)	Nominal 8/20 μ s Impulse Discharge Current (kA) 10 Applications	Maximum 8 x 20 μ s Impulse Current (kA) 1 Application	Maximum 10 x 350 μ s Impulse Current (kA) 1 Application	Capacitance (pF)	Operating Temperature Range (°C)	Packaging Options
See data sheet	75 - 470	1	2	Not Rated	< 0.5	-40 to +90	Tape & Reel

2051-xx-SM

Light Duty Micro Duty GDT - *Extended Temperature Range*



Size (mm)	DC Breakdown Range (V)	Nominal 8/20 μ s Impulse Discharge Current (kA) 10 Applications	Maximum 8 x 20 μ s Impulse Current (kA) 1 Application	Maximum 10 x 350 μ s Impulse Current (kA) 1 Application	Capacitance (pF)	Operating Temperature Range (°C)	Packaging Options
See data sheet	90 - 600	2	Not Rated	Not Rated	< 1	-40 to +125	Tape & Reel Bulk

2053-xx-SM

Light Duty Miniature GDT



Size (mm)	DC Breakdown Range (V)	Nominal 8/20 μ s Impulse Discharge Current (kA) 10 Applications	Maximum 8 x 20 μ s Impulse Current (kA) 1 Application	Maximum 10 x 350 μ s Impulse Current (kA) 1 Application	Capacitance (pF)	Operating Temperature Range (°C)	Packaging Options
See data sheet	75 - 600	3	5	Not Rated	< 1	-30 to +85	Tape & Reel Bulk

2035-xx-SM

Long Life Medium Duty Miniature GDT



Size (mm)	DC Breakdown Range (V)	Nominal 8/20 μ s Impulse Discharge Current (kA) 10 Applications	Maximum 8 x 20 μ s Impulse Current (kA) 1 Application	Maximum 10 x 350 μ s Impulse Current (kA) 1 Application	Capacitance (pF)	Operating Temperature Range (°C)	Packaging Options
See data sheet	90 - 600	5	10	1	< 1	-55 to +85	Tape & Reel Bulk

2055-xx-SM

Medium Duty Miniature GDT



Size (mm)	DC Breakdown Range (V)	Nominal 8/20 μ s Impulse Discharge Current (kA) 10 Applications	Maximum 8 x 20 μ s Impulse Current (kA) 1 Application	Maximum 10 x 350 μ s Impulse Current (kA) 1 Application	Capacitance (pF)	Operating Temperature Range (°C)	Packaging Options
See data sheet	90 - 600	5	8	Not Rated	< 1	-30 to +85	Tape & Reel Bulk

2027-xx-SM

Long Life Heavy Duty SMD GDT - *Extended Temperature Range*



Size (mm)	DC Breakdown Range (V)	Nominal 8/20 μ s Impulse Discharge Current (kA) 10 Applications	Maximum 8 x 20 μ s Impulse Current (kA) 1 Application	Maximum 10 x 350 μ s Impulse Current (kA) 1 Application	Capacitance (pF)	Operating Temperature Range (°C)	Packaging Options
See data sheet	75 - 600	10	25	2.5	< 1	-55 to +125	Tape & Reel Bulk

2029-xx-SMLF

Long Life Heavy Duty SMD GDT - *Extended Temperature Range*



Size (mm)	DC Breakdown Range (V)	Nominal 8/20 μ s Impulse Discharge Current (kA) 10 Applications	Maximum 8 x 20 μ s Impulse Current (kA) 1 Application	Maximum 10 x 350 μ s Impulse Current (kA) 1 Application	Capacitance (pF)	Operating Temperature Range (°C)	Packaging Options
See data sheet	90 - 420	20	25	5	< 1	-55 to +105	Tape & Reel Bulk

2-Electrode Standard Through-Hole GDTs

2057-xx-XX		Medium Duty Through-Hole Micro GDT						
Size (mm)	DC Breakdown Range (V)	Nominal 8/20 μ s Impulse Discharge Current (kA) 10 Applications	Maximum 8 x 20 μ s Impulse Current (kA) 1 Application	Maximum 10 x 350 μ s Impulse Current (kA) 1 Application	Capacitance (pF)	Operating Temperature Range ($^{\circ}$ C)	Packaging Options	
See data sheet	75 - 470	5	10	Not Rated	< 1	-40 to +90	Tape & Reel Bulk	

2035-xx-XX		Long Life Medium Duty Through-Hole Miniature GDT						
Size (mm)	DC Breakdown Range (V)	Nominal 8/20 μ s Impulse Discharge Current (kA) 10 Applications	Maximum 8 x 20 μ s Impulse Current (kA) 1 Application	Maximum 10 x 350 μ s Impulse Current (kA) 1 Application	Capacitance (pF)	Operating Temperature Range ($^{\circ}$ C)	Packaging Options	
See data sheet	90 - 600	5	10	1	< 1	-55 to +85	Tape & Reel Bulk	

2037-xx-XX		Long Life Medium Duty Through-Hole Miniature GDT						
Size (mm)	DC Breakdown Range (V)	Nominal 8/20 μ s Impulse Discharge Current (kA) 10 Applications	Maximum 8 x 20 μ s Impulse Current (kA) 1 Application	Maximum 10 x 350 μ s Impulse Current (kA) 1 Application	Capacitance (pF)	Operating Temperature Range ($^{\circ}$ C)	Packaging Options	
See data sheet	90 - 600	5	10	1	< 1	-55 to +85	Tape & Reel Bulk	

2045-xx-XX		Medium Duty Through-Hole GDT						
Size (mm)	DC Breakdown Range (V)	Nominal 8/20 μ s Impulse Discharge Current (kA) 10 Applications	Maximum 8 x 20 μ s Impulse Current (kA) 1 Application	Maximum 10 x 350 μ s Impulse Current (kA) 1 Application	Capacitance (pF)	Operating Temperature Range ($^{\circ}$ C)	Packaging Options	
See data sheet	75 - 470	10	15	Not Rated	< 1.5	-30 to +85	Tape & Reel Bulk	

2049-xx-XX		Heavy Duty Through-Hole GDT						
Size (mm)	DC Breakdown Range (V)	Nominal 8/20 μ s Impulse Discharge Current (kA) 10 Applications	Maximum 8 x 20 μ s Impulse Current (kA) 1 Application	Maximum 10 x 350 μ s Impulse Current (kA) 1 Application	Capacitance (pF)	Operating Temperature Range ($^{\circ}$ C)	Packaging Options	
See data sheet	75 - 600	15	20	Not Rated	< 1.5	-30 to +85	Tape & Reel Bulk	

2027-xx-XX		Long Life Heavy Duty Through-Hole GDT - <i>Extended Temperature Range</i>						
Size (mm)	DC Breakdown Range (V)	Nominal 8/20 μ s Impulse Discharge Current (kA) 10 Applications	Maximum 8 x 20 μ s Impulse Current (kA) 1 Application	Maximum 10 x 350 μ s Impulse Current (kA) 1 Application	Capacitance (pF)	Operating Temperature Range ($^{\circ}$ C)	Packaging Options	
See data sheet	75 - 600	10	25	2.5	< 1	-55 to +125	Tape & Reel Bulk	

2-Electrode High Voltage GDTs

2087-xxx-SM High Voltage Miniature SMD GDT							
	Size (mm)	DC Breakdown Range (V)	Nominal 8/20 μs Impulse Discharge Current (kA) 10 Operations	Maximum 8 x 20 μs Impulse Current (kA) 1 Application	Capacitance (pF)	Operating Temperature Range ($^{\circ}$C)	Packaging Options
See data sheet	800 - 2000	2	3	< 0.5	-30 to +85	Tape & Reel Bulk	
2039-xxx-XX High Voltage Miniature Through-Hole GDT							
	Size (mm)	DC Breakdown Range (V)	Nominal 8/20 μs Impulse Discharge Current (kA) 10 Operations	Maximum 8 x 20 μs Impulse Current (kA) 1 Application	Capacitance (pF)	Operating Temperature Range ($^{\circ}$C)	Packaging Options
See data sheet	800 - 1100	2.5	5	< 1	-55 to +85	Tape & Reel Bulk	
2039-xxx-SM High Voltage Miniature SMD GDT							
	Size (mm)	DC Breakdown Range (V)	Nominal 8/20 μs Impulse Discharge Current (kA) 10 Operations	Maximum 8 x 20 μs Impulse Current (kA) 1 Application	Capacitance (pF)	Operating Temperature Range ($^{\circ}$C)	Packaging Options
See data sheet	900 - 1100	2.5	5	< 1	-55 to +85	Tape & Reel Bulk	
2089-xxx-XX High Voltage Miniature Through-Hole GDT							
	Size (mm)	DC Breakdown Range (V)	Nominal 8/20 μs Impulse Discharge Current (kA) 10 Operations	Maximum 8 x 20 μs Impulse Current (kA) 1 Application	Capacitance (pF)	Operating Temperature Range ($^{\circ}$C)	Packaging Options
See data sheet	1000 - 3600	1.5	3	< 1.5	-30 to +85	Tape & Reel Bulk	
2093-xxx-SM High Voltage SMD GDT							
	Size (mm)	DC Breakdown Range (V)	Nominal 8/20 μs Impulse Discharge Current (kA) 10 Operations	Maximum 8 x 20 μs Impulse Current (kA) 1 Application	Capacitance (pF)	Operating Temperature Range ($^{\circ}$C)	Packaging Options
See data sheet	1000 - 3000	3	5	< 0.8	-30 to +85	Tape & Reel Bulk	
2095-xxx-XX High Voltage Through-Hole GDT							
	Size (mm)	DC Breakdown Range (V)	Nominal 8/20 μs Impulse Discharge Current (kA) 10 Operations	Maximum 8 x 20 μs Impulse Current (kA) 1 Application	Capacitance (pF)	Operating Temperature Range ($^{\circ}$C)	Packaging Options
See data sheet	800 - 6000	5 / 3	8 / 5	< 1.5	-30 to +90	Tape & Reel Bulk	
2097-xxx-D Heavy Duty High Voltage Through-Hole GDT							
	Size (mm)	DC Breakdown Range (V)	Nominal 8/20 μs Impulse Discharge Current (kA) 10 Operations	Maximum 8 x 20 μs Impulse Current (kA) 1 Application	Capacitance (pF)	Operating Temperature Range ($^{\circ}$C)	Packaging Options
See data sheet	1000 - 2200	20 5 Operations	25	< 1	-30 to +85	Bulk	
SA2-xxxx-xxx-STD High Voltage Through-Hole GDT - <i>Extended Temperature Range</i>							
	Size (mm)	DC Breakdown Range (V)	Nominal 8/20 μs Impulse Discharge Current (kA) 10 Operations	Maximum 8 x 20 μs Impulse Current (kA) 1 Application	Capacitance (pF)	Operating Temperature Range ($^{\circ}$C)	Packaging Options
See data sheet	2000 - 7200	5	10	< 1	-40 to +125	Tape & Reel Bulk	
GDT28-xxx-xxx Next-Generation Compact High Voltage Through-Hole GDT							
	Size (mm)	DC Breakdown Range (V)	Nominal 8/20 μs Impulse Discharge Current (kA) 10 Operations	Maximum 8 x 20 μs Impulse Current (kA) 2 Operations	AC Withstand Voltage (V_{rms}) 3 min	Capacitance (pF)	Operating Temperature Range ($^{\circ}$C)
See data sheet	1000 - 3300	5	10	510 - 1680	< 1.5	-40 $^{\circ}$ C to +125	Tape & Reel Bulk

2-Electrode High Current GDTs

2047-xx-XX		Long Life High Current Heavy Duty GDT						
Size (mm)	DC Breakdown Range (V)	Nominal 8/20 μ s Impulse Discharge Current (kA)	Maximum 8 x 20 μ s Impulse Current (kA) 1 Application	Maximum 10 x 350 μ s Impulse Current (kA) 1 Application	Capacitance (pF)	Operating Temperature Range ($^{\circ}$ C)	Packaging Options	
See data sheet	90 - 350	40 10 Operations	40	8	< 5	-40 to +90	Bulk	

2061-xx-A		High Current Heavy Duty 2-Electrode GDT						
Size (mm)	DC Breakdown Range (V)	Nominal 8/20 μ s Impulse Discharge Current (kA)	Maximum 8 x 20 μ s Impulse Current (kA) 1 Application	Maximum 10 x 350 μ s Impulse Current (kA) 1 Application	Capacitance (pF)	Operating Temperature Range ($^{\circ}$ C)	Packaging Options	
See data sheet	230 - 800	40 5 Operations	60	Not Rated	< 10	-30 to +85	Bulk	

2063-xx-A		High Current Heavy Duty 2-Electrode GDT						
Size (mm)	DC Breakdown Range (V)	Nominal 8/20 μ s Impulse Discharge Current (kA)	Maximum 8 x 20 μ s Impulse Current (kA) 1 Application	Maximum 10 x 350 μ s Impulse Current (kA) 1 Application	Capacitance (pF)	Operating Temperature Range ($^{\circ}$ C)	Packaging Options	
See data sheet	230 - 800	60 5 Operations	100	Not Rated	< 10	-30 to +85	Bulk	

2-Electrode High Energy GDTs

GDT212E-xx-A		High Energy Gas Discharge Tube Arrestor 12 mm Diameter						
Size (mm)	DC Breakdown Range (V)	Nominal 8/20 μ s Impulse Discharge Current (kA)	Maximum 8 x 20 μ s Impulse Current (kA) 1 Application	Maximum 10 x 350 μ s Impulse Current (kA) 1 Application	Minimum Insulation Resistance	Operating Temperature Range ($^{\circ}$ C)	Packaging Options	
12	230 - 800	30 10 Operations	40	8	1 G Ω	-55 $^{\circ}$ C to +105	Box	

GDT216E-xx-A		High Energy Gas Discharge Tube Arrestor 16 mm Diameter						
Size (mm)	DC Breakdown Range (V)	Nominal 8/20 μ s Impulse Discharge Current (kA)	Maximum 8 x 20 μ s Impulse Current (kA) 1 Application	Maximum 10 x 350 μ s Impulse Current (kA) 1 Application	Minimum Insulation Resistance	Operating Temperature Range ($^{\circ}$ C)	Packaging Options	
16	500 - 800	20 10 Operations	40	8	1 G Ω	-55 $^{\circ}$ C to +105	Box	

GDT220E-xx-A		High Energy Gas Discharge Tube Arrestor 20 mm Diameter						
Size (mm)	DC Breakdown Range (V)	Nominal 8/20 μ s Impulse Discharge Current (kA)	Maximum 8 x 20 μ s Impulse Current (kA) 1 Application	Maximum 10 x 350 μ s Impulse Current (kA) 1 Application	Minimum Insulation Resistance	Operating Temperature Range ($^{\circ}$ C)	Packaging Options	
20	150 - 1000	40 10 Operations	60	12.5	1 G Ω	-55 $^{\circ}$ C to +105	Box	



GDT225E-xx-A		High Energy Gas Discharge Tube Arrestor 25 mm Diameter						
Size (mm)	DC Breakdown Range (V)	Nominal 8/20 μ s Impulse Discharge Current (kA)	Maximum 8 x 20 μ s Impulse Current (kA) 1 Application	Maximum 10 x 350 μ s Impulse Current (kA) 1 Application	Minimum Insulation Resistance	Operating Temperature Range ($^{\circ}$ C)	Packaging Options	
25	500 - 800	60 10 Operations	80	30	1 G Ω	-55 $^{\circ}$ C to +105	Box	

3-Electrode Standard SMD GDTs

2052-xx-SM Light Duty Symmetrical Miniature SMD GDT								
	Size (mm)	DC Breakdown Range (V)	Nominal 8/20 μ s Impulse Discharge Current (kA) 10 Applications*	Maximum 8 x 20 μ s Impulse Current (kA) 1 Application*	Maximum 10 x 350 μ s Impulse Current (kA) 1 Application*	Capacitance (pF)	Operating Temperature Range ($^{\circ}$ C)	Packaging Options
	See data sheet	230 - 600	5	10	Not Rated	< 2	-30 to +85	Tape & Reel, Bulk
2054-xx-SM Light Duty Miniature SMD GDT								
	Size (mm)	DC Breakdown Range (V)	Nominal 8/20 μ s Impulse Discharge Current (kA) 10 Applications*	Maximum 8 x 20 μ s Impulse Current (kA) 1 Application*	Maximum 10 x 350 μ s Impulse Current (kA) 1 Application*	Capacitance (pF)	Operating Temperature Range ($^{\circ}$ C)	Packaging Options
	See data sheet	230 - 470	5	Not Rated	Not Rated	< 2	-30 to +85	Tape & Reel, Bulk
2038-xx-SM Long Life Light Duty Symmetrical Miniature SMD GDT								
	Size (mm)	DC Breakdown Range (V)	Nominal 8/20 μ s Impulse Discharge Current (kA) 10 Applications*	Maximum 8 x 20 μ s Impulse Current (kA) 1 Application*	Maximum 10 x 350 μ s Impulse Current (kA) 1 Application*	Capacitance (pF)	Operating Temperature Range ($^{\circ}$ C)	Packaging Options
	See data sheet	150 - 600	5	10	Not Rated	< 1	-40 to +90	Tape & Reel, Bulk
2036-xx-SM Long Life Medium Duty Miniature SMD GDT - <i>Extended Temperature Range</i>								
	Size (mm)	DC Breakdown Range (V)	Nominal 8/20 μ s Impulse Discharge Current (kA) 10 Applications*	Maximum 8 x 20 μ s Impulse Current (kA) 1 Application*	Maximum 10 x 350 μ s Impulse Current (kA) 1 Application*	Capacitance (pF)	Operating Temperature Range ($^{\circ}$ C)	Packaging Options
	See data sheet	75 - 600	10	20	2	< 2	-55 to +105	Tape & Reel, Bulk
2036-xx-SM-H Long Life Medium Duty Miniature SMD GDT - <i>High Temperature Range</i>								
	Size (mm)	DC Breakdown Range (V)	Nominal 8/20 μ s Impulse Discharge Current (kA) 10 Applications*	Maximum 8 x 20 μ s Impulse Current (kA) 1 Application*	Maximum 10 x 350 μ s Impulse Current (kA) 1 Application*	Capacitance (pF)	Operating Temperature Range ($^{\circ}$ C)	Packaging Options
	See data sheet	75 - 600	10	20	2	< 2	-55 to +125	Tape & Reel, Bulk

*The rated current is the total current equally divided between each line to ground (ELTG).

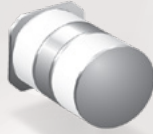
3-Electrode High Voltage SMD GDTs

2052-xx-SM High Voltage Symmetrical Miniature SMD GDT								
	Size (mm)	DC Breakdown Range (V)	Nominal 8/20 μ s Impulse Discharge Current (kA) 10 Applications*	Maximum 8 x 20 μ s Impulse Current (kA) 1 Application*	Maximum 10 x 350 μ s Impulse Current (kA) 1 Application*	Capacitance (pF)	Operating Temperature Range ($^{\circ}$ C)	Packaging Options
	See data sheet	800	5	10	Not Rated	< 2	-30 to +85	Tape & Reel
2038-xx-SM High Voltage Symmetrical Miniature SMD GDT								
	Size (mm)	DC Breakdown Range (V)	Nominal 8/20 μ s Impulse Discharge Current (kA) 10 Applications*	Maximum 8 x 20 μ s Impulse Current (kA) 1 Application*	Maximum 10 x 350 μ s Impulse Current (kA) 1 Application*	Capacitance (pF)	Operating Temperature Range ($^{\circ}$ C)	Packaging Options
	See data sheet	800, 1100	5	10	Not Rated	< 1	-40 to +90	Tape & Reel, Bulk

3-Electrode Standard Through-Hole GDTs

2056-xx-XX		Light Duty Through-Hole GDT							
Size (mm)	Optional Fail-Short	DC Breakdown Range (V)	Nominal 8/20 μ s Impulse Discharge Current (kA) 10 Applications*	Max. 8 x 20 μ s Impulse Current (kA) 1 Application*	Max. 10 x 350 μ s Impulse Current (kA) 1 Application*	Capacitance (pF)	Operating Temperature Range ($^{\circ}$ C)	Packaging Options	
See data sheet	Yes	90 - 600	5	Not Rated	Not Rated	< 2	-30 to +85	Bulk	

2046-xx-XX		Medium Duty Through-Hole GDT							
Size (mm)	Optional Fail-Short	DC Breakdown Range (V)	Nominal 8/20 μ s Impulse Discharge Current (kA) 10 Applications*	Max. 8 x 20 μ s Impulse Current (kA) 1 Application*	Max. 10 x 350 μ s Impulse Current (kA) 1 Application*	Capacitance (pF)	Operating Temperature Range ($^{\circ}$ C)	Packaging Options	
See data sheet	Yes	90 - 600	10	20	Not Rated	< 2	-30 to +85	Bulk	

2036-xx-XX		Long Life Medium Duty Miniature Through-Hole GDT - <i>Extended Temperature Range</i>							
Size (mm)	Optional Fail-Short	DC Breakdown Range (V)	Nominal 8/20 μ s Impulse Discharge Current (kA) 10 Applications*	Max. 8 x 20 μ s Impulse Current (kA) 1 Application*	Max. 10 x 350 μ s Impulse Current (kA) 1 Application*	Capacitance (pF)	Operating Temperature Range ($^{\circ}$ C)	Packaging Options	
See data sheet	Yes Switch-Grade	75 - 600	10	20	2	< 2	-55 to +105	Bulk	

2026-xx-XX		Long Life Heavy Duty Through-Hole GDT							
Size (mm)	Optional Fail-Short	DC Breakdown Range (V)	Nominal 8/20 μ s Impulse Discharge Current (kA) 10 Applications*	Max. 8 x 20 μ s Impulse Current (kA) 1 Application*	Max. 10 x 350 μ s Impulse Current (kA) 1 Application*	Capacitance (pF)	Operating Temperature Range ($^{\circ}$ C)	Packaging Options	
See data sheet	Yes Switch-Grade	75 - 600	20	40	5	< 2	-40 to +90	Bulk	

2026-xx-XX-MSP		Heavy Duty Multi-Stage Through-Hole GDT							
Size (mm)	Optional Fail-Short	DC Breakdown Range (V)	Nominal 8/20 μ s Impulse Discharge Current (kA) 10 Applications*	Max. 8 x 20 μ s Impulse Current (kA) 1 Application*	Max. 10 x 350 μ s Impulse Current (kA) 1 Application*	Capacitance (pF)	Operating Temperature Range ($^{\circ}$ C)	Packaging Options	
See data sheet	Yes Switch-Grade	300 - 400	20	40	5	< 20	-55 to +85	Bulk	

Fully Integrated IsoMOV™ Hybrid Protectors

IsoMOV™		Hybrid Protection Component			
Size (mm)	Max. Continuous Voltage (V_{rms})	Max. Continuous Voltage (V_{dc})	Peak Single Pulse Current 8/20 μ s (I_{max})	Temperature Rating $^{\circ}$ C	
10mm, 14mm, 20mm	175 – 555 V	225 - 745	6 kA, 10 kA, 15 kA	-40 to +125	

*The rated current is the total current equally divided between each line to ground (ELTG).

2-Electrode & 3-Electrode Fast Acting GDTs

Fast Acting GDT Devices

Bourns has developed a line of fast acting GDTs designed specifically for use with the Bourns® TBU® High-Speed Protector (HSP). These fast acting GDT are designed to limit high-speed impulse voltages to levels below the TBU® HSP peak voltage impulse rating (V_{imp}). Voltages exceeding the TBU® HSP V_{imp} rating may cause damage to the TBU® HSP.

The fast acting GDT and TBU® HSP provide an extremely fast, low voltage let-through protection solution that is well-suited to sensitive electronics susceptible to damage from voltage and current transients.

Fast Acting GDT Advantages

- Designed specifically for the TBU® HSP
- Simplifies designing with the TBU® HSP
- Extremely fast overvoltage protection limiting surges below the V_{imp} of the TBU® HSP
- Low capacitance, making it ideal for high-speed applications
- 2-electrode and 3-electrode designs available
- Optional Switch-Grade Fail-Short available for Model 2030-xxT-SM

2020-xxT	Fast Acting 3-Electrode Miniature Through-Hole GDT						
	Size (mm)	Optional Fail-Short	Min. DC Breakdown Range (V)	Max. 8 x 20 μ s Impulse Current (kA) 1 Application*	Capacitance (pF)	Operating Temperature Range (°C)	Packaging Options
	See data sheet	No	60 - 360	10	< 1	-40 to +90	Bulk

2030-xxT-SM	Fast Acting 3-Electrode Miniature SMD GDT - <i>with optional Fail-Short</i>						
	Size (mm)	Optional Fail-Short	Min. DC Breakdown Range (V)	Max. 8 x 20 μ s Impulse Current (kA) 1 Application*	Capacitance (pF)	Operating Temperature Range (°C)	Packaging Options
	See data sheet	Yes	185, 360	4	< 1	-40 to +90	Tape & Reel Bulk

2031-xxT-SM	Fast Acting 2-Electrode Miniature SMD GDT						
	Size (mm)	Optional Fail-Short	Min. DC Breakdown Range (V)	Max. 8 x 20 μ s Impulse Current (kA) 1 Application*	Capacitance (pF)	Operating Temperature Range (°C)	Packaging Options
	See data sheet	No	60 - 360	1	< 1	-40 to +90	Tape & Reel Bulk

2011-xxT-SM	Fast Acting 2-Electrode SMD GDT with FLAT® Technology						
	Size (mm)	Optional Fail-Short	Min. DC Breakdown (V)	Max. 8 x 20 μ s Impulse Current (kA) 1 Application*	Capacitance (pF)	Operating Temperature Range (°C)	Packaging Options
	See data sheet	No	60	1	< 2.9	-40 to +90	Tape & Reel Bulk

* End of life value for DC breakdown. Fresh devices will have significantly higher DC breakdown when measured.

Next-Generation Fast Acting GDT

GDT25-xx-S1

Next-Generation Fast Acting GDT



Size (mm)	DC Breakdown Range (V)	Nominal 8/20 μ s Impulse Discharge Current (kA) 10 Operations*	Max. 8 x 20 μ s Impulse Current (kA) 1 Operation*	Max. 10 x 350 μ s Impulse Current (kA) 1 Operation*	Capacitance (pF)	Operating Temperature Range (°C)	Packaging Options
See data sheet	75 - 600	7	10	1	< 0.6	-55 to +125	Bulk, Tape and Reel

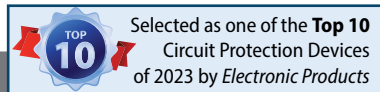

GDT35-xx-S1

Next-Generation Fast Acting GDT



Size (mm)	DC Breakdown Range (V)	Nominal 8/20 μ s Impulse Discharge Current (kA) 10 Operations*	Max. 8 x 20 μ s Impulse Current (kA) 1 Operation*	Max. 10 x 350 μ s Impulse Current (kA) 1 Operation*	Capacitance (pF)	Operating Temperature Range (°C)	Packaging Options
See data sheet	75 - 600	14	20	2	< 0.7 pF (L-G)	-55 to +125	Bulk, Tape and Reel

*The rated current is the total current equally divided between each line to ground (ELTG).

GDTs in Evaluation Boards

This evaluation board serves as an aid in evaluating circuit protection on RS-485 serial device ports using two Bourns® TBU® High-Speed Protectors (HSPs), two fast acting GDTs and two TVS diodes to meet the required industry standards on RS-485 port interfaces. The recommended Bourns® TBU® HSP solution with a low capacitance GDT offers enhanced high-speed performance features over competing technologies, which can help the design engineer increase the surge and transient protection level on RS-485 ports and place the entire circuit protection solution into a smaller reduced PCB area. Bourns has developed an RS-485 evaluation board (measuring 45 mm x 21 mm x 1.2 mm), manufactured using FR4 PCB with nickel gold plating on the top and bottom sides.

** The default configuration of this board uses 2 GDTs (GDT1, GDT2) and discrete SMB TVS diodes (TVS1, TVS2). The board allows different configurations:

- 2 single 2031 GDTs (GDT1 and GDT2) may be replaced by a 2030 GDT (GDT3).
- 2 SMB TVS diodes (TVS1 and TVS2) may be replaced with a) two SOT23 TVS diodes (TVS3, TVS4) or b) a single TVS diode array (TVS5).

See Bourns website for latest updates on evaluation boards and applications notes

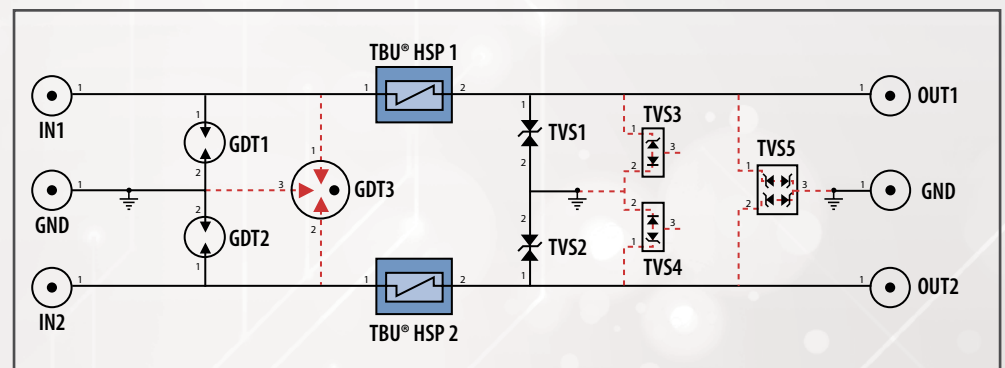
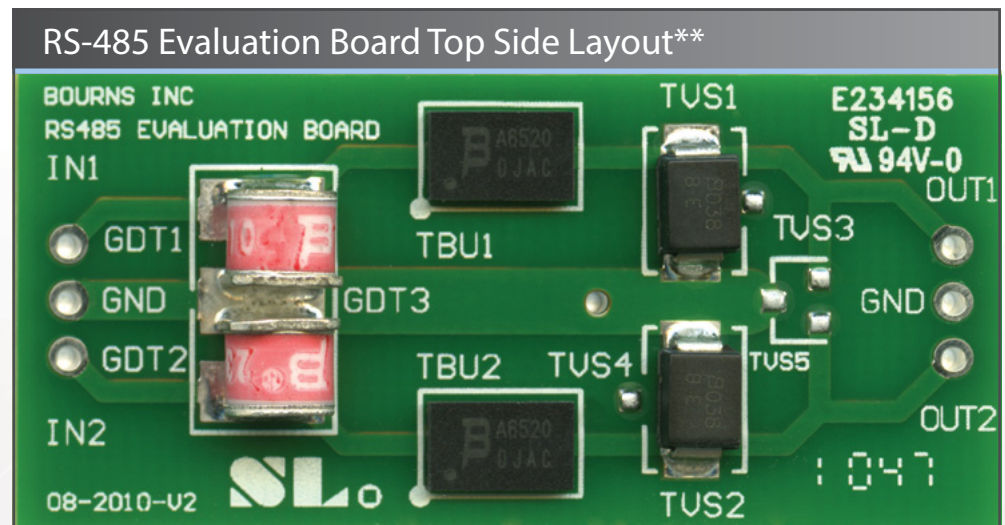
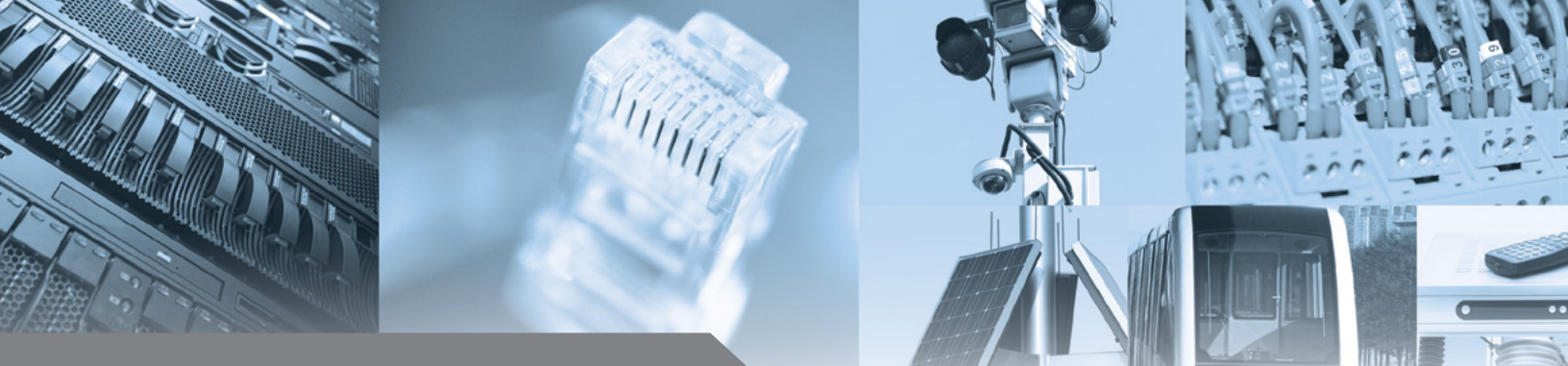

Figure 11 RS-485 Evaluation Board Schematic



Worldwide Sales Offices

Country/Region	Phone	Email
Americas:	+1-951-781-5500	americus@bourns.com
Brazil:	+55 11 5505 0601	americus@bourns.com
China:	+86 21 64821250	asiacus@bourns.com
Europe, Middle East, Africa:	+36 88 520 390	eurocus@bourns.com
Japan:	+81 49 269 3204	asiacus@bourns.com
Korea:	+82 70 4036 7730	asiacus@bourns.com
Singapore:	+65 6348 7227	asiacus@bourns.com
Taiwan:	+886 2 25624117	asiacus@bourns.com
Other Asia-Pacific Countries:	+886 2 25624117	asiacus@bourns.com

Technical Assistance Region	Phone	Email
Asia-Pacific:	+886 2 25624117	techweb@bourns.com
Europe, Middle East, Africa:	+36 88 885 877	eurotech@bourns.com
Americas:	+1-951-781-5500	techweb@bourns.com

BOURNS®

www.bourns.com

Bourns® products are available through an extensive network of manufacturer's representatives, agents and distributors. To obtain technical applications assistance, a quotation, or to place an order, contact a Bourns representative in your area.

Specifications subject to change without notice. Actual performance in specific customer applications may differ due to the influence of other variables. Customers should verify actual device performance in their specific applications.

"Bourns", "TBU" and "MSP" are registered trademarks of Bourns, Inc. in the U.S. and other countries. "IsoMOV" is a trademark of Bourns, Inc.
 COPYRIGHT © 2023, BOURNS, INC. • LITHO IN U.S.A. • MIMEO • 08/23 • e/GDT2330