



# Solving High Performance Circuit Protection Needs in Space-constrained, High Density Electronics

## WHITE PAPER

### NEED FOR GDT DESIGN INNOVATION

Smaller, more sensitive electronics applications are the result of continued demands for higher density and higher performance designs. While the features and capabilities of increasingly integrated applications have advanced substantially, these compact, and thus more sensitive designs, are now more susceptible to damage and unscheduled downtime from transient threats such as lightning and other high voltage surges.

And as equipment shrinks, the reality is that there is a finite amount of space on the printed circuit board (PCB). This means designers must constantly seek circuit solutions that provide the effective overvoltage protection they need to maintain the highest reliability, but this protection cannot be at the cost of valuable PCB space. To help OEMs overcome their shrinking application space challenges while still maintaining superior protection capabilities, Bourns engineers took an innovative approach to gas discharge tube (GDT) design.

This white paper will cover the basics of conventional GDT technology that include how its size and dimensions are critical to its handling of surge energy. Its overall size, however, many times is an obstacle in meeting smaller design requirements. It will then present a breakthrough design methodology to squeeze the GDT to significantly reduce the GDT's height, weight and overall volume. Also highlighted will be the various space-saving advantages designers can achieve with Bourns' new extremely compact GDT devices.

### CONVENTIONAL GAS DISCHARGE TUBE TECHNOLOGY

Gas Discharge Tube (GDT) devices have gained popularity as overvoltage protection devices due to their extremely low capacitance and low leakage characteristics, along with their high surge current handling capabilities. These characteristics make GDT devices ideal for use in a wide array of telecommunications, industrial and medical equipment designs requiring robust overvoltage protection.

A GDT device is an arrangement of electrodes and gas contained within a ceramic envelope.



2017-xx-A  
No Leads



2017-xx-SMH  
Horizontal Mount



2017-xx-SMC  
Vertical Mount



Figure 1. | 2-Electrode GDT

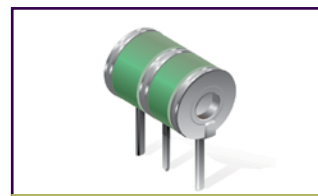

Figure 2. | 3-Electrode GDT



# Solving High Performance Circuit Protection Needs in Space-constrained, High Density Electronics

## CONVENTIONAL GAS DISCHARGE TUBE TECHNOLOGY *(Continued)*

GDT devices are typically placed in a circuit to limit voltage and to divert surge current to ground (common mode) or to a source (differential mode). The GDT device has very high impedance (>1 Gohm), so it is virtually invisible to the circuit during normal operation. When a voltage disturbance exceeds the GDT's sparkover value, the GDT will switch into a virtual short circuit, known as arc mode, diverting the surge current and protecting the equipment.



2017-xx-A  
No Leads



2017-xx-SMH  
Horizontal Mount



2017-xx-SMC  
Vertical Mount

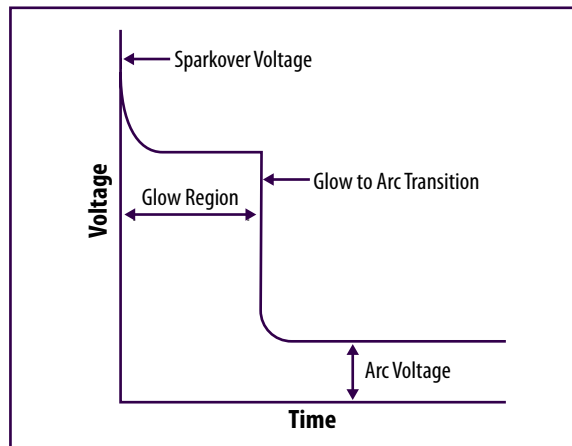

Figure 3. | General Operation of a GDT

The size of a conventional GDT device is defined by its overall diameter and length. These dimensions are critical to the GDT device's ability to handle surge energy as well as its ability to maintain electrical isolation. Figure 6 details the cross section of a typical GDT design that is considered state-of-the-art conventional technology today. The red arrow depicts the insulating pathway distance for creepage current. This distance is critical in providing a high level of electrical isolation to the GDT design. The diameter of the GDT and its thermal mass provide much of the current handling capabilities for the GDT.

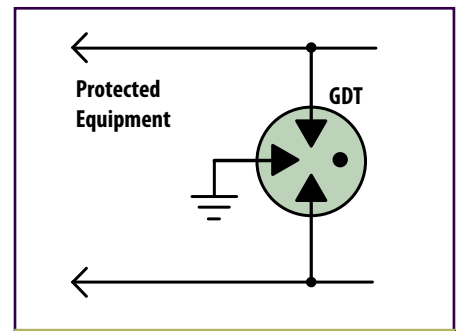

Figure 4. | Common Mode

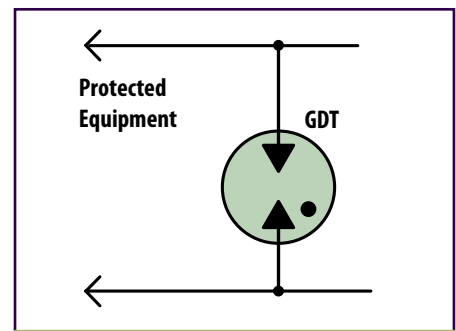

Figure 5. | Differential Mode

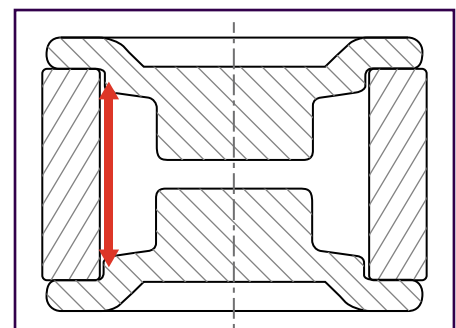

Figure 6. | Cross Section of a Typical GDT



# Solving High Performance Circuit Protection Needs in Space-constrained, High Density Electronics

## CONVENTIONAL GAS DISCHARGE TUBE TECHNOLOGY (Continued)

Table 1 below provides an overview of how size and surge current handling capabilities correlate.

	Size (diameter x length)	Typical 8/20 $\mu$ s rating *	Maximum 8/20 $\mu$ s rating *
	5 mm x 5 mm	3 kA	5 kA
	8 mm x 6 mm	10 kA	20 kA
	12 mm x 12 mm	40 kA	50 kA

Table 1. Overview of GDT Size and Current Handling Capabilities

\*As specified in ITU K.12 for 10 operations

Although conventional GDT devices provide robust overvoltage protection, they do so at the cost of valuable printed circuit board space.

## GDT DESIGNED WITH BOURNS® FLAT® TECHNOLOGY

Bourns has developed an innovative FLAT® GDT technology that effectively reduces the size of a GDT while maintaining its isolation and current handling capabilities. The cross section in figure 7 shows the insulating pathway in red.

The key design feature of Bourns® FLAT® GDT technology is the wrinkled creepage pathway that allows the GDT to be “squeezed” in the axial direction. When comparing the wrinkled pathway of a Bourns® FLAT® GDT to that of a similarly rated conventional GDT, the lengths would be similar. However, by squeezing the GDT into a Bourns® FLAT® technology configuration, the height, weight and overall volume is significantly reduced.

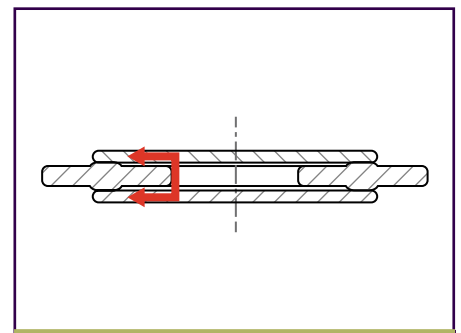

Figure 7. Cross Section of a FLAT® Technology GDT





## Solving High Performance Circuit Protection Needs in Space-constrained, High Density Electronics



2017-xx-A  
No Leads



2017-xx-SMH  
Horizontal Mount



2017-xx-SMC  
Vertical Mount

### THE FEATURES AND BENEFITS OF BOURNS® FLAT® GDT TECHNOLOGY

Bourns® FLAT® GDT technology provides the key features and benefits of conventional GDT technology in a volume and space saving design.

#### Features

- Compact, space saving design
- Robust surge current ratings
- Stable performance over life
- Low leakage and insertion loss
- Capacitance is constant regardless of voltage
- Low arc voltage
- Wide voltage range (90-600 V)
- Low oscillation design

#### Benefits

- Horizontal design provides a significant height savings versus Bourns' standard 5 mm GDTs
- Flexible mounting options including vertical and bottom side PCB
- Minimal impact on signal or system operation
- Voltage limiting performance suitable for sensitive equipment
- Long-term reliability and performance

Bourns® Model	ITU K.12 Class	8/20 $\mu$ s 10 operations	100 A 10/1000 $\mu$ s	10 A 10/1000 $\mu$ s	AC Life
2017 Series	III	10 kA	2.5 kA	>1500 operations	10 A <sub>rms</sub> , 1s, 10 operations

Table 2. | Key Performance Characteristics of Bourns® FLAT® GDT Series

### Space-Saving Advantage

When compared to a surface mount 8 mm Bourns® GDT, the horizontal mount Bourns® FLAT® Model 2017 GDT design is reduced in volume by an impressive 75 %, while maintaining the performance of the standard device.



Figure 8. | Horizontal Mount  
FLAT® GDT Design



Figure 9. | Bourns' standard  
8 mm GDT



# Solving High Performance Circuit Protection Needs in Space-constrained, High Density Electronics



2017-xx-A  
No Leads



2017-xx-SMH  
Horizontal Mount



2017-xx-SMC  
Vertical Mount

## THE FEATURES AND BENEFITS OF BOURNS® FLAT® GDT TECHNOLOGY

### Horizontal Mount

For designs with space constraints that can be solved by mounting on the bottom side of the PCB, the horizontally mounted Bourns® FLAT® GDT is also an ideal solution. With a 1.6 mm maximum height, this low profile design has minimal impact to the bottom side of the printed circuit board and minimizes space constraints.

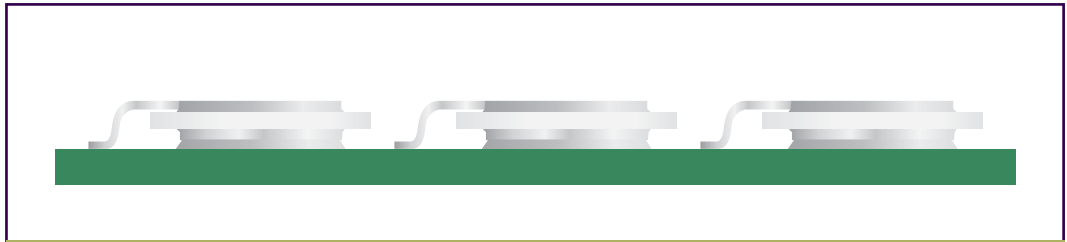

Figure 10. | Example of Horizontally Mounted Bourns® FLAT® GDTs

### Vertical Mount

The vertically mounted Bourns® FLAT® GDT design provides the most impressive space-saving option. This option typically allows for approximately twice\* the number of devices to be mounted in the same space as 8 mm surface mount Bourns® GDTs. This provides the ultimate solution for designers seeking to increase board density while providing robust overvoltage protection.

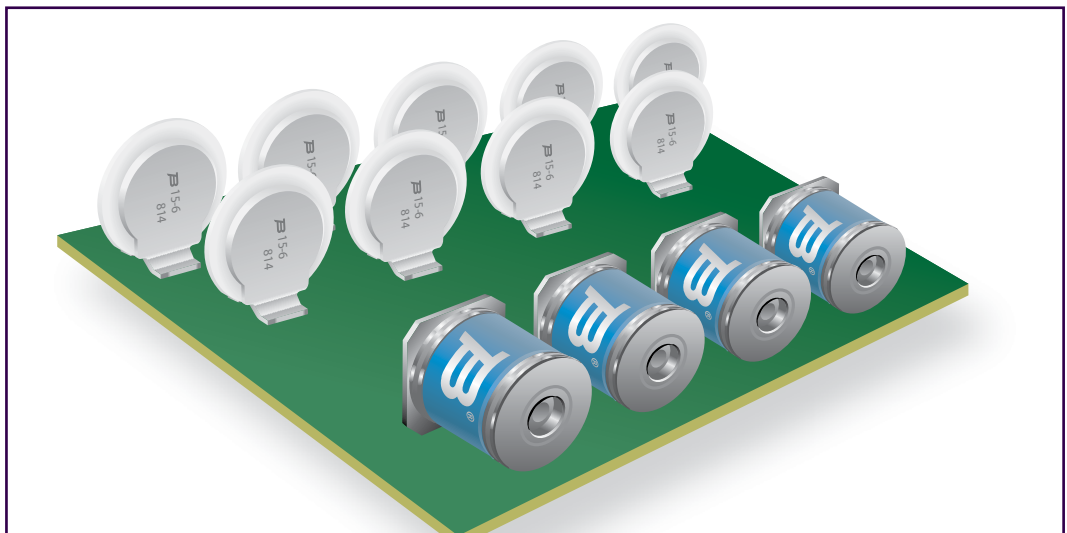

Figure 11. | Spatial Comparison of Bourns® FLAT® and Standard GDTs



## Solving High Performance Circuit Protection Needs in Space-constrained, High Density Electronics



2017-xx-A  
No Leads



2017-xx-SMH  
Horizontal Mount



2017-xx-SMC  
Vertical Mount

### MEETING SPACE-SAVING CIRCUIT PROTECTION NEEDS

Setting a new standard in volume and space-saving circuit protection design, Bourns® FLAT® GDTs effectively reduce the size by up to 75% while maintaining the overvoltage protection performance. Bourns has employed a breakthrough flat package and horizontal circuitry design to innovatively meet the more sensitive overvoltage protection requirements of high density and space-restricted applications such as telecommunications and industrial communications equipment, surge protective devices and PCB assemblies. Flexible mounting options provide electronic designers with solutions that can help reduce the size of their equipment designs or increase the density of existing designs while still providing an enhanced level of protection. For example, when vertically mounted, the Model 2017 Series is capable of supporting approximately twice the number of GDTs in the same board space as compared to similar board space using surface mount 8 mm Bourns® GDTs.

Bourns delivers the most comprehensive line of circuit protection technology and solutions in the industry. At R&D centers located worldwide, Bourns develops the full range of overvoltage and overcurrent protection technologies leveraging its many years of circuit protection engineering, design and support expertise. Bourns' global reputation for extensive application knowledge, quality products, innovative protection strategies and a wide range of technologies ensures the company can provide the right circuit protection solution for virtually any application need.

### ADDITIONAL RESOURCES

For more information about Bourns' complete line of circuit protection products, please visit:

[www.bourns.com](http://www.bourns.com)

COPYRIGHT © 2016 • BOURNS, INC. • 04/16 • e/GDT1610

"Bourns" and "FLAT" are registered trademarks of Bourns, Inc. in the U.S. and other countries.

**BOURNS®**

04/16 • e/GDT1610

**Americas:** Tel: +1-951 781-5500  
Email: [americus@bourns.com](mailto:americus@bourns.com)

**EMEA:** Tel: +36 88 520 390  
Email: [eurocus@bourns.com](mailto:eurocus@bourns.com)

**Asia-Pacific:** Tel: +886-2 256 241 17  
Email: [asiacus@bourns.com](mailto:asiacus@bourns.com)