



## Features

- Lead free as standard
- RoHS compliant\*
- ESD protection >25 kV
- Protects Vcc and two data lines

## Applications

- Ethernet - 10/100/1000 Base T
- Firewire and USB
- Portable electronics
- Video/graphic cards

# CD143A-SR05~12 – Steering/TVS Diode Array Series

## General Information

The CD143A-SR05 and CD143A-SR12 devices provides ESD, EFT and surge protection for the external ports of portable electronic devices such as cell phones, handheld electronics and personal computers.

The ESD protection provided by the component enables a data port to withstand a minimum  $\pm 8$  KV Contact /  $\pm 15$  KV Air Discharge per the ESD test method specified in IEC 61000-4-2. The device measures 2.80 mm x 1.20 mm and is available in a SOT-143 package intended to be mounted directly onto an FR4 printed circuit board.

The Bourns® device will meet IEC 61000-4-2 (ESD), IEC 61000-4-4 (EFT) and IEC 61000-4-5 (Surge) requirements.

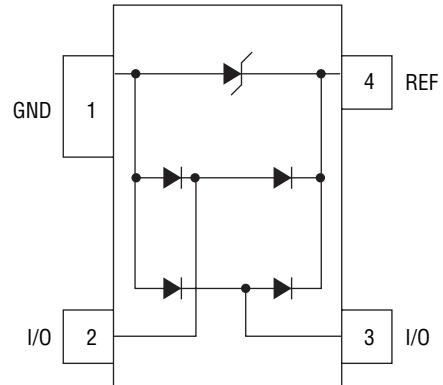

## Absolute Maximum Ratings, $T_A = 25^\circ\text{C}$ (Unless Otherwise Noted)

Parameter	Symbol	Value	Unit
Peak Pulse Power ( $t_p = 8/20 \mu\text{s}$ ) <sup>1</sup>	$P_{PP}$	500	W
Peak Pulse Current ( $t_p = 8/20 \mu\text{s}$ ) -SR05 -SR12	$I_{PP}$	30 16	A
Operating Temperature	$T_J$	-55 °C to 150 °C	°C
Storage Temperature	$T_{STG}$	-55 °C to 150 °C	°C
Peak Forward Voltage ( $I_f = 1 \text{ A } 8/20 \mu\text{s}$ )	$V_F$	1.5	V

## Electrical Characteristics, $T_A = 25^\circ\text{C}$ (Unless Otherwise Noted)

Parameter	Symbol	CD143A-SR05	CD143A-SR12	Unit
Breakdown Voltage Minimum @ 1 mA <sup>2</sup>	$V_{BR}$	6.0	13.3	V
Working Peak Voltage <sup>2</sup>	$V_{WM}$	5.0	12	V
Clamping Voltage Maximum @ $I_P = 1 \text{ A}$ <sup>2,3</sup>	$V_C$	9.8	19	V
Clamping Voltage Maximum @ $I_P$ <sup>2,3</sup>	$V_C$	20 @ 28 A	30 @ 16 A	V
Leakage Current @ $V_{WM}$ <sup>2</sup>	$I_D$	5.0	1.0	$\mu\text{A}$
Capacitance Maximum per Data Line @ 0 V, 1 MHz <sup>4,5</sup>	$C_J$	10	10	pF

Notes:

1. See Peak Pulse Power vs. Pulse Time.
2. From Pin 4 to Pin 1.
3. See Pulse Wave Form.
4. From Pin 1 to Pin 3, Pin 1 to Pin 2, Pin 3 to Pin 4, Pin 2 to Pin 4.
5. GND is connected to ground, REF is connected to  $+V_{CC}$  and input applies to  $V_{CC} = V_{WM}$ ,  $V_{OSC} = 30 \text{ mV}$ ,  $F = 1 \text{ MHz}$ .

# CD143A-SR05~12 – Steering/TVS Diode Array Series



## Product Dimensions

This is a molded JEDEC SOT-143 device. It weighs approximately 35 mg and has a flammability rating of UL 94V-0. The dimensions for the packaged device are shown below.

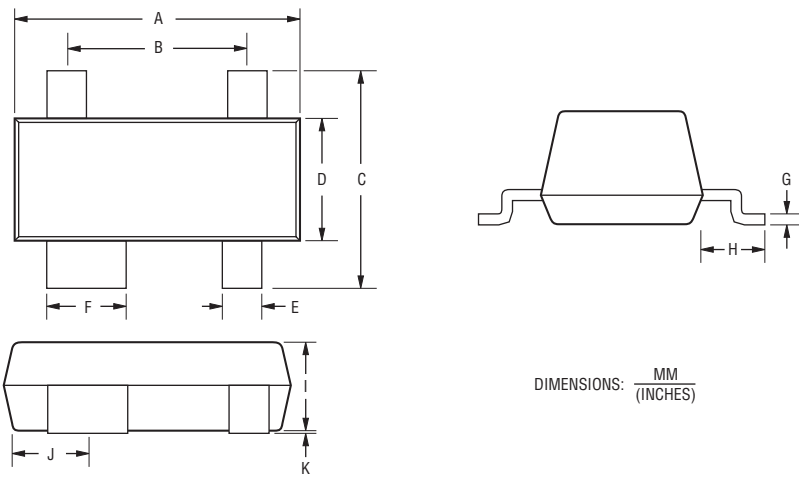

DIMENSIONS:  $\frac{\text{MM}}{\text{(INCHES)}}$

Dimensions	
A	$\frac{2.80 - 3.04}{(0.110 - 0.12)}$
B	$\frac{1.78 - 2.03}{(0.070 - 0.080)}$
C	$\frac{2.11 - 2.48}{(0.083 - 0.098)}$
D	$\frac{1.20 - 1.39}{(0.047 - 0.055)}$
E	$\frac{0.39 - 0.50}{(0.015 - 0.020)}$
F	$\frac{0.79 - 0.93}{(0.031 - 0.037)}$
G	$\frac{0.08 - 0.15}{(0.003 - 0.006)}$
H	$\frac{0.46 - 0.60}{(0.018 - 0.024)}$
I	$\frac{0.84 - 1.14}{(0.033 - 0.045)}$
J	$\frac{0.72 - 0.83}{(0.028 - 0.033)}$
K	$\frac{0.013 - 0.10}{(0.0005 - 0.004)}$

## Recommended Pad Layout

This is the footprint recommended for this SOT-143 device.

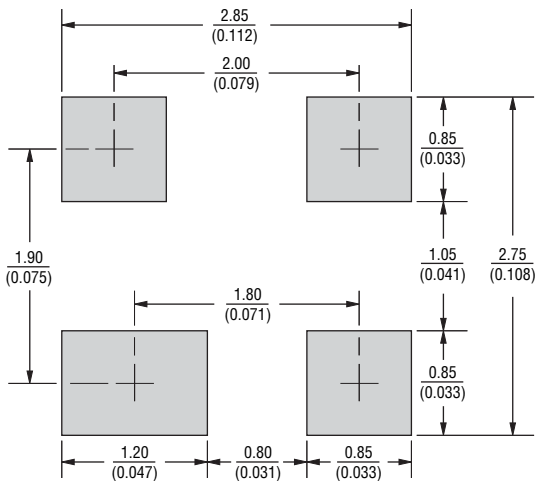

DIMENSIONS:  $\frac{\text{MM}}{\text{(INCHES)}}$

## Block Diagram

The device block diagram below includes the pin names and basic electrical connections associated with each channel.

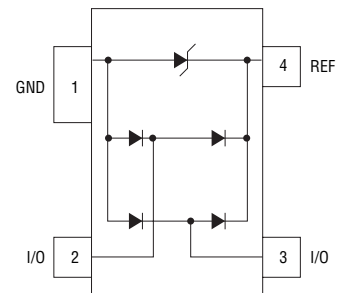

## Typical Part Marking

CD143A-SR05 .....5A  
 CD143A-SR12 .....12A

# CD143A-SR05~12 – Steering/TVS Diode Array Series



## Performance Graphs

### Peak Pulse Power vs Pulse Time

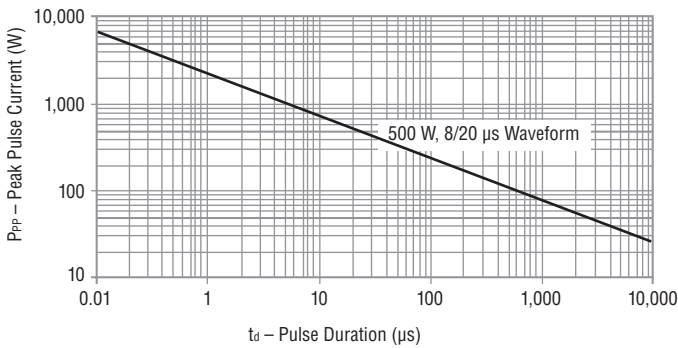

### Pulse Wave Form

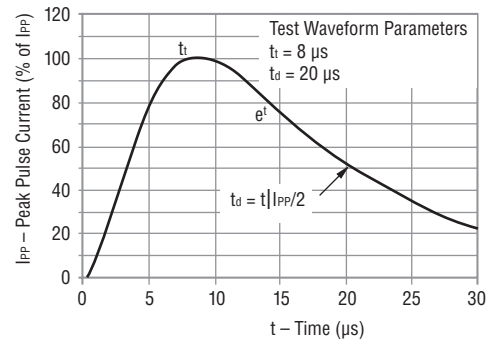

### Typical Capacitance vs. Reverse Voltage

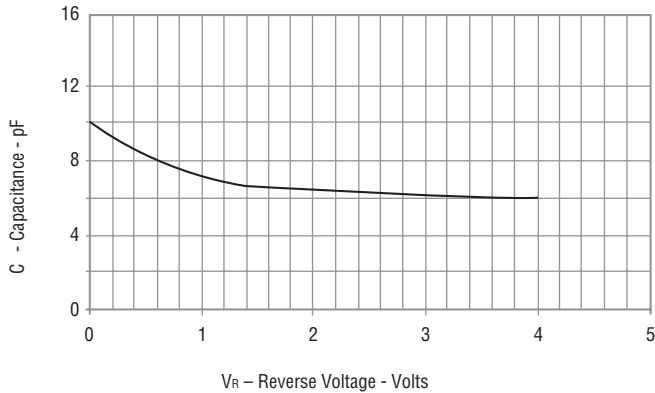

### Power Derating Curve

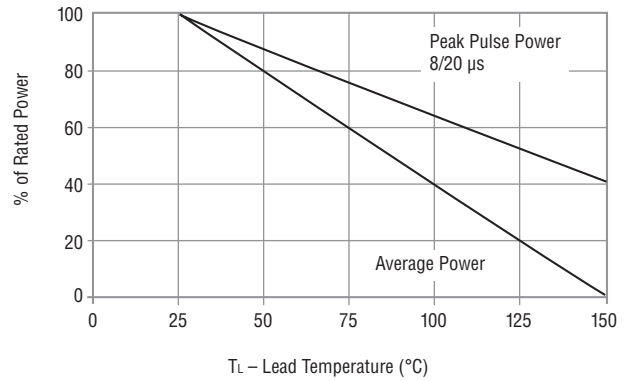

### How To Order

**CD 143A - SR 05**

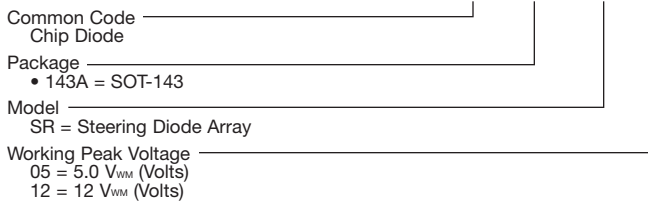

# CD143A-SR05~12 – Steering/TVS Diode Array Series

**BOURNS®**

## Packaging Information

The surface mount product is packaged in an 8 mm x 4 mm tape and reel format per EIA-481 standard.

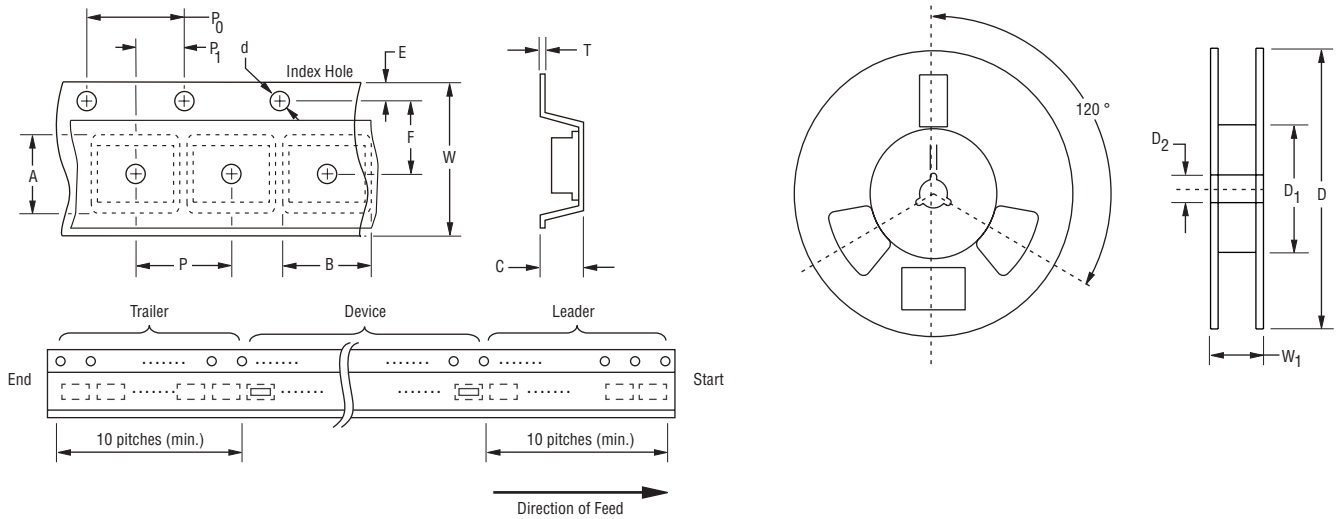

Item	Symbol	SOT-143
Carrier Width	A	$\frac{2.75 \pm 0.10}{(0.108 - 0.004)}$
Carrier Length	B	$\frac{3.30 \pm 0.10}{(0.130 - 0.004)}$
Carrier Depth	C	$\frac{1.25 \pm 0.10}{(0.049 - 0.004)}$
Sprocket Hole	d	$\frac{1.55 \pm 0.05}{(0.061 - 0.002)}$
Reel Outside Diameter	D	$\frac{178}{(7.008)}$
Reel Inner Diameter	D <sub>1</sub>	$\frac{50.0}{(1.969)}$ Min.
Feed Hole Diameter	D <sub>2</sub>	$\frac{13.0 \pm 0.20}{(0.512 - 0.008)}$
Sprocket Hole Position	E	$\frac{1.75 \pm 0.10}{(0.069 - 0.004)}$
Punch Hole Position	F	$\frac{3.50 \pm 0.05}{(0.138 - 0.002)}$
Punch Hole Pitch	P	$\frac{4.00 \pm 0.10}{(0.157 - 0.004)}$
Sprocket Hole Pitch	P <sub>0</sub>	$\frac{4.00 \pm 0.10}{(0.157 - 0.004)}$
Embossment Center	P <sub>1</sub>	$\frac{2.00 \pm 0.05}{(0.079 - 0.002)}$
Overall Tape Thickness	T	$\frac{0.20 \pm 0.10}{(0.008 - 0.004)}$
Tape Width	W	$\frac{8.00 \pm 0.20}{(0.315 - 0.008)}$
Reel Width	W <sub>1</sub>	$\frac{14.4}{(0.567)}$ Max.
Quantity per Reel	—	3,000



**Asia-Pacific:**  
Tel: +886-2 2562-4117 • Fax: +886-2 2562-4116  
**Europe:**  
Tel: +41-41 768 5555 • Fax: +41-41 768 5510  
**The Americas:**  
Tel: +1-951 781-5500 • Fax: +1-951 781-5700  
[www.bourns.com](http://www.bourns.com)