

*RoHS COMPLIANT

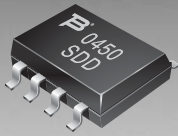

BOURNS®

Features

- Lead free device (RoHS compliant*)
- Protects up to 4 I/O ports
- Bidirectional configuration
- ESD protection
- Low capacitance 6 pF

Applications

- Ethernet – 10/100/1000 Base T
- Personal digital assistant
- Handheld electronics
- Cellular phones
- Video cards

CDNB50-SLVU2.8-8 – Low Capacitance TVS Array

General Information

The markets of portable communications, computing and video equipment are challenging the semiconductor industry to develop increasingly smaller electronic components.

Bourns offers Transient Voltage Suppressor Array combination diodes for surge and ESD protection applications in an 8 Lead Narrow Body SOIC package size format. Bourns Chip Diodes conform to JEDEC standards, are easy to handle on standard pick and place equipment and their flat configuration minimizes roll away.

The Bourns® device will meet IEC 61000-4-2 (ESD), IEC 61000-4-4 (EFT) and IEC 61000-4-5 (Surge) requirements.

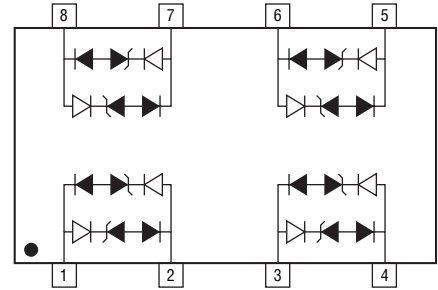

Electrical Characteristics (@ T_A = 25 °C Unless Otherwise Noted)

Parameter	Symbol	Min.	Nom.	Max.	Unit
Peak Pulse Current (t _p = 8/20 μs)	I _{PP}		30		A
Peak Pulse Power (t _p = 8/20 μs) ¹	P _{PP}		600		W
Working Voltage	V _{WM}			2.8	V
Breakdown Voltage @ 1 mA	V _{BR}	3.0			V
Leakage Current @ V _{WM}	I _D			1.0	μA
Capacitance @ 0 V, 1 MHz	C		6		pF
Snapback Voltage		2.8			V
Clamping Voltage	@ I _{PP} = 2 A	V _C		5.5	V
	@ I _{PP} = 5 A	V _C		8.5	V
	@ I _{PP} = 24 A	V _C		15	V
	@ I _{PP} = 30 A	V _C		17	V

Note:

1. See Peak Pulse Power vs. Pulse Time.

Thermal Characteristics (@ T_A = 25 °C Unless Otherwise Noted)

Parameter	Symbol	Min.	Nom.	Max.	Unit
Operating Temperature	T _J	-55	+25	+150	°C
Storage Temperature	T _{STG}	-55	+25	+150	°C

CDNBS08-SLVU2.8-8 – Low Capacitance TVS Array



Mechanical Characteristics

This is a molded JEDEC Narrow Body SO-8 package with lead free 100 % Sn plating on the lead frame. It weighs approximately 15 mg and has a flammability rating of UL 94V-0.

Product Dimensions

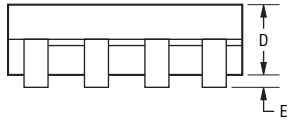
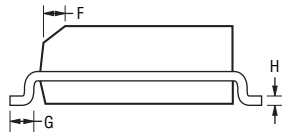
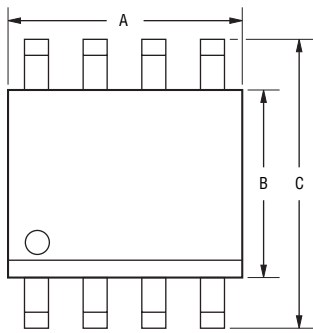

DIMENSIONS = $\frac{\text{MILLIMETERS}}{\text{(INCHES)}}$

Dimensions	
A	$\frac{4.80 - 5.00}{(0.189 - 0.196)}$
B	$\frac{3.80 - 4.00}{(0.150 - 0.157)}$
C	$\frac{5.80 - 6.20}{(0.229 - 0.244)}$
D	$\frac{1.35 - 1.75}{(0.054 - 0.068)}$
E	$\frac{0.10 - 0.25}{(0.004 - 0.008)}$
F	$\frac{0.25 - 0.50}{(0.010 - 0.019)}$
G	$\frac{0.40 - 1.250}{(0.016 - 0.049)}$
H	$\frac{0.18 - 0.25}{(0.007 - 0.009)}$

Recommended Footprint

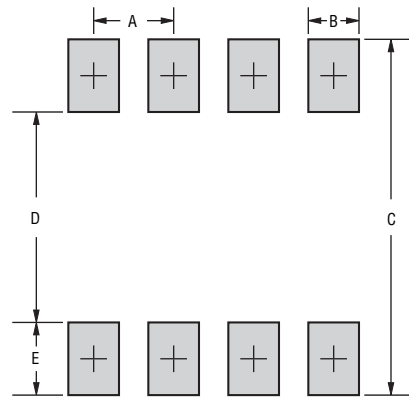

Dimensions	
A	$\frac{1.143 - 1.397}{(0.045 - 0.055)}$
B	$\frac{0.635 - 0.889}{(0.025 - 0.035)}$
C	$\frac{6.223}{(0.245)} \text{ Min.}$
D	$\frac{3.937 - 4.191}{(0.155 - 0.165)}$
E	$\frac{1.016 - 1.27}{(0.040 - 0.050)}$

How To Order

Common Code _____ **CD NBS08 - SLVU 2.8 - 8**

CD = Chip Diode

Package _____

NBS08 = Narrow Body SOIC8 Package

Model _____

SLVU = Low Capacitance TVS Array

Working Peak Reverse Voltage _____

2.8 = 2.8 V_{RWM} (Volts)

Number of Diodes _____

Typical Part Marking

CDNBS08-SLVU2.8-8 **SL8**

CDNBS08-SLVU2.8-8 – Low Capacitance TVS Array

BOURNS®

Block Diagram

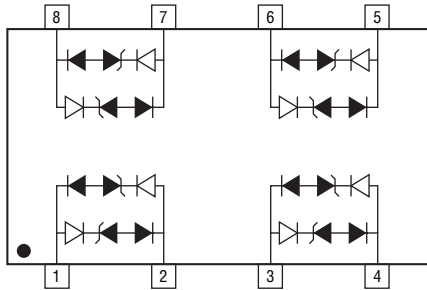

Device Pinout

Pin	Bidirectional Common Mode	Bidirectional Differential Mode
1	Line 1	Line Pair 1
2	GND	Line Pair 1
3	GND	Line Pair 2
4	Line 4	Line Pair 2
5	Line 3	Line Pair 4
6	GND	Line Pair 4
7	GND	Line Pair 3
8	Line 2	Line Pair 3

Performance Graphs

Peak Pulse Power vs Pulse Time

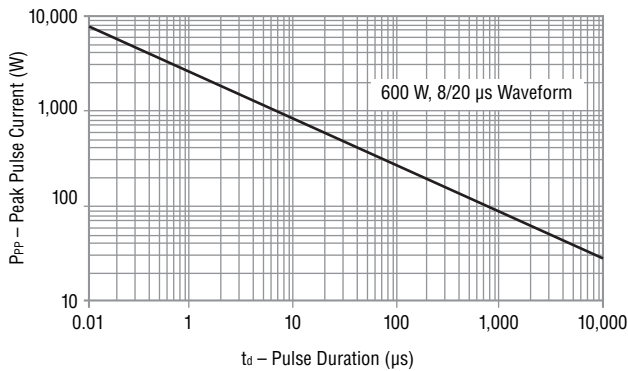

Pulse Wave Form

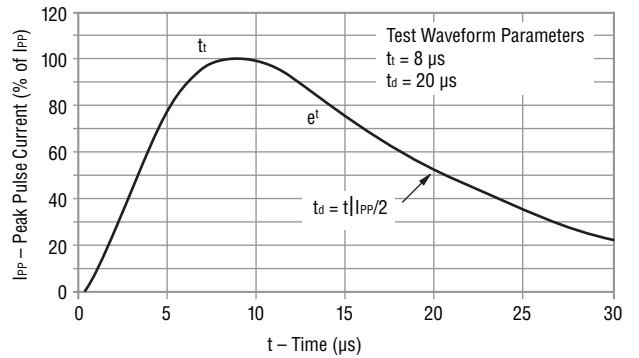

Power Derating Curve

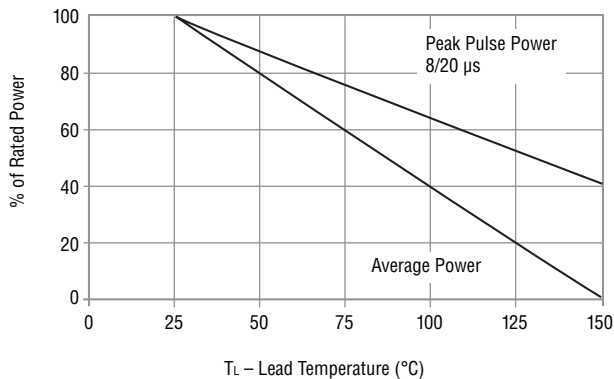

Specifications are subject to change without notice.
 Customers should verify actual device performance in their specific applications.

CDNBS08-SLVU2.8-8 – Low Capacitance TVS Array

BOURNS®

Packaging Specifications

The product will be dispensed in Tape and Reel format (see diagram below).

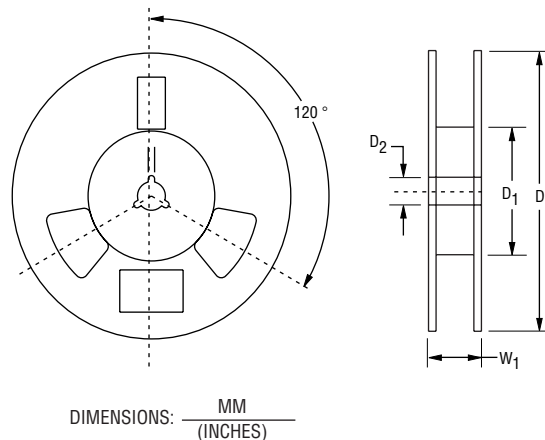
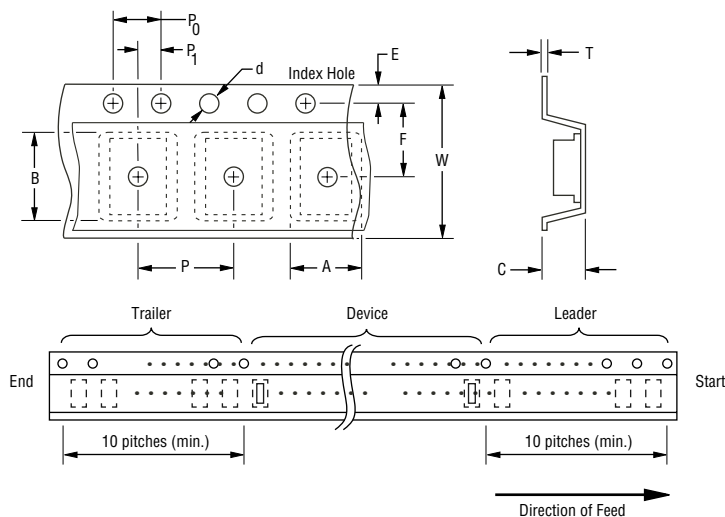

Devices are packed in accordance with EIA standard RS-481-A.

Item	Symbol	NSOIC 8L
Carrier Width	A	$\frac{6.7 \pm 0.10}{(0.264 \pm 0.004)}$
Carrier Length	B	$\frac{5.5 \pm 0.10}{0.217 \pm 0.004}$
Carrier Depth	C	$\frac{2.10 \pm 0.10}{0.083 \pm 0.004}$
Sprocket Hole	d	$\frac{1.55 \pm 0.05}{(0.061 \pm 0.002)}$
Reel Outside Diameter	D	$\frac{330}{(12.992)}$
Reel Inner Diameter	D ₁	$\frac{80.0}{(3.1500)}$ MIN.
Feed Hole Diameter	D ₂	$\frac{13.0 \pm 0.20}{(0.512 \pm 0.008)}$
Sprocket Hole Position	E	$\frac{1.75 \pm 0.10}{(0.069 \pm 0.004)}$
Punch Hole Position	F	$\frac{3.50 \pm 0.05}{(0.138 \pm 0.002)}$
Punch Hole Pitch	P	$\frac{8.00 \pm 0.10}{(0.315 \pm 0.004)}$
Sprocket Hole Pitch	P ₀	$\frac{4.00 \pm 0.10}{(0.157 \pm 0.004)}$
Embossment Center	P ₁	$\frac{2.00 \pm 0.05}{(0.079 \pm 0.002)}$
Overall Tape Thickness	T	$\frac{0.20 \pm 0.10}{(0.008 \pm 0.004)}$
Tape Width	W	$\frac{12.00 \pm 0.20}{(0.472 \pm 0.008)}$
Reel Width	W ₁	$\frac{18.4}{(0.724)}$ MAX.
Quantity per Reel	-	2500



Asia-Pacific:
Tel: +886-2 2562-4117 • Fax: +886-2 2562-4116
Europe:
Tel: +41-41 768 5555 • Fax: +41-41 768 5510
The Americas:
Tel: +1-951 781-5500 • Fax: +1-951 781-5700
www.bourns.com

REV. 09/09

Specifications are subject to change without notice.
Customers should verify actual device performance in their specific applications.