

Features

- RoHS compliant*
- Low capacitance - 0.55 pF
- ESD protection >15 kV
- Protects 4 I/O and 1 V_{DD} line

Applications

- HDMI 1.4
- Digital Visual Interface (DVI)
- USB 3.0 / USB OTG
- Memory protection
- SIM card ports

CDSOT236-0504LC - TVS/Steering Diode Array

General Information

The CDSOT236-0504LC device provides ESD, EFT and Surge protection for high speed data ports meeting IEC 61000-4-2 (ESD), IEC 61000-4-4 (EFT) and IEC 61000-4-5 (Surge) requirements. The Transient Voltage Suppressor array offers a Working Peak Reverse Voltage of 5 V and Minimum Breakdown Voltage of 6 V.

The SOT23-6L packaged device will mount directly onto the industry standard SOT23-6L footprint. Bourns® Chip Diodes are easy to handle with standard pick and place equipment and the flat configuration minimizes roll away.

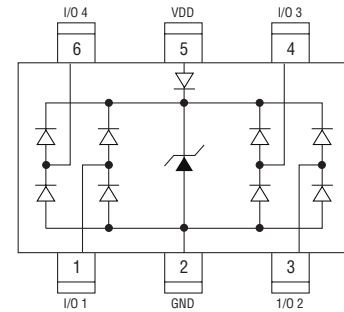

Thermal Characteristics (@ T_A = 25 °C Unless Otherwise Noted)

Parameter	Symbol	CDSOT236-0504LC	Unit
Peak Pulse Current (t _p = 8/20 μs)	I _{PP}	4.7	A
Storage Temperature	T _{STG}	-55 to +150	°C
Operating Temperature	T _{OPR}	-55 to +85	°C
Operating Supply Voltage	V _{DC}	6	V
ESD per IEC 61000-4-2 (Air) (I/O Pins)	V _{ESD_IO}	19	kV
ESD per IEC 61000-4-2 (Contact) (I/O Pins)		12	
ESD per IEC 61000-4-2 (Air) (V _{CC} to GND)	V _{ESD_VCC}	30	kV
ESD per IEC 61000-4-2 (Contact) (V _{CC} to GND)		30	
DC Voltage at any I/O Pin	V _{IO}	(GND-0.5) to (V _{CC} +0.5)	V

Electrical Characteristics (@ T_A = 25 °C Unless Otherwise Noted)

Parameter	Symbol	CDSOT236-0504LC	Unit
Maximum Reverse Standoff Voltage ¹	V _{RWM}	5.0	V
Maximum Leakage Current ¹ @ V _{RWM}	I _L	5.0	μA
Maximum Channel Leakage Current @ V _{RWM}	I _{CD}	1.0	μA
Minimum Reverse Breakdown Voltage ¹ @ I _{BV} = 1 mA	V _{BR}	6.0	V
Maximum Forward Voltage ⁴ @ I _F = 15 mA	V _F	1.0	V
Typical Clamping Voltage ²	V _C	8.1	V
Typical ESD Clamping Voltage - I/O ²	V _{clamp_io}	12	V
Typical ESD Clamping Voltage - V _{CC} ¹	V _{clamp_VCC}	9.0	V
Maximum Channel Input Capacitance ² @ V _{PIN5} = 5 V, V _{PIN2} = 0 V, V _{IN} = 2.5 V, f = 1 MHz	C _{IN}	0.65	pF
Maximum Channel to Channel Input Capacitance ³ @ V _{PIN5} = 5 V, V _{PIN2} = 0 V, V _{IN} = 2.5 V, f = 1 MHz	C _{CROSS}	0.06	pF
Maximum Variation of Channel Input Capacitance @ V _{PIN5} = 5 V, V _{PIN2} = 0 V, V _{IN} = 2.5 V, f = 1 MHz (I/O Pin to GND)	ΔC _{IN}	0.06	pF

NOTES:

1. Pin 5 to Pin 2 (GND)
2. Pin 1,3,4 or 6 to Pin 2 (GND)
3. Between any two of Pins 1,3,4,6
4. Pin 2 (GND) to Pin 5

*RoHS Directive 2002/95/EC Jan 27 2003 including Annex.
Specifications are subject to change without notice.

Customers should verify actual device performance in their specific applications.

CDSOT236-0504LC - TVS/Steering Diode Array

BOURNS®

Product Dimensions

This is a molded SOT23-6L package with lead free 100 % Matte Sn on the lead frame. It weighs approximately 3 mg and has a flammability rating of UL 94V-0.

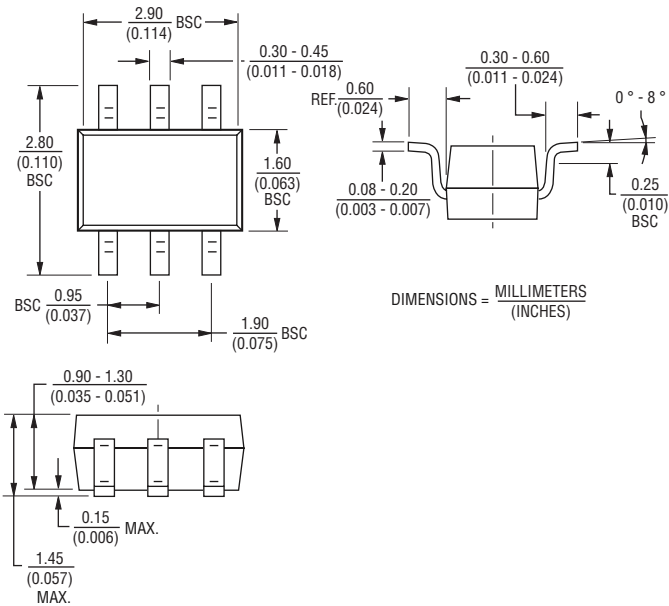

Circuit Diagram

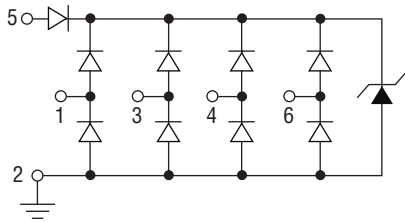

Recommended Footprint

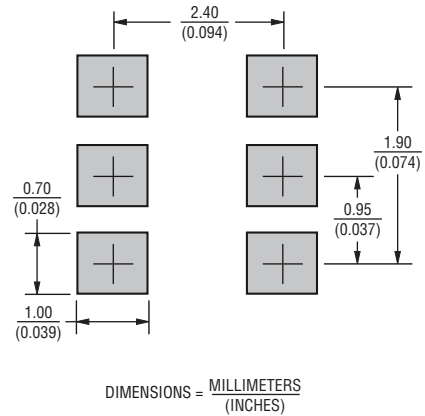

Typical Part Marking

CDSOT236-0504LC54L

How to Order

CD SOT236 - 05 04 LC

- Common Diode _____
- Chip Diode _____
- Package _____
SOT236 = SOT23-6L Package
- Working Peak Reverse Voltage _____
05 = 5 V_{RWM} (Volts)
- Number of Lines _____
04 = 4 Data Lines
- Suffix _____
LC = Low Capacitance

Typical Characteristics

Typical Variation of C_{IN} vs. V_{IN}

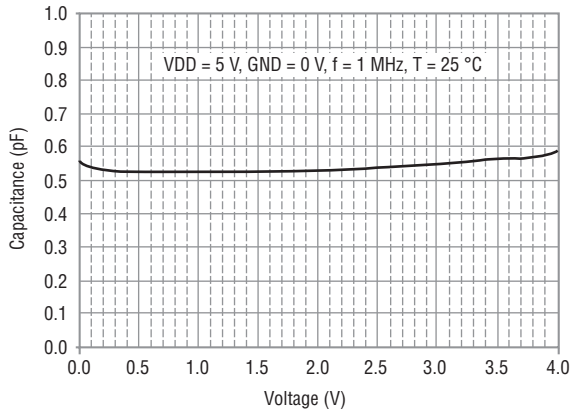

Typical Variation of C_{IN} vs. V_{IN}

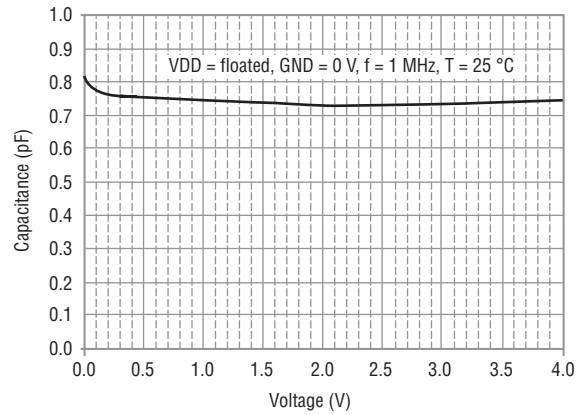

Typical Variation of C_{IO} to IO vs. V_{IN}

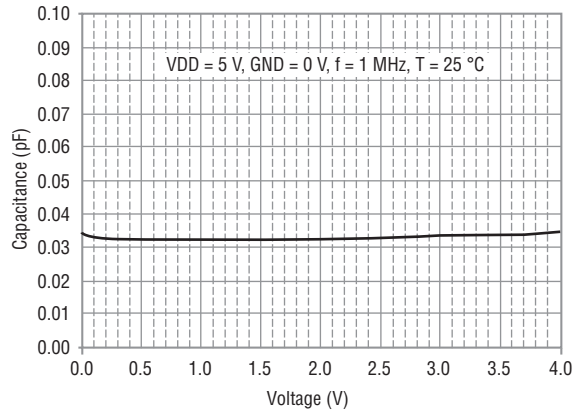

Typical Variation of C_{IO} to IO vs. V_{IN}

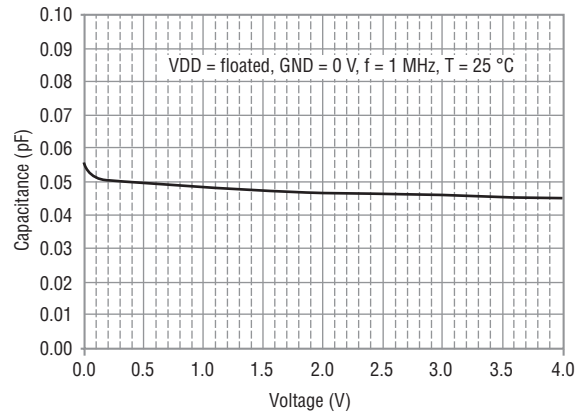

Insertion Loss S21 (I/O to GND)

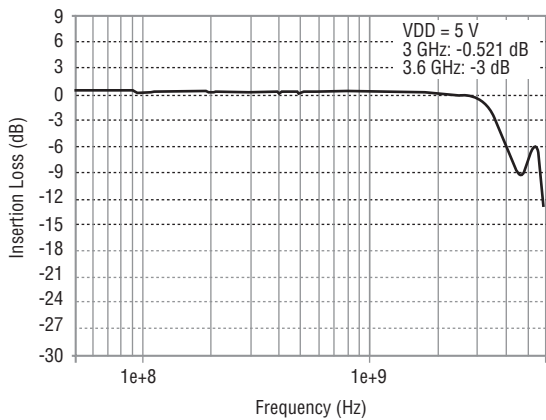

Insertion Loss S21 (I/O to GND)

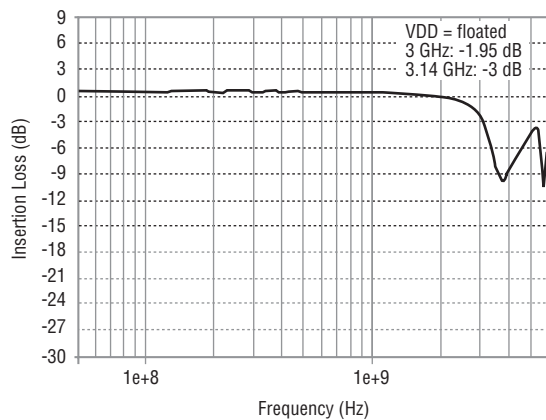

CDSOT236-0504LC - TVS/Steering Diode Array

BOURNS®

Packaging Information

The product will be dispensed in tape and reel format (see diagram below)

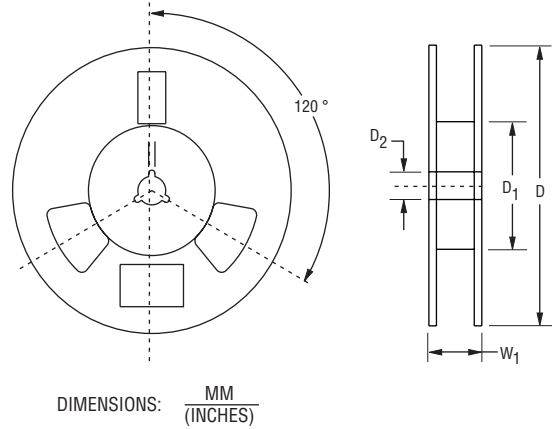
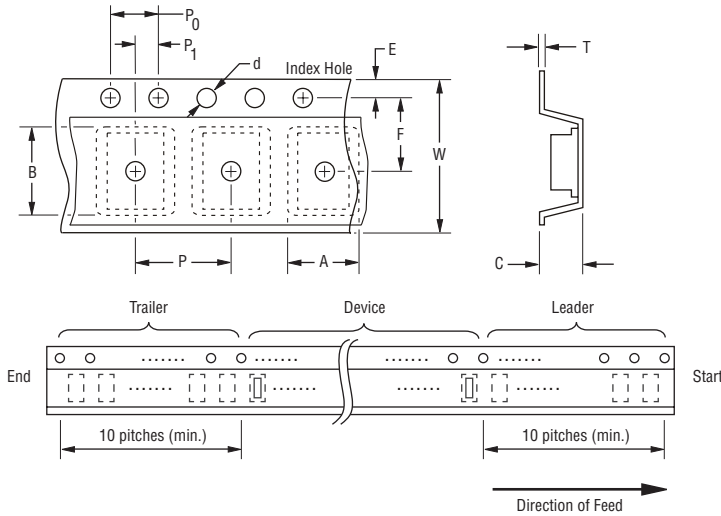

Devices are packed in accordance with EIA standard RS-481-A.

Item	Symbol	SOT23-6L
Carrier Width	A	$\frac{3.90 \pm 0.10}{(0.154 \pm 0.004)}$
Carrier Length	B	$\frac{3.90 \pm 0.10}{(0.154 \pm 0.004)}$
Carrier Depth	C	$\frac{0.90 \pm 0.10}{(0.035 \pm 0.004)}$
Sprocket Hole	d	$\frac{1.55 \pm 0.05}{(0.061 \pm 0.002)}$
Reel Outside Diameter	D	$\frac{178}{(7.008)}$
Reel Inner Diameter	D ₁	$\frac{50.0}{(1.969)}$ MIN.
Feed Hole Diameter	D ₂	$\frac{13.0 \pm 0.20}{(0.512 \pm 0.008)}$
Sprocket Hole Position	E	$\frac{1.75 \pm 0.10}{(0.069 \pm 0.004)}$
Punch Hole Position	F	$\frac{3.50 \pm 0.05}{(0.138 \pm 0.002)}$
Punch Hole Pitch	P	$\frac{4.00 \pm 0.10}{(0.157 \pm 0.004)}$
Sprocket Hole Pitch	P ₀	$\frac{4.00 \pm 0.10}{(0.157 \pm 0.004)}$
Embossment Center	P ₁	$\frac{2.00 \pm 0.05}{(0.079 \pm 0.002)}$
Overall Tape Thickness	T	$\frac{0.20 \pm 0.10}{(0.008 \pm 0.004)}$
Tape Width	W	$\frac{8.00 \pm 0.20}{(0.315 \pm 0.008)}$
Reel Width	W ₁	$\frac{14.4}{(0.567)}$ MAX.
Quantity per Reel	--	3000



Asia-Pacific:

Tel: +886-2 2562-4117 • Fax: +886-2 2562-4116

Europe:

Tel: +41-41 768 5555 • Fax: +41-41 768 5510

The Americas:

Tel: +1-951 781-5500 • Fax: +1-951 781-5700

www.bourns.com

REV. 11/09

Specifications are subject to change without notice.
Customers should verify actual device performance in their specific applications.