

Product Change Notification

PRECISION POTENTIOMETERS

May 24, 2012 -
REVISED JANUARY 23, 2013



Bourns Sensors & Controls Product Line - Model 6639 Product Enhancements

In line with our commitment to product excellence and continuous improvement, Bourns Sensors & Controls Product Line is pleased to introduce design enhancements to our [Model 6639 Single-Turn Precision Potentiometer](#).

The design enhancements include the addition of a C-ring to help prevent damage that may be induced by excessive axial force applied to the shaft when installing gears or other mechanical devices, and the addition of an internal shoulder to the shaft to better resist shaft pull out from the body if excessive shaft pull force is applied.

Bourns first advised of this change in [May, 2012](#) but the implementation of the design enhancements listed above was delayed as we are also including a process enhancement change to the attachment of the contact spring to the rotor. The current process for attachment of the contact spring to the rotor is a three-point heat stake design. This process will change to a five-point heat stake design for more accurate positioning of the contact spring.

Please refer to the shaft/bushing design illustrations below:

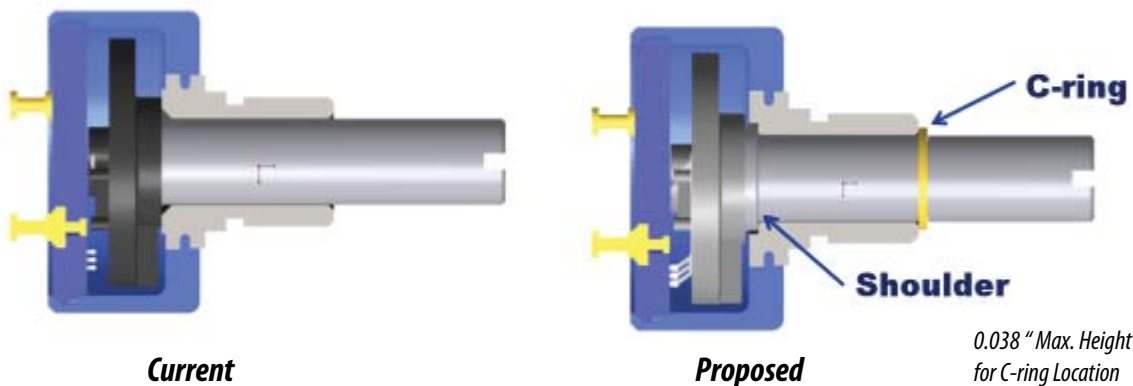

Externally, the design enhancements will be recognized by the C-ring that is visible in front of the bushing. The noted enhancements to this product family will have no effect on form or function. Both the new internal shoulder and five-point heat stake of the contact spring will help increase the robustness and reliability of the part. These design enhancements allow the potentiometer to withstand higher axial loads typically encountered on installation or removal of mechanical devices from the shaft. All performance specifications listed on the current data sheet will remain unchanged.

Revised implementation dates are as follows:

*Last time buy date: **February 24, 2013***

*First date code using the above changes: **1314M***

*Deliveries of modified product will begin: **April, 2013***

Qualification data for the new material was completed in December, 2012 and is available upon request.

Sample products containing the enhancements will be available April 1, 2013. Please contact Customer Service and request an MEWRX-BSCI for a sample order.

Should you have any questions or need additional information, please contact [Customer Service/Inside Sales](#).