

QUAD FORWARD-CONDUCTING BUFFERED P-GATE THYRISTORS



TISP6NTP2B Programmable Protector

- Overvoltage Protection for ISDN DC Feeds:**
- Supply Voltages Down to -120 V
 - Low 5 mA max. Gate Triggering Current
 - High 150 mA min. (25 °C) Holding Current

Rated for Common Impulse Waveforms

Voltage Impulse Form	Current Impulse Shape	I _{TSP} A
10/1000 μs	10/1000 μs	20
10/700 μs	5/310 μs	25
1.2/50 μs	8/20 μs	60
2/10 μs	2/10 μs	70

 UL Recognized Component

Description

The TISP6NTP2B has an array of four buffered P-gate forward conducting thyristors with twin commoned gates and a common anode connection. Each thyristor cathode has a separate terminal connection. An antiparallel anode-cathode diode is connected across each thyristor. The buffer transistors reduce the gate supply current.

In use, the cathodes of an TISP6NTP2B thyristors are connected to the four conductors to be protected (see Figure 2 and Figure 3). Each gate is connected to the appropriate negative voltage feed. The anode of the TISP6NTP2B is connected to the system common. The TISP6NTP2B is in an 8-pin small-outline surface mount package.

Positive overvoltages are clipped to common by forward conduction of the TISP6NTP2B antiparallel diode. In Figure 2, a negative overvoltage draws a current through the 6.8 Ω resistor and the voltage developed triggers the thyristor on. In Figure 3, negative overvoltages are initially clipped close to the negative supply by emitter follower action of the TISP6NTP2B buffer transistor. If sufficient clipping current flows, the TISP6NTP2B thyristor will regenerate and switch into a low voltage on-state condition. As the negative overvoltage subsides, the high holding current of the TISP6NTP2B prevents d.c. latchup.

D Package (Top View)

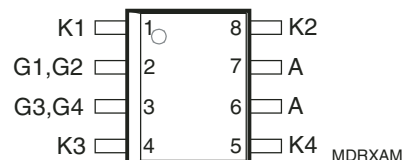

Device Symbol

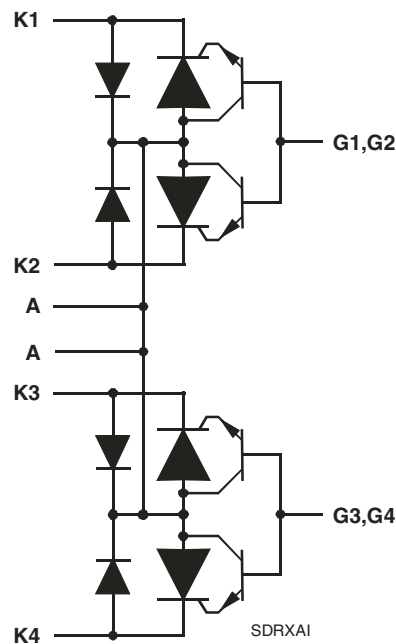

How To Order

Device	Package	Carrier	For Standard Termination Finish Order As	For Lead Free Termination Finish Order As
TISP6NTP2B	D, Small-Outline	Tape and Reel	TISP6NTP2BDR	TISP6NTP2BDR-S
		Tube	TISP6NTP2BD	TISP6NTP2BD-S

*RoHS Directive 2002/95/EC Jan 27 2003 including Annex JUNE 1998 - REVISED FEBRUARY 2005
 Specifications are subject to change without notice.
 Customers should verify actual device performance in their specific applications.

TISP6NTP2B Programmable Protector

BOURNS®

Absolute Maximum Ratings, $T_A = 25\text{ }^\circ\text{C}$ (Unless Otherwise Noted)

Rating	Symbol	Value	Unit
Repetitive peak off-state voltage, $I_G = 0$	V_{DRM}	-130	V
Repetitive peak gate-cathode voltage, $V_{KA} = 0$	V_{GKRM}	-120	V
Non-repetitive peak on-state pulse current, (see Notes 1 and 2) 10/1000 μs (Bellcore GR-1089-CORE, Issue 1, November 1994, Section 4) 0.2/310 μs (I3124, open-circuit voltage wave shape 0.5/700 μs) 5/310 μs (ITU-T K.20 & K.21, open-circuit voltage wave shape 10/700 μs) 8/20 μs (IEC 61000-4-5:1995, open-circuit voltage wave shape 1.2/50 μs) 2/10 μs (Bellcore GR-1089-CORE, Issue 1, November 1994, Section 4)	I_{TSP}	20 25 25 60 70	A
Non-repetitive peak on-state current, 50/60 Hz, (see Notes 1 and 2) 100 ms 1 s 5 s 300 s 900 s	I_{TSM}	7 2.7 1.5 0.45 0.43	A
Non-repetitive peak gate current, 1/2 μs pulse, cathodes commoned (see Note 1)	I_{GSM}	25	A
Operating free-air temperature range	T_A	-40 to +85	$^\circ\text{C}$
Junction temperature	T_J	-40 to +150	$^\circ\text{C}$
Storage temperature range	T_{stg}	-65 to +150	$^\circ\text{C}$

- NOTES: 1. Initially the protector must be in thermal equilibrium. The surge may be repeated after the device returns to its initial conditions.
2. These non-repetitive rated currents are peak values for either polarity. The rated current values may be applied to any cathode-anode terminal pair. Additionally, all cathode-anode terminal pairs may have their rated current values applied simultaneously (in this case the anode terminal current will be four times the rated current value of an individual terminal pair).

Recommended Operating Conditions

	Min.	Typ.	Max.	Unit
R1, R2 Series resistor for ITU-T recommendation K.20	12			Ω
Series resistor for ITU-T recommendation K.21	20			

Electrical Characteristics for any Section, $T_A = 25\text{ }^\circ\text{C}$ (Unless Otherwise Noted)

Parameter	Test Conditions	Min.	Typ.	Max.	Unit
I_D Off-state current	$V_D = V_{DRM}$, $I_G = 0$	$T_J = 25\text{ }^\circ\text{C}$		-5	μA
		$T_J = 85\text{ }^\circ\text{C}$		-50	μA
V_F Forward voltage	$I_F = 0.6\text{ A}$, $t_W = 500\text{ }\mu\text{s}$, $V_{GG} = -50\text{ V}$ $I_F = 18\text{ A}$, $t_W = 500\text{ }\mu\text{s}$, $V_{GG} = -50\text{ V}$			3 5	V
I_H Holding current	$I_T = -1\text{ A}$, $di/dt = 1\text{ A/ms}$, $V_{GG} = -50\text{ V}$, $T_J = 85\text{ }^\circ\text{C}$	-150			mA
I_{GKS} Gate reverse current	$V_{GG} = V_{GKRM}$, $V_{AK} = 0$	$T_J = 25\text{ }^\circ\text{C}$		-5	μA
		$T_J = 85\text{ }^\circ\text{C}$		-50	μA
I_{GAT} Gate reverse current, on state	$I_T = -0.6\text{ A}$, $t_W = 500\text{ }\mu\text{s}$, $V_{GG} = -50\text{ V}$			-1	mA
I_{GAF} Gate reverse current, forward conducting state	$I_F = 0.6\text{ A}$, $t_W = 500\text{ }\mu\text{s}$, $V_{GG} = -50\text{ V}$			-40	mA
I_{GT} Gate trigger current	$I_T = -5\text{ A}$, $t_{p(g)} \geq 20\text{ }\mu\text{s}$, $V_{GG} = -50\text{ V}$			5	mA
V_{GT} Gate trigger voltage	$I_T = -5\text{ A}$, $t_{p(g)} \geq 20\text{ }\mu\text{s}$, $V_{GG} = -50\text{ V}$			2.5	V

TISP6NTP2B Programmable Protector

BOURNS®

Electrical Characteristics for any Section, $T_A = 25\text{ }^\circ\text{C}$ (Unless Otherwise Noted) (continued)

Parameter	Test Conditions	Min.	Typ.	Max.	Unit
C_{AK} Anode-cathode off-state capacitance	$f = 1\text{ MHz}$, $V_d = 1\text{ V}$, $I_G = 0$, (see Note 3)	$V_D = -3\text{ V}$		100	pF
		$V_D = -50\text{ V}$		60	pF

NOTE 3: These capacitance measurements employ a three terminal capacitance bridge incorporating a guard circuit. The unmeasured device terminals are a.c. connected to the guard terminal of the bridge.

Thermal Characteristics

Parameter	Test Conditions	Min.	Typ.	Max.	Unit
$R_{\theta JA}$ Junction to free air thermal resistance	$P_{tot} = 0.52\text{ W}$, $T_A = 85\text{ }^\circ\text{C}$, 5 cm^2 , FR4 PCB			160	$^\circ\text{C/W}$

Parameter Measurement Information

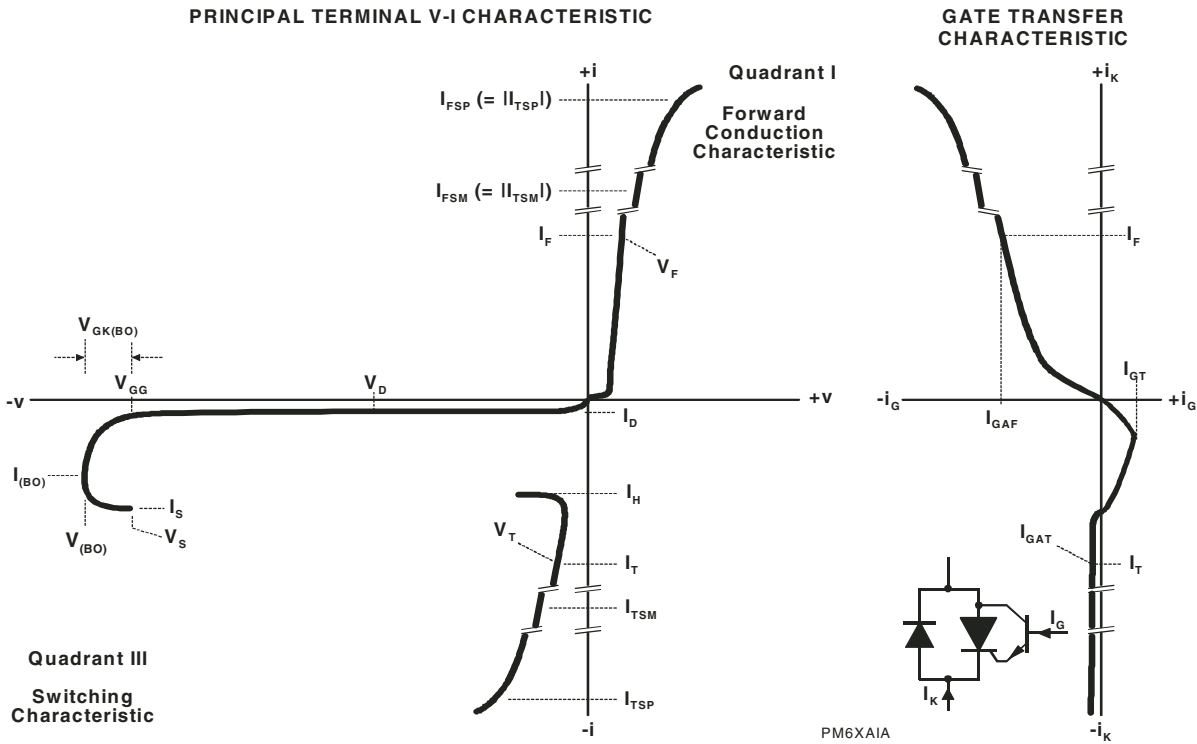

Figure 1. Principal Terminal And Gate Transfer Characteristics

APPLICATIONS INFORMATION

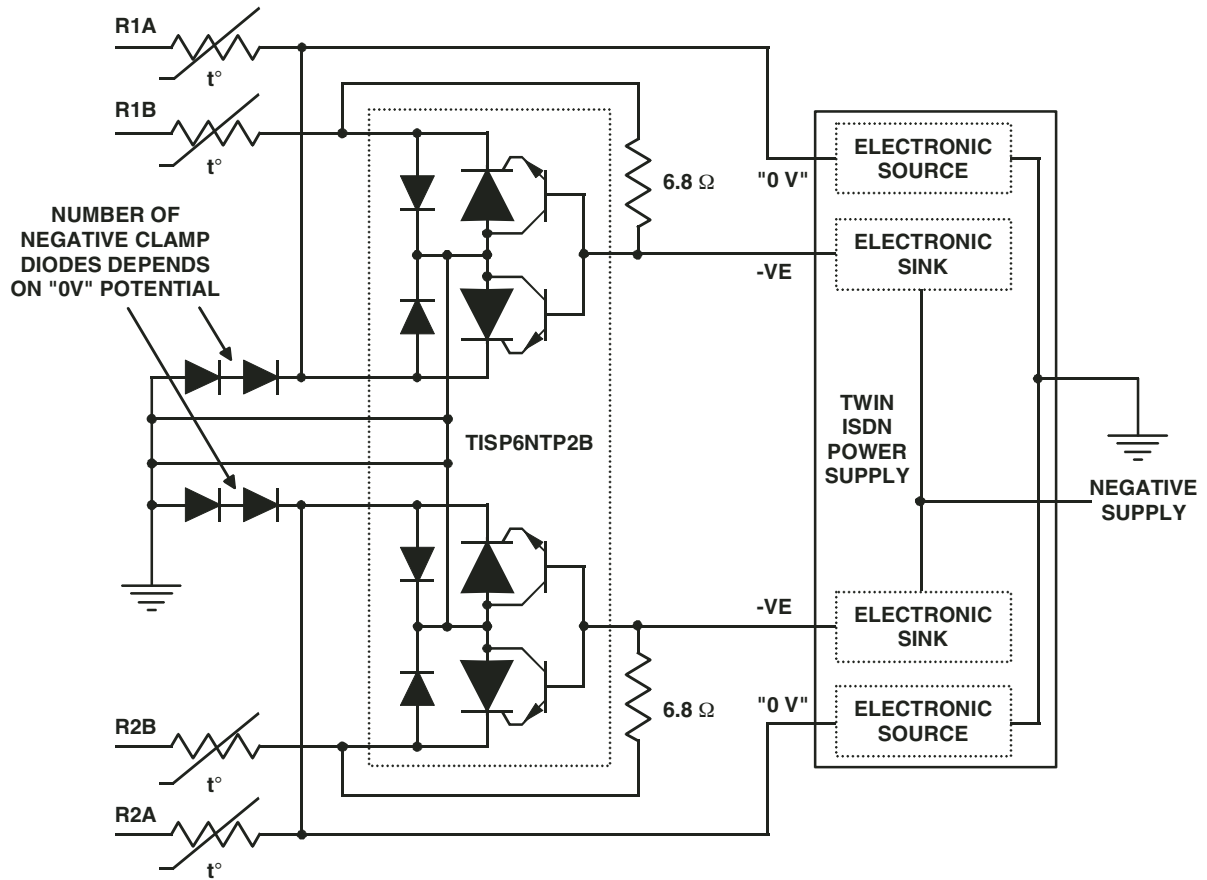

Figure 2. Protection of Two ISDN Power Feeds

APPLICATIONS INFORMATION

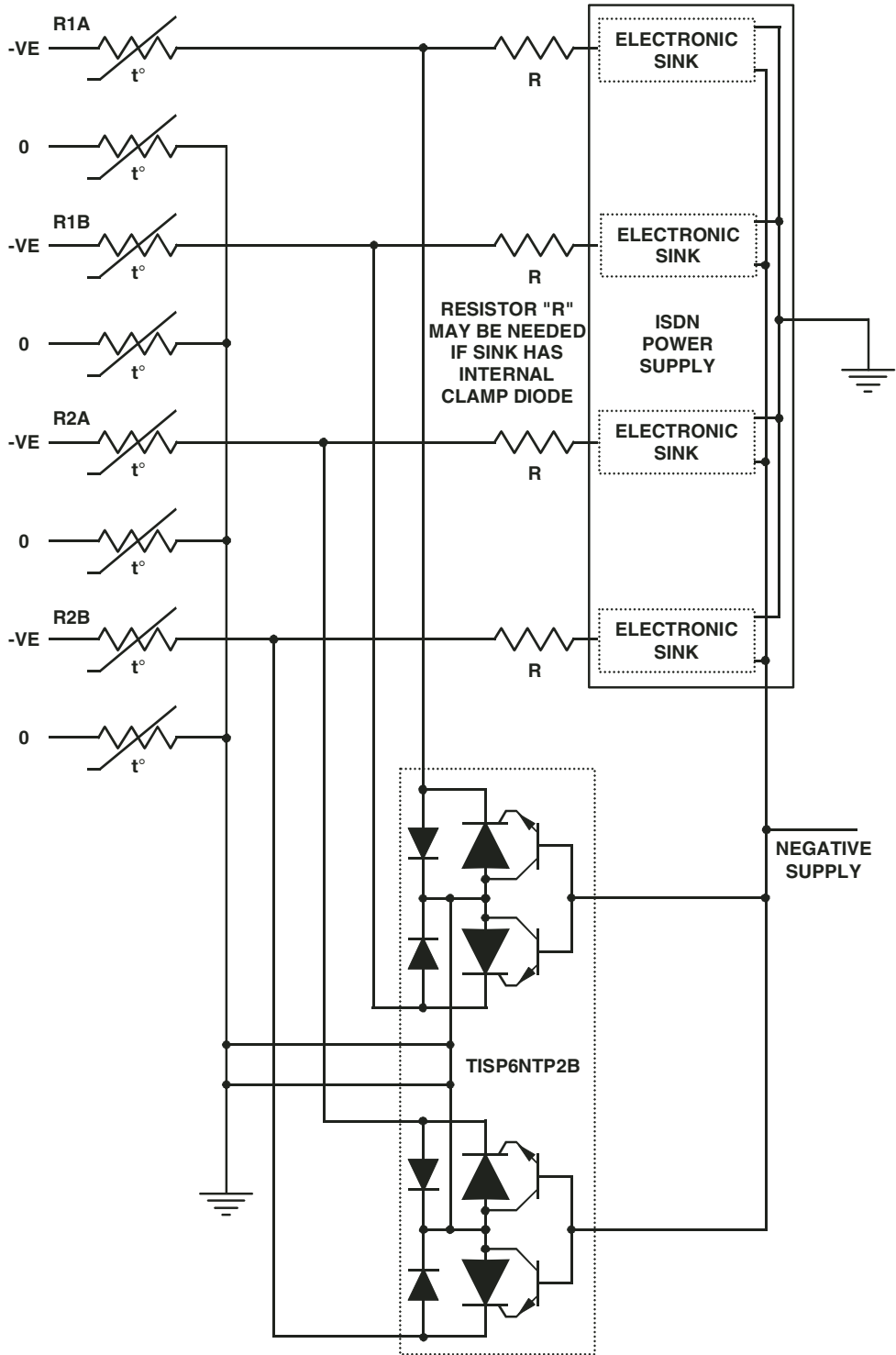

Figure 3. Protection of Four ISDN Power Feeds

TISP6NTP2B Programmable Protector

BOURNS®

MECHANICAL DATA

D008 Plastic Small-outline Package

This small-outline package consists of a circuit mounted on a lead frame and encapsulated within a plastic compound. The compound will withstand soldering temperature with no deformation, and circuit performance characteristics will remain stable when operated in high humidity conditions. Leads require no additional cleaning or processing when used in soldered assembly.

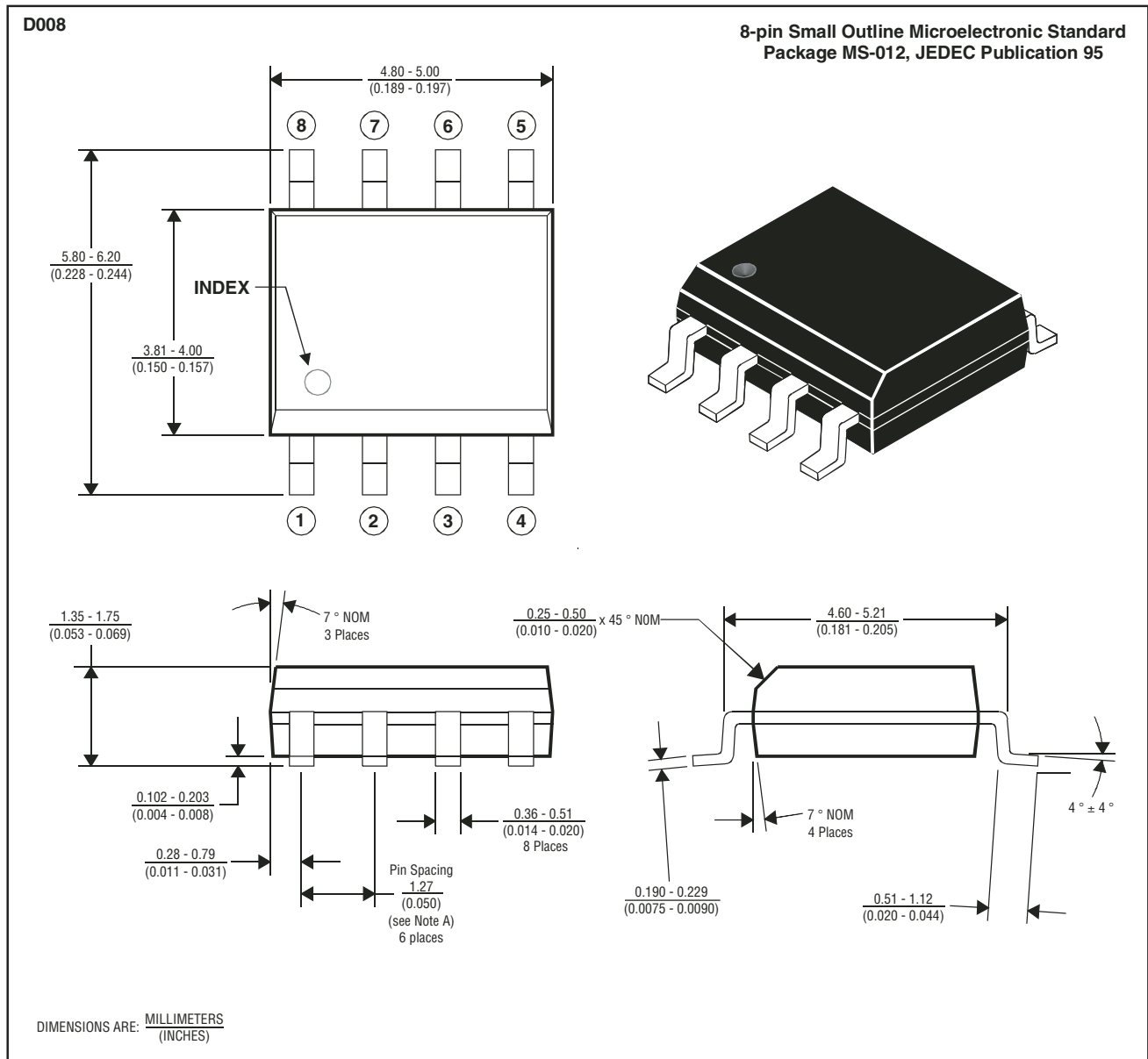

- NOTES: A. Leads are within 0.25 (0.010) radius of true position at maximum material condition.
 B. Body dimensions do not include mold flash or protrusion.
 C. Mold flash or protrusion shall not exceed 0.15 (0.006).
 D. Lead tips to be planar within ± 0.051 (0.002).

MDXXAAC

MECHANICAL DATA

D008 Tape Dimensions

D008 Package (8-pin Small Outline) Single-Sprocket Tape

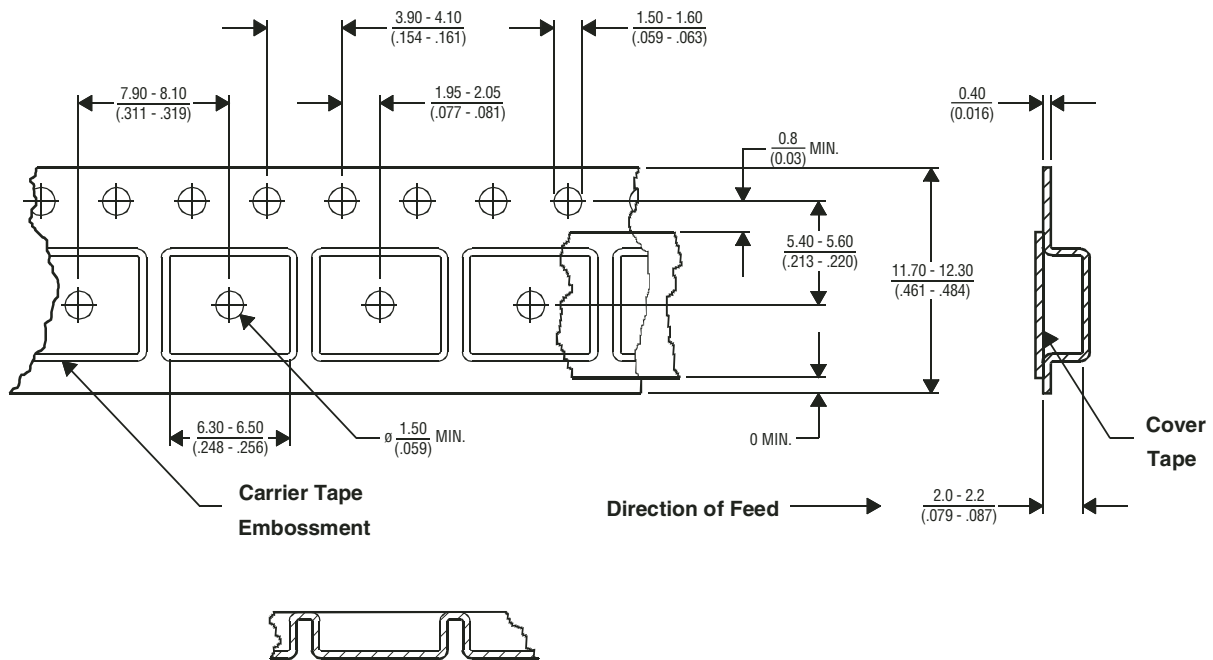

DIMENSIONS ARE: $\frac{\text{MILLIMETERS}}{\text{(INCHES)}}$

NOTES: A. Taped devices are supplied on a reel of the following dimensions:-

MDXXATB

Reel diameter: $\frac{330 \pm 0.0/-4.0}{(12.992 \pm 0.0/-157)}$

Reel hub diameter: $\frac{100 \pm 2.0}{(3.937 \pm .079)}$

Reel axial hole: $\frac{13.0 \pm 0.2}{(.512 \pm .008)}$

B. 2500 devices are on a reel.

"TISP" is a trademark of Bourns, Ltd., a Bourns Company, and is Registered in U.S. Patent and Trademark Office.
"Bourns" is a registered trademark of Bourns, Inc. in the U.S. and other countries.

JUNE 1998 - REVISED FEBRUARY 2005

Specifications are subject to change without notice.
Customers should verify actual device performance in their specific applications.