



**BOURNS®**

## Features

- Formerly *J.W. Miller* model
- Height of 3.0 mm max.
- Current rating up to 3.0 A
- RoHS compliant\*

## Applications

- Input/output of DC/DC converters
- Power supplies for:
  - Portable communication equipment
  - Camcorders
  - LCD TVs
  - Car radios

# PM528S Series - Shielded SMD Power Inductor

## Electrical Specifications

Bourns Part No.	Inductance 100 kHz		Q Ref.	Test Frequency (MHz)	SRF Typ. (MHz)	DCR Max. (mΩ)	I <sub>rms</sub> (A)	I <sub>sat</sub> (A)
	(μH)	Tol. %						
PM528S-2R6-RC	2.6	±30	7	7.96	77	30	3.00	2.70
PM528S-3R0-RC	3.0	±30	7	7.96	65	30	2.80	2.50
PM528S-4R2-RC	4.2	±30	7	7.96	51	35	2.50	2.20
PM528S-5R3-RC	5.3	±30	7	7.96	45	40	2.30	1.90
PM528S-6R2-RC	6.2	±30	7	7.96	39	45	2.20	1.80
PM528S-8R2-RC	8.2	±30	7	7.96	34	55	2.10	1.60
PM528S-100-RC	10	±30	9	2.52	30	70	1.50	1.40
PM528S-120-RC	12	±30	11	2.52	28	80	1.46	1.25
PM528S-150-RC	15	±30	9	2.52	22	100	1.37	1.15
PM528S-180-RC	18	±30	10	2.52	20	110	1.25	1.10
PM528S-220-RC	22	±30	7	2.52	20	120	1.15	1.00
PM528S-270-RC	27	±30	10	2.52	17	160	1.05	0.90
PM528S-330-RC	33	±30	11	2.52	13	190	0.90	0.78
PM528S-390-RC	39	±30	8	2.52	13	210	0.86	0.72
PM528S-470-RC	47	±30	7	2.52	13	250	0.82	0.65
PM528S-560-RC	56	±30	9	2.52	12	300	0.72	0.60
PM528S-680-RC	68	±30	8	2.52	11	350	0.62	0.56
PM528S-820-RC	82	±30	8	2.52	9	430	0.52	0.50
PM528S-101-RC	100	±30	8	0.796	8	480	0.45	0.45

## Soldering Profile

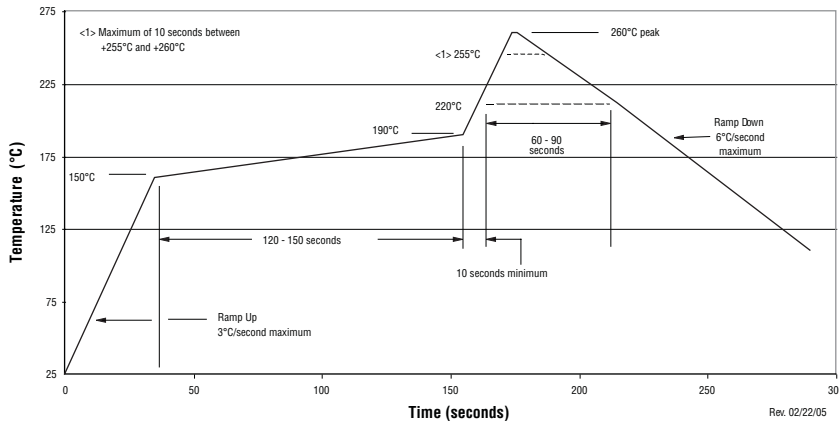

## General Specifications

Test Voltage ..... 0.1 V, 100 KHz  
 Reflow Soldering .... 230 °C; 50 sec max.  
 Operating Temperature ..... -40 °C to +125 °C  
 (Temperature rise included)  
 Storage Temperature .. -40 °C to +125 °C  
 Resistance to Soldering Heat ..... 260 °C for 10 sec.

## Materials

Core Material ..... Ferrite  
 Wire ..... Enameled Copper  
 Adhesive ..... Epoxy Resin  
 Terminal ..... Ag/Ni/Sn  
 Rated Current ..... Ind. drop of 35 % typ. at I<sub>sat</sub>  
 Temperature Rise ..... 30 °C typ. at I<sub>rms</sub>  
 Packaging ..... 400 pcs. per reel

## Product Dimensions

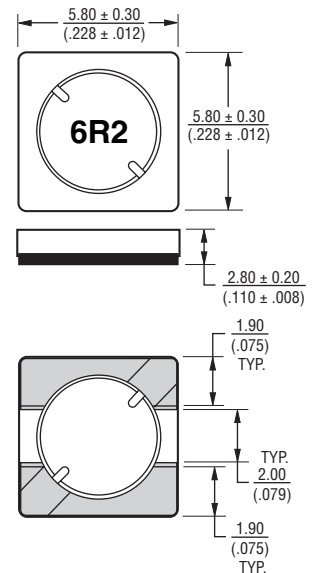

## Recommended Layout

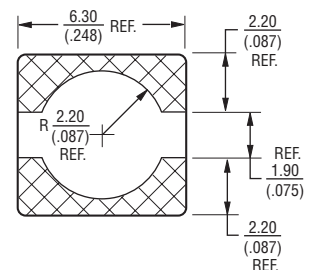

DIMENSIONS:  $\frac{\text{MM}}{\text{(INCHES)}}$

\*RoHS Directive 2002/95/EC Jan 27, 2003 including Annex. Specifications are subject to change without notice. Customers should verify actual device performance in their specific applications

# PM528S Series - Shielded SMD Power Inductor

**BOURNS®**

## Inductance vs. Current

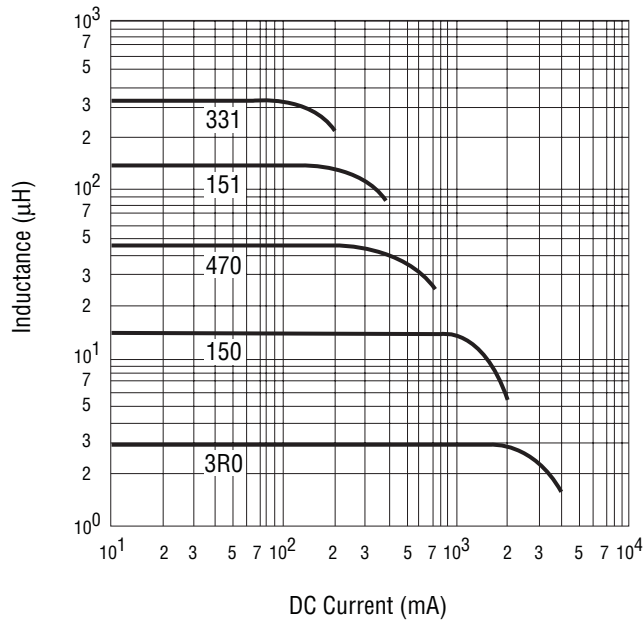

## Electrical Schematic

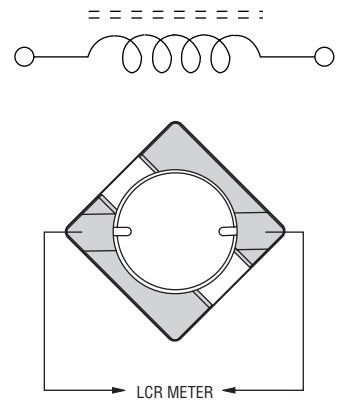

## Packaging Specifications

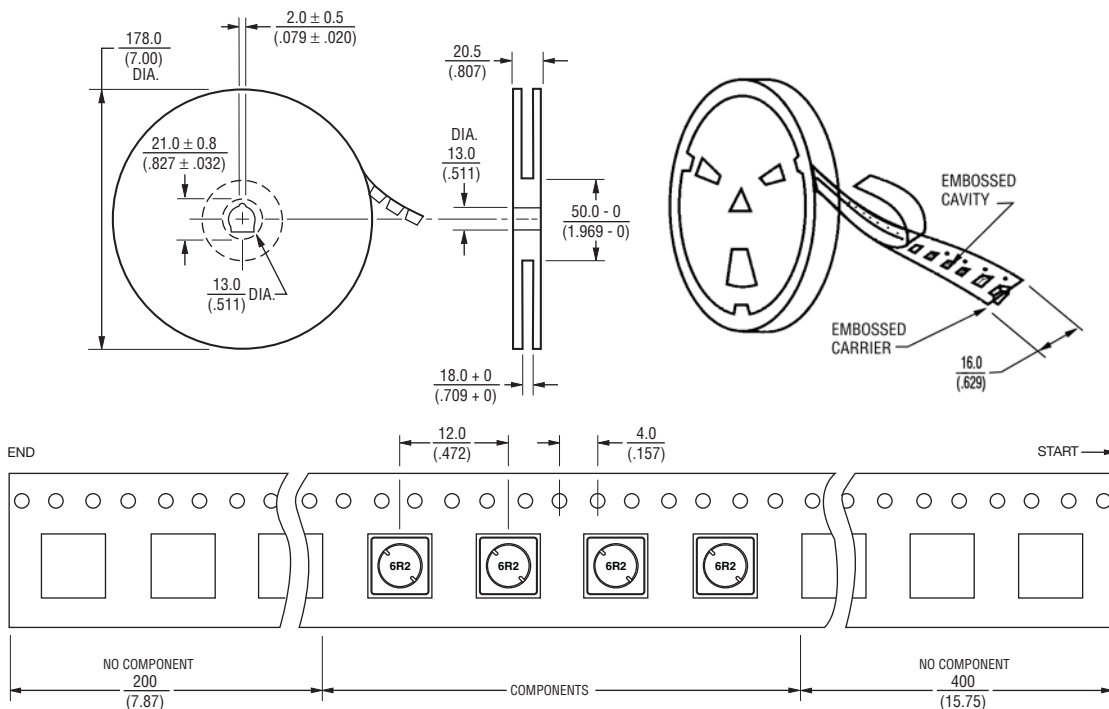

REV. 03/11

USER DIRECTION OF FEED →

QTY: 400 PCS. PER REEL

DIMENSIONS:  $\frac{\text{MM}}{\text{(INCHES)}}$

Specifications are subject to change without notice.  
Customers should verify actual device performance in their specific applications