



## SinglFuse™ SF-0603F Series Features

- Single blow fuse for overcurrent protection
- 1608 (EIA 0603) miniature footprint
- Fast-acting fuse
- UL certified
- RoHS compliant\* and halogen free
- Thin film chip fuse
- Surface mount packaging for automated assembly

## SF-0603F Series - Fast Acting Surface Mount Fuses

### Electrical Characteristics

Model	Rated Current (Amps)	Fusing Time	Resistance (mΩ) Typ.*	Rated Voltage	Breaking Capacity	Typical I <sup>2</sup> t (A <sup>2</sup> s)
SF-0603F050	0.50	Open within 5 sec. at 250 % rated current	250	DC 50 V	DC 50 V 50 A	0.005
SF-0603F063	0.63		173	DC 32 V	DC 32 V 50 A	0.007
SF-0603F080	0.80		115			0.014
SF-0603F100	1.00		88			0.016
SF-0603F125	1.25		63			0.027
SF-0603F150	1.50		45			0.037
SF-0603F160	1.60		42			0.041
SF-0603F200	2.00		33			0.044
SF-0603F250	2.50		24	DC 24 V	DC 24 V 50 A	0.055
SF-0603F300	3.00		21			0.082
SF-0603F315	3.15		19			0.089
SF-0603F400	4.00		15	DC 32 V	DC 32 V 50 A	0.239
SF-0603F500	5.00		12			0.433

\*Resistance value was measured with less than 10 % of rated current.

### Reliability Testing

Parameter	Requirement	Test Method
Carrying Capacity.....	No fusing.....	Rated current, 4 hours
Fusing Time.....	Within 1 minute.....	200 % of its rated current
Interrupting Ability.....	No mechanical damages.....	After the fuse is interrupted, rated voltage applied for 30 seconds again
Bending Test.....	No mechanical damages.....	Distance between holding points: 90 mm, Bending: 3 mm, 1 time, 30 seconds
Resistance to Solder Heat.....	±20 %.....	260 °C ±5 °C, 10 seconds ±1 second
Solderability.....	95 % coverage minimum.....	235 °C ±5 °C, 2 ±0.5 second 245 °C ±5 °C, 2 ±0.5 second (lead free)
Temperature Rise.....	<75 °.....	100 % of its rated current, measure of surface temperature
Resistance to Dry Heat.....	±20 %.....	105 °C ±5 °C, 1000 hours
Resistance to Solvent.....	No evident damage on protective.....	23 °C ±5 °C of isopropyl alcohol, 90 seconds coating and marking
Residual Resistance.....	10k W or more.....	Measure DC resistance after fusing
Thermal Shock.....	DR < 10 %.....	-20 °C / +25 °C / +125 °C / +25 °C, 10 cycles

### Typical Part Marking

Represents total content. Layout may vary.



RATING CURRENT (A)  
 F = 0.50    S = 2.00  
 I = 0.63    T = 2.50  
 K = 0.80    3 = 3.00  
 L = 1.00    U = 3.15  
 M = 1.25    W = 4.00  
 P = 1.50    Y = 5.00  
 N = 1.60

### How to Order

**SF - 0603 F 050 - 2**

SinglFuse™ Product Designator

SMD Footprint 1608 (EIA 0603) size

Fuse Blow Type  
 F = Fast acting  
 S = Slow blow

Rated Current  
 050-500 (500 mA - 5.00 A)

Packaging Type  
 - 2 = Tape & Reel (5,000 pcs./reel)



#### Asia-Pacific:

Tel: +886-2 2562-4117  
 Fax: +886-2 2562-4116

#### Europe:

Tel: +41-41 768 5555  
 Fax: +41-41 768 5510

#### The Americas:

Tel: +1-951 781-5500  
 Fax: +1-951 781-5700

[www.bourns.com](http://www.bourns.com)

\*RoHS Directive 2002/95/EC Jan 27 2003 including Annex.  
 "SinglFuse" is a trademark of Bourns, Inc.

Specifications are subject to change without notice.

Customers should verify actual device performance in their specific applications

# SingFuse™ SF-0603F Series Applications

- Portable memory
- LCD monitors
- Disk drives
- PDAs
- Digital cameras
- DVDs
- Cell phones
- Rechargeable battery packs
- Battery chargers
- Set top boxes
- Industrial controllers

## SF-0603F Series - Fast Acting Surface Mount Fuses **BOURNS®**

### Solder Reflow Recommendations

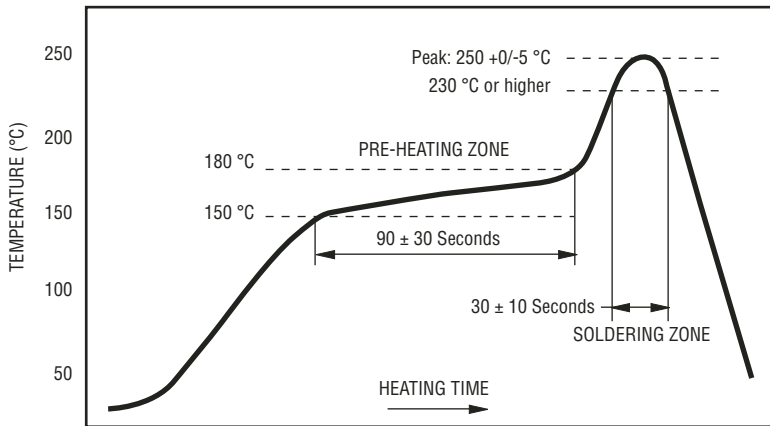

PEAK: 250 +0/-5 °C, 5 seconds  
 PRE-HEATING ZONE: 150 to 180 °C, 90 ± 30 seconds  
 SOLDERING ZONE: 230 °C or higher, 30 ± 10 seconds

### Product Dimensions

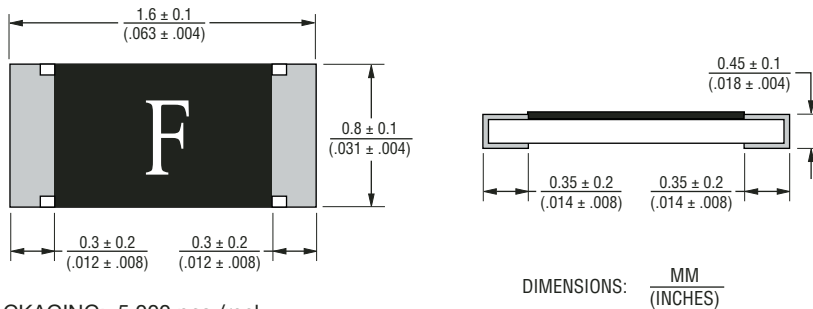

PACKAGING: 5,000 pcs./reel

### Recommended Pad Layout

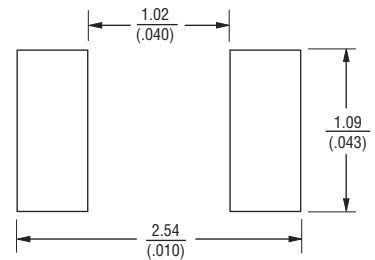

### Thermal Derating Curve

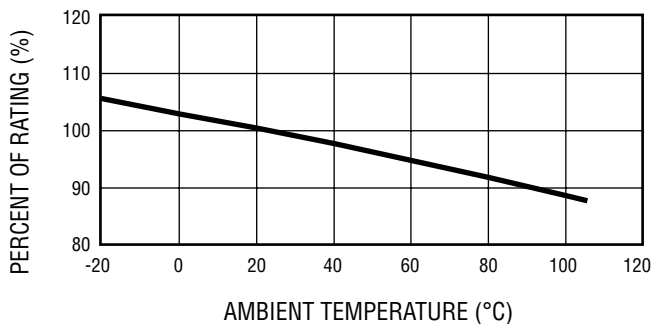

### Construction & Material Content

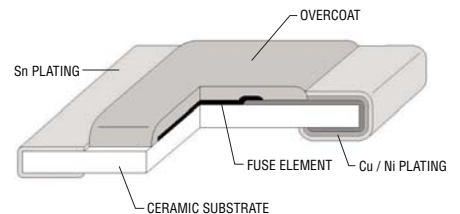

# SF-0603F Series - Fast Acting Surface Mount Fuses



Average Time Current Curves

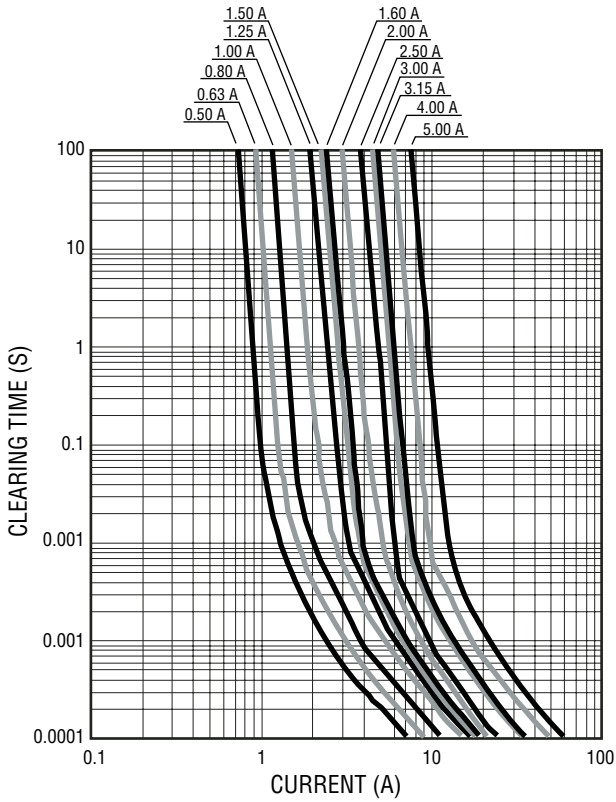

Minimum I<sup>2</sup>T V Clear Time Curves

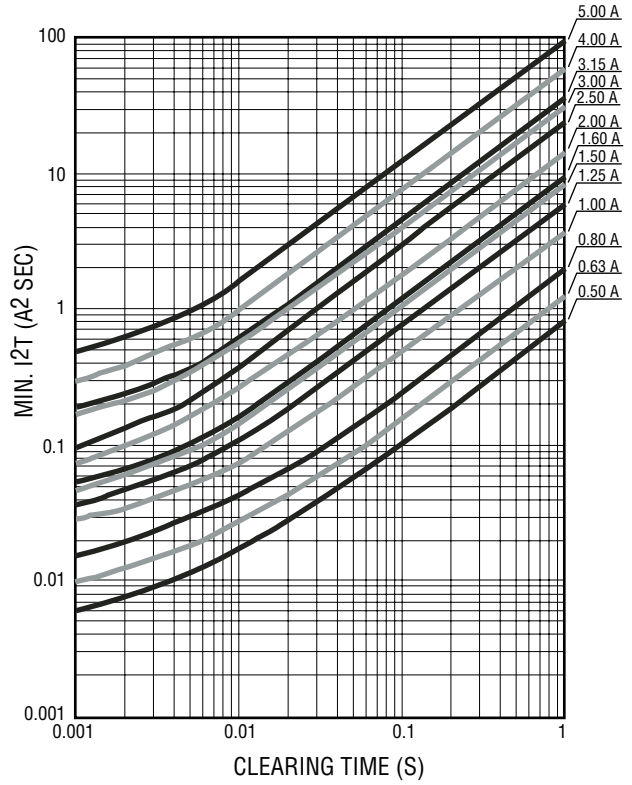

REV. B 11/08

Specifications are subject to change without notice.  
Customers should verify actual device performance in their specific applications

# SF-0603F Series Tape and Reel Specifications

# BOURNS®

Tape Dimensions	SF-0603F Series per EIA 481-2
W	$\frac{8.0 \pm 0.2}{(.315 \pm .008)}$
P <sub>0</sub>	$\frac{4.0 \pm 0.1}{(.157 \pm .004)}$
P <sub>1</sub>	$\frac{4.0 \pm 0.1}{(.157 \pm .004)}$
P <sub>2</sub>	$\frac{2.0 \pm 0.05}{(.079 \pm .002)}$
A	$\frac{1.1 \pm 0.1}{(.043 \pm .004)}$
B	$\frac{1.9 \pm 0.1}{(.075 \pm .004)}$
F	$\frac{3.5 \pm 0.05}{(.138 \pm .002)}$
E	$\frac{1.75 \pm 0.1}{(.069 \pm .004)}$
D <sub>0</sub>	$\frac{1.5 + 0.1/-0}{(.059 + .004/-0)}$
T	$\frac{0.64 \pm 0.1}{(.025 \pm .004)}$
<b>Reel Dimensions</b>	
A	$\frac{180 +0/-3.0}{(7.087 +0/-.118)}$
B Min.	$\frac{60.0}{(2.362)}$
C	$\frac{13.0 \pm 1.0}{(.512 \pm .039)}$
W	$\frac{9.0 \pm 1.0}{(.354 \pm .039)}$
T	$\frac{11.4 \pm 2.0}{(.449 \pm .079)}$

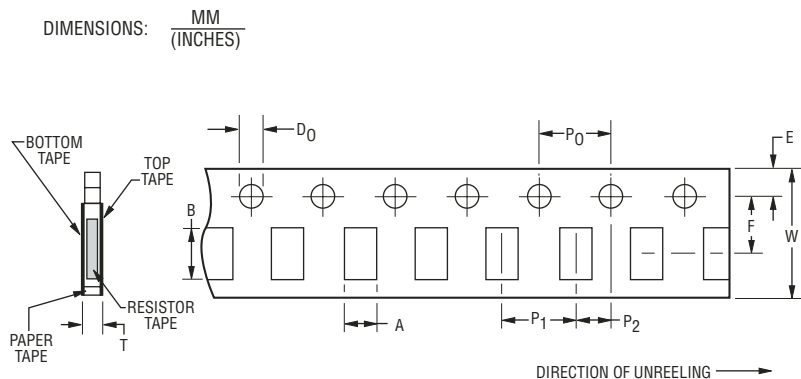
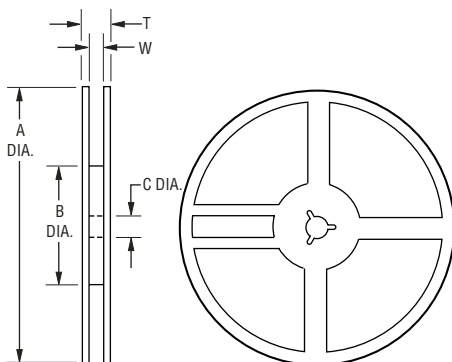

Specifications are subject to change without notice.  
Customers should verify actual device performance in their specific applications