

Features

- 5 mm diameter, 4 mm long (2035 series)
- 5 mm diameter, 5 mm long (2037 series)
- UL Recognized
- High surge current rating
- Stable breakdown throughout life
- RoHS compliant*

Applications

- Telecommunications
- Industrial electronics
- Commercial electronics
- Consumer electronics

Sustainability

- Small size reduces material use
- Corrosion-resistant for longevity
- ISO 14001, low-impact energy
- Responsibly sourced and produced

Product Overview

The Bourns® 2035 & 2037 Series Miniature 2-Pole Gas Discharge Tubes (GDTs) are compact, high-energy primary protection devices designed to provide dependable overvoltage protection across a broad range of operating voltages. Available in 5 mm diameter packages with two body length options, this series enables flexible design integration in space-conscious applications.

With DC sparkover voltages ranging from 90 V to 600 V and surge current capability up to 10 kA (8/20 μ s), the 2035 & 2037 Series deliver

robust performance against lightning-induced transients, power cross conditions and industrial surge environments. The devices maintain stable breakdown characteristics throughout their service life, helping to ensure consistent protection margins over time.

The 2035 & 2037 Series provide a reliable, high-insulation and low-capacitance (<1 pF) solution for telecommunications, industrial, commercial and consumer electronic equipment requiring solid primary surge protection.

Characteristics

Test Methods per ITU-T K.12, IEEE C62.31 and IEC 61643-311 GDT standards.

Characteristic	Model No.					
	2035-2037-09	2035/2037-15	2035/2037-20	2035/2037-23	2035/2037-25	2035/2037-30
DC Sparkover $\pm 15\%$ ($\pm 20\%$ for Model 2035/2037-09) @ 100 V/s	90 V	150 V	200 V	230 V	250 V	300 V
Impulse Sparkover ⁽¹⁾						
100 V/ μ s	300 V	350 V	425 V	450 V	475 V	525 V
1000 V/ μ s	550 V	550 V	575 V	600 V	625 V	650 V

Characteristic	Model No.				
	2035/2037-35	2035/2037-40	2035/2037-42	2035/2037-47	2035/2037-60
DC Sparkover $\pm 15\%$ @ 100 V/s	350 V	400 V	420 V	470 V	600 V
Impulse Sparkover ⁽¹⁾					
100 V/ μ s	600 V	650 V	675 V	750 V	950 V
1000 V/ μ s	750 V	800 V	850 V	950 V	1100 V

⁽¹⁾ Impulse Sparkover voltage is defined as typical values of distribution.

~ Continued ~

Contact Information

www.bourns.com	Phone	Email
Asia-Pacific	+886-2 2562-4117	asiacus@bourns.com
Europe	+36 88 885 877	euocus@bourns.com

www.bourns.com	Phone	Email
Mexico	+52 614 478 0400	mexicus@bourns.com
The Americas	+1-951 781-5500	americus@bourns.com

* RoHS Directive 2015/863, Mar 31, 2015 and Annex. Specifications are subject to change without notice. Users should verify actual device performance in their specific applications.

The products described herein and this document are subject to specific legal disclaimers as set forth on the last page of this document, and at www.bourns.com/docs/legal/disclaimer.pdf.

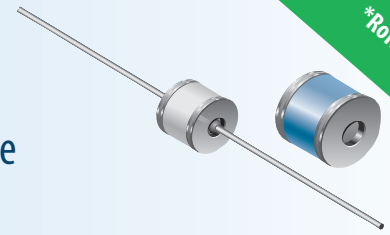

Characteristics (Continued)

Characteristic	Value
Insulation Resistance (IR) 100 V 50 V (2035/2037-09)	> 10 ¹⁰ Ω
Glow Voltage 10 mA	~ 70 V
Arc Voltage 1 A	~ 10 V
Glow-Arc Transition Current	< 0.5 A
Capacitance 1 MHz	< 1 pF
DC Holdover Voltage ⁽²⁾ 135 V 52 V (2035/2037-09) 80 V (2035/2037-15)	< 150 ms
Impulse Discharge Current 10,000 A, 8/20 μs ⁽³⁾ 5,000 A, 8/20 μs 1,000 A, 10/350 μs 100 A, 10/1000 μs 100 A, 10/700 μs	1 operation min. >10 operations 1 operation >300 operations 500 operations
Alternating Discharge Current 20 Arms, 11 cycles ⁽³⁾ 5 Arms, 1 s	1 operation min. >10 operations
Operating Temperature	-55 to +85 °C
Climatic Category (IEC 60068-1)	40/90/21

Notes:

- UL recognized component, file [E153537](#).
- Model number marking on tube: xxxV.
- Sparkover limits after life: ±20 % (-25 %, +30 % for Model 2035/2037-09 and 2035/2037-60, IR >10⁸Ω.
- Other DC sparkover ranges available on request.
- At delivery AQL 0.65 Level II, DIN ISO 2859.

⁽²⁾ Network applied.

⁽³⁾ DC Sparkover may exceed ±20 % but will continue to protect without venting.

How to Order

2035/37 - xx - x (n) T1 LF

Model Number Designator _____

Voltage (Divided by 10) _____

09 = 90 V
25 = 250 V
42 = 420 V
15 = 150 V
30 = 300 V
47 = 470 V
20 = 200 V
35 = 350 V
60 = 600 V
23 = 230 V
40 = 400 V

Leads _____

A = None
B = 0.8 mm

Lead Shape _____
(See Product Dimension Drawings)

Packaging _____

Blank = Bulk Packaging (Standard)
T1 = Reelpack (Optional)

RoHS Compliant Designator _____

LF = RoHS Compliant Product

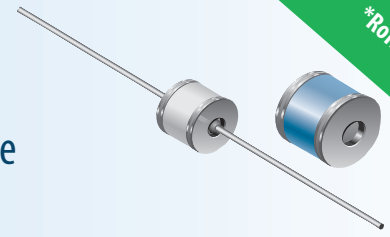

Product Dimensions

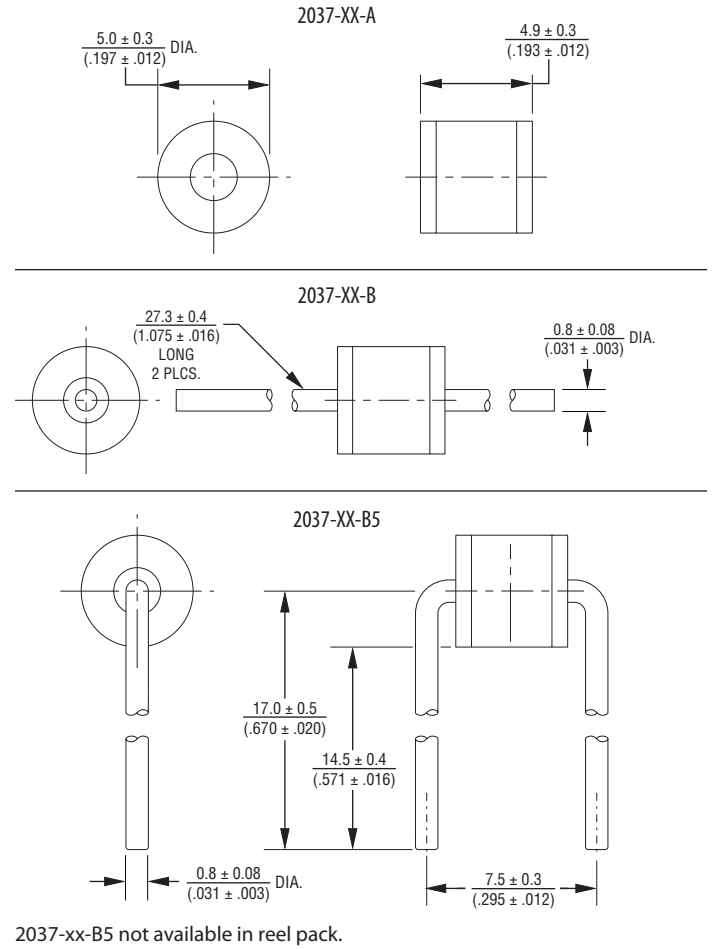
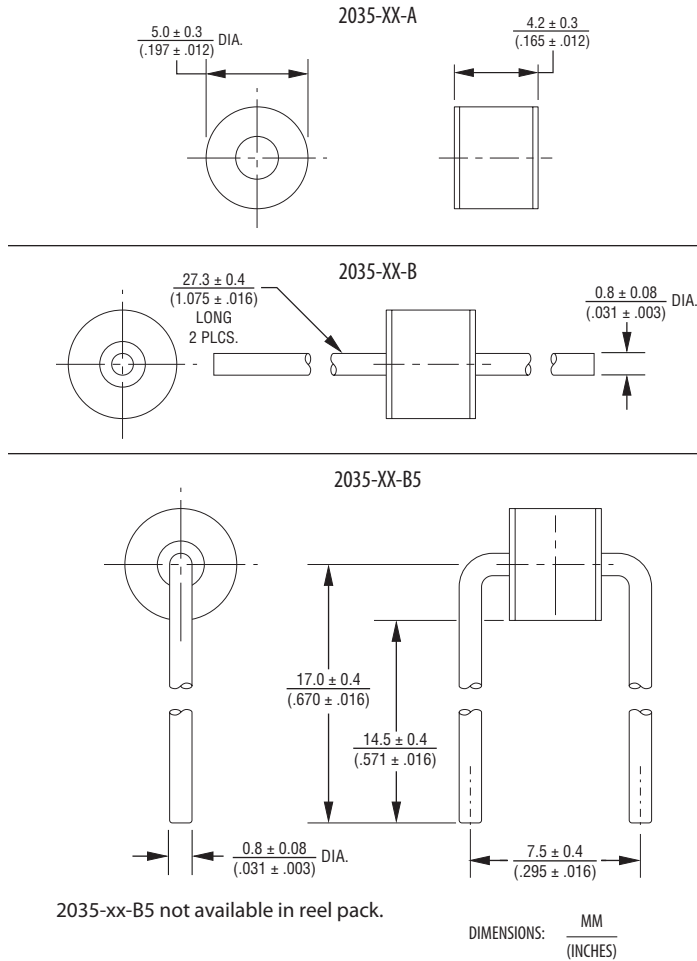

Packaging Specifications

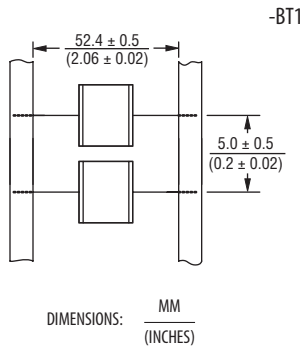

Model	Standard Packaging Quantity			
	Bulk (Bag)	Tray	Box	Reel
2035/2037-XX-A	250		1000	
2035/2037-XX-B	100		700	
2035/2037-XX-B5	250		1000	
2035/2037-XX-BT1				1000

This legal disclaimer applies to purchasers and users of Bourns® products manufactured by or on behalf of Bourns, Inc. and its affiliates (collectively, "Bourns").

Unless otherwise expressly indicated in writing, Bourns® products and data sheets relating thereto are subject to change without notice. Users should check for and obtain the latest relevant information and verify that such information is current and complete before placing orders for Bourns® products.

The characteristics and parameters of a Bourns® product set forth in its data sheet are based on laboratory conditions, and statements regarding the suitability of products for certain types of applications are based on Bourns' knowledge of typical requirements in generic applications. The characteristics and parameters of a Bourns® product in a user application may vary from the data sheet characteristics and parameters due to (i) the combination of the Bourns® product with other components in the user's application, or (ii) the environment of the user application itself. The characteristics and parameters of a Bourns® product also can and do vary in different applications and actual performance may vary over time. Users should always verify the actual performance of the Bourns® product in their specific devices and applications, and make their own independent judgments regarding the amount of additional test margin to design into their device or application to compensate for differences between laboratory and real world conditions.

Unless Bourns has explicitly designated an individual Bourns® product as meeting the requirements of a particular industry standard (e.g., ISO/TS 16949) or a particular qualification (e.g., UL listed or recognized), Bourns is not responsible for any failure of an individual Bourns® product to meet the requirements of such industry standard or particular qualification. Users of Bourns® products are responsible for ensuring compliance with safety-related requirements and standards applicable to their devices or applications.

Bourns® products are not recommended, authorized or intended for use in nuclear, lifesaving, life-critical or life-sustaining applications, nor in any other applications where failure or malfunction may result in personal injury, death, or severe property or environmental damage. Unless expressly and specifically approved in writing by two authorized Bourns representatives on a case-by-case basis, use of any Bourns® products in such unauthorized applications might not be safe and thus is at the user's sole risk. Life-critical applications include devices identified by the U.S. Food and Drug Administration as Class III devices and generally equivalent classifications outside of the United States.

Bourns expressly identifies those Bourns® standard products that are suitable for use in automotive applications on such products' data sheets in the section entitled "Applications." Unless expressly and specifically approved in writing by two authorized Bourns representatives on a case-by-case basis, use of any other Bourns® standard products in an automotive application might not be safe and thus is not recommended, authorized or intended and is at the user's sole risk. If Bourns expressly identifies a sub-category of automotive application in the data sheet for its standard products (such as infotainment or lighting), such identification means that Bourns has reviewed

its standard product and has determined that if such Bourns® standard product is considered for potential use in automotive applications, it should only be used in such sub-category of automotive applications. Any reference to Bourns® standard product in the data sheet as compliant with the AEC-Q standard or "automotive grade" does not by itself mean that Bourns has approved such product for use in an automotive application.

Bourns® standard products are not tested to comply with United States Federal Aviation Administration standards generally or any other generally equivalent governmental organization standard applicable to products designed or manufactured for use in aircraft or space applications. Bourns expressly identifies Bourns® standard products that are suitable for use in aircraft or space applications on such products' data sheets in the section entitled "Applications." Unless expressly and specifically approved in writing by two authorized Bourns representatives on a case-by-case basis, use of any other Bourns® standard product in an aircraft or space application might not be safe and thus is not recommended, authorized or intended and is at the user's sole risk.

The use and level of testing applicable to Bourns® custom products shall be negotiated on a case-by-case basis by Bourns and the user for which such Bourns® custom products are specially designed. Absent a written agreement between Bourns and the user regarding the use and level of such testing, the above provisions applicable to Bourns® standard products shall also apply to such Bourns® custom products.

Users shall not sell, transfer, export or re-export any Bourns® products or technology for use in activities which involve the design, development, production, use or stockpiling of nuclear, chemical or biological weapons or missiles, nor shall they use Bourns® products or technology in any facility which engages in activities relating to such devices. The foregoing restrictions apply to all uses and applications that violate national or international prohibitions, including embargos or international regulations. Further, Bourns® products and Bourns technology and technical data may not under any circumstance be exported or re-exported to countries subject to international sanctions or embargoes. Bourns® products may not, without prior authorization from Bourns and/or the U.S. Government, be resold, transferred, or re-exported to any party not eligible to receive U.S. commodities, software, and technical data.

To the maximum extent permitted by applicable law, Bourns disclaims (i) any and all liability for special, punitive, consequential, incidental or indirect damages or lost revenues or lost profits, and (ii) any and all implied warranties, including implied warranties of fitness for particular purpose, non-infringement and merchantability.

For your convenience, copies of this Legal Disclaimer Notice with German, Spanish, Japanese, Traditional Chinese and Simplified Chinese bilingual versions are available at:

Web Page: <http://www.bourns.com/legal/disclaimers-terms-and-policies>

PDF: <http://www.bourns.com/docs/Legal/disclaimer.pdf>

