



## Features

- Wirewound and Hybritron® elements
- High rotational life
- Optional 0.20 % linearity
- Optional A/R lug
- RoHS compliant\*
- Suitable for use under side load
- Designed for HMI and MMI applications
- Dual gang option
- Servo mount option

## 3547 - 3-Turn Precision Potentiometer

Electrical Characteristics <sup>1</sup>	Wirewound Element	Hybritron® Element
Standard Resistance Range.....	1K to 50K ohms.....	1K to 10K ohms
Total Resistance Tolerance.....	±3 %.....	±10 %
Independent Linearity.....	±0.25 %.....	±0.25 %
Independent Linearity (Maximum Practical).....	±0.20 %.....	±0.20 %
Effective Electrical Angle.....	1080 ° +10 °, -0 °.....	1080 ° +10 °, -0 °
Absolute Minimum Resistance/End Voltage.....	1 ohm or 0.1 % maximum.....	0.7 % maximum
	(whichever is greater)	
Noise/Output Smoothness.....	100 ohms maximum.....	0.15 % maximum
Max. Wiper Current @ 5K ohms.....	20 mA.....	10 mA
Dielectric Withstanding Voltage (MIL-STD-202, Method 301)		
Sea Level.....	1,000 VAC minimum.....	1,000 VAC minimum
Insulation Resistance (500 VDC).....	1,000 megohms minimum.....	1,000 megohms minimum
Resolution.....	See How to Order chart.....	Essentially infinite
Power Rating (Voltage Limited By Power Dissipation)		
+70 °C.....	1 watts.....	1 watts
+125 °C.....	0 watt.....	0 watt

Environmental Characteristics <sup>1</sup>	Wirewound Element	Hybritron® Element
Operating Temperature Range		
Dynamic.....	-40 °C to +125 °C.....	-40 °C to +125 °C
Static.....	-55 °C to +125 °C.....	-55 °C to +125 °C
Temperature Coefficient (Over Static Temperature Range).....	±50 ppm/°C.....	±100 ppm/°C
Temperature Cycling (5 Cycles Over Static Temperature Range).....	±2 % TR shift max.....	±4 % TR shift max.
Vibration (15 Gs, 10 Hz to 2 kHz)		
Wiper Bounce.....	0.1 ms max.....	0.1 ms max.
Shock (100 Gs, 6 ms sawtooth)		
Wiper Bounce.....	0.1 ms max.....	0.1 ms max.
Load Life (1,000 hours @ 70 °C).....	±2 % TR shift max.....	±5 % TR shift max.
Rotational Life		
No Load.....	750,000 shaft revolutions.....	1,500,000 shaft revolutions
Powered (MIL-PRF-12934).....	600,000 shaft revolutions.....	1,200,000 shaft revolutions
Moisture Resistance (Mil-Std-202, Method 103).....	±2 % TR shift max.....	±5 % TR shift max.
IP Rating.....	IP 50.....	IP 50

Mechanical Characteristics <sup>1</sup>	Wirewound Element	Hybritron® Element
Mechanical Angle.....	1080 ° +10 °, -0 °	
Backlash.....	1.0 ° max.	
Stop Strength.....	53 N-cm (75 oz.-in.) min.	
Torque		
Starting.....	0.5 N-cm (0.7 oz.-in.) max.	
Running.....	0.5 N-cm (0.7 oz.-in.) max.	
Clutch.....	1.0 to 4.2 N-cm (1.5 to 6.0 oz.-in.)	
Mounting.....	170-200 N-cm (15-18 in.-lb.) max.	
Shaft Runout T.I.R.....	0.08 mm (0.003 in.)	
Lateral Runout T.I.R.....	0.13 mm (0.005 in.)	
Shaft End Play T.I.R.....	0.15 mm (0.006 in.)	
Shaft Radial Play T.I.R.....	0.08 mm (0.003 in.)	
Pilot Diameter Runout T.I.R.....	0.08 mm (0.003 in.)	
Weight		
Single.....	18 gm (0.63 oz.) typ.	
Dual.....	34 gm (1.2 oz.) typ.	
Shaft Side Load (Max. Allowable)		
Nickel Plated Brass Shaft w/Brass Bushing.....	50 gmf (1.7 ozf)	
Stainless Steel Shaft w/Bronze Bushing.....	250 gmf (8.8 ozf)	
Terminals.....	Gold-plated solder lugs	
Soldering Condition		
Manual Soldering.....	96.5Sn/3.0Ag/0.5Cu solid wire or no-clean rosin cored wire, 370 °C (700 °F) max. for 3 seconds	
Wave Soldering.....	96.5Sn/3.0Ag/0.5Cu solder with no-clean flux, 260 °C (500 °F) max. for 5 seconds	
Wash processes.....	Not recommended	
Mounting Hardware.....	One lockwasher and one mounting nut is shipped with each potentiometer	
Recommended Panel Thickness (Bushing Mount).....	2.46-3.81 mm (0.097-0.150 in.)	
Marking.....	Manufacturer's symbol, model number, product code and date code	
Standard Packaging.....	Plastic trays (5 pcs./tray)	

<sup>1</sup>At room ambient: +25 °C nominal and 50 % relative humidity nominal, except as noted.  
For other options, please consult factory.



**WARNING**  
**Cancer and Reproductive Harm**  
[www.P65Warnings.ca.gov](http://www.P65Warnings.ca.gov)

\*RoHS Directive 2015/863, Mar 31, 2015 and Annex.

Specifications are subject to change without notice. Users should verify actual device performance in their specific applications. The products described herein and this document are subject to specific legal disclaimers as set forth on the last page of this document, and at [www.bourns.com/docs/legal/disclaimer.pdf](http://www.bourns.com/docs/legal/disclaimer.pdf)

# 3547 - 3-Turn Precision Potentiometer

**BOURNS®**

## Product Dimensions

### Single Gang, Bushing Mount

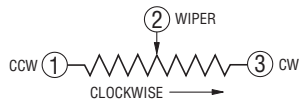
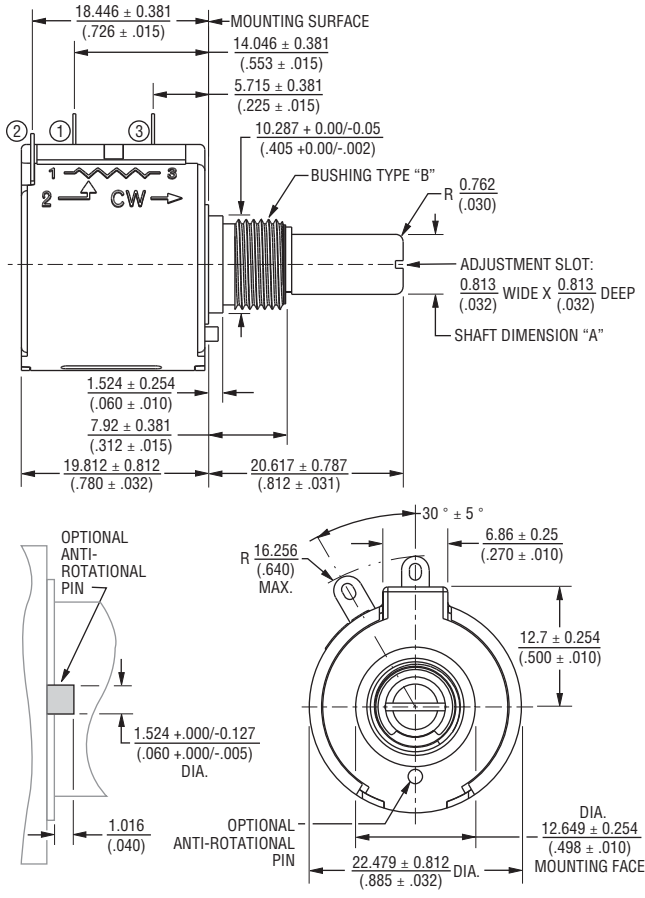

TOLERANCES: EXCEPT WHERE NOTED  
 DECIMALS: .XX  $\pm$  (.02) .XXX  $\pm$  (.005) .XXXX  $\pm$  (.0005)  
 DIMENSIONS:  $\frac{MM}{(IN)}$

Bushing Selection Code	Shaft Dimension "A"	Shaft Material	Bushing Type "B"	Bushing Material
A	$6.34 \pm 0/-0.022$ ( $0.2497 \pm 0/-0.0009$ )	Nickel Plated Brass	3/8" 32-UNEF- 2A THD.	Brass
B	$6.00 \pm 0/-0.022$ ( $0.2362 \pm 0/-0.0009$ )	Nickel Plated Brass	M9 X 0.75-8g	Brass
C	$6.34 \pm 0/-0.007$ ( $0.2497 \pm 0/-0.0003$ )	Stainless Steel	3/8" 32-UNEF- 2A THD.	Bronze
D	$6.00 \pm 0/-0.007$ ( $0.2362 \pm 0/-0.0003$ )	Stainless Steel	M9 X 0.75-8g	Bronze
G	$6.34 \pm 0/-0.007$ ( $0.2497 \pm 0/-0.0003$ )	Stainless Steel	3/8" 32-UNEF- 2A THD.	Bronze
H	$6.00 \pm 0/-0.007$ ( $0.2362 \pm 0/-0.0003$ )	Stainless Steel	M9 X 0.75-8g	Bronze

### Dual Gang, Bushing Mount

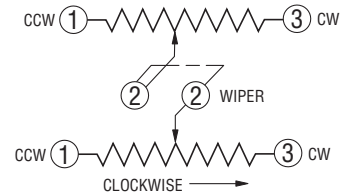
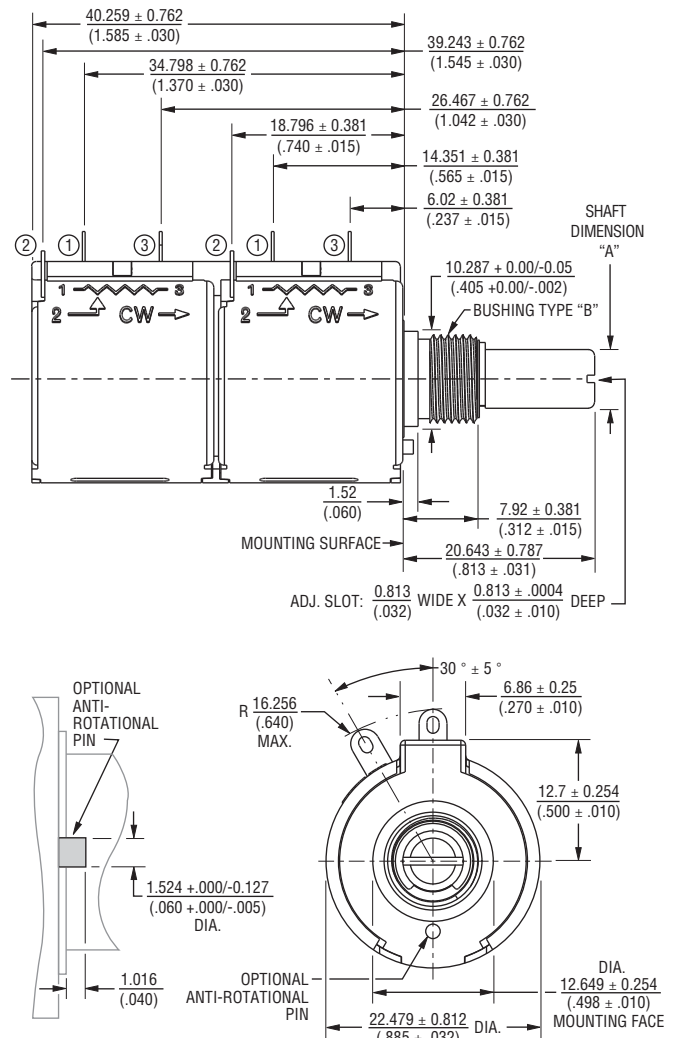

Specifications are subject to change without notice.

Users should verify actual device performance in their specific applications.

The products described herein and this document are subject to specific legal disclaimers as set forth on the last page of this document, and at [www.bourns.com/docs/legal/disclaimer.pdf](http://www.bourns.com/docs/legal/disclaimer.pdf).

# 3547 - 3-Turn Precision Potentiometer

**BOURNS®**

## Product Dimensions

### Single Gang, Servo Mount

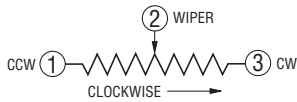
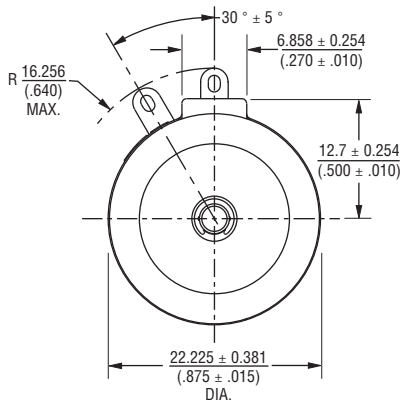
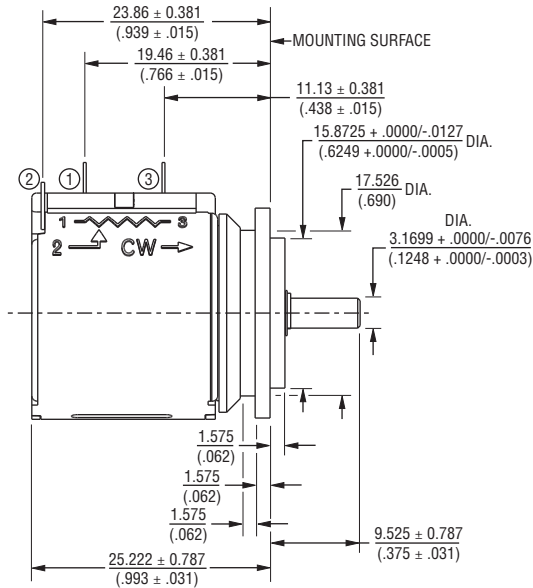

TOLERANCES: EXCEPT WHERE NOTED  
 DECIMALS: .XX ± (.02) .XXX ± (.005) .XXXX ± (.0005)  
 DIMENSIONS:  $\frac{MM}{(IN)}$

### Dual Gang, Servo Mount

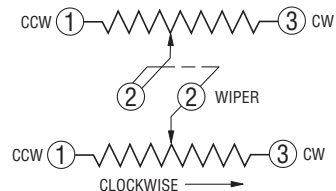
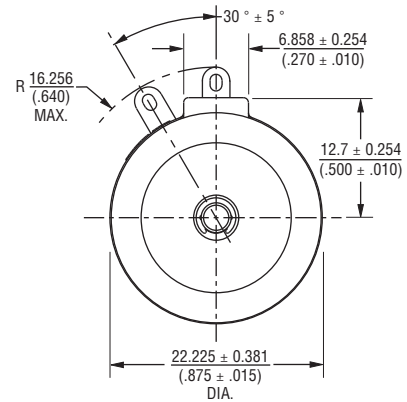
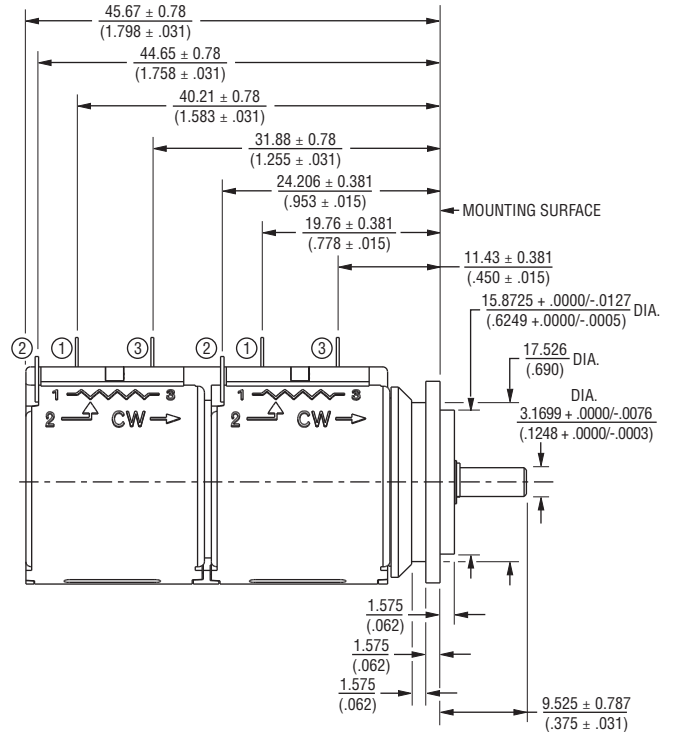

# 3547 - 3-Turn Precision Potentiometer

**BOURNS®**

## Panel Thickness Dimensions

(For Bushing Mount Only)

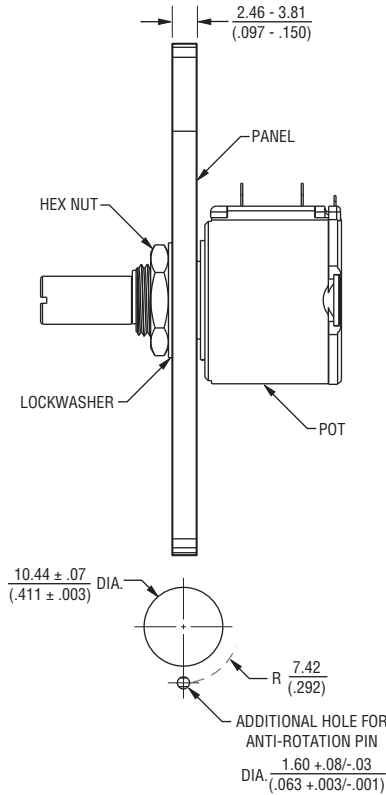

Anti-rotation pin hole is shown at six o'clock position for reference only. The actual location is determined by the customer's application. Refer to the front view of the potentiometer to see the location of the optional A/R pin.

Panel thickness and hole diameters are recommended for best fit. However, customers may adjust the dimensions to suit their specific application.

DIMENSIONS:  $\frac{\text{MM}}{\text{(INCHES)}}$  TOLERANCES:  $\pm \frac{0.127}{(.005)}$

## How To Order

3 5 4 7 S - 2 A A - 1 0 3 / 1 0 3 A

MODEL DESIGNATOR	
Code	Description
3547	3-Turn

ELEMENT TYPE	
Code	Description
H	Hybritron®
S	Wirewound

NO. OF SECTIONS	
Code	Description
1	Single
2	Dual

ANTI-ROTATION LUG*	
Code	Description
A	None
B	180°

\* Anti-rotation lug is not available for servo mount versions.

INDEPENDENT LINEARITY	
Code	Description
A	0.25 %
B	0.20 %

RESISTANCE**		
Code	Element Type	Resolution (%)
102 (1K ohms)	Hybritron®	—
502 (5K ohms)	Hybritron®	—
103 (10K ohms)	Hybritron®	—
201 (200 ohms)	Wirewound	0.110
501 (500 ohms)	Wirewound	0.077
102 (1K ohms)	Wirewound	0.077
202 (2K ohms)	Wirewound	0.062
502 (5K ohms)	Wirewound	0.047
103 (10K ohms)	Wirewound	0.040
203 (20K ohms)	Wirewound	0.031
503 (50K ohms)	Wirewound	0.024

\*\* For Single gang, use only first three digits. For Dual gang, use six digits separated by a "/".

BUSHING MOUNT						
Code	Shaft FMS	Shaft Dia.	Shaft Material	Bushing Dia.	Bushing Material	Slip Clutch
A	13/16 "	1/4 "	Nickel Plated Brass	3/8 "	Brass	N/A
B	20.6 mm	6 mm	Nickel Plated Brass	9 mm	Brass	N/A
C	13/16 "	1/4 "	Stainless Steel	3/8 "	Bronze	N/A
D	20.6 mm	6 mm	Stainless Steel	9 mm	Bronze	N/A
G	13/16 "	1/4 "	Stainless Steel	3/8 "	Bronze	Yes***
H	20.6 mm	6 mm	Stainless Steel	9 mm	Bronze	Yes***

SERVO MOUNT		
Code	Shaft FMS	Shaft Dia.
E	3/8 "	1/8 "

\*\*\* Not available in dual gang version.

**BOURNS®**

Asia-Pacific: Tel: +886-2 2562-4117 • Email: asiacus@bourns.com

EMEA: Tel: +36 88 885 877 • Email: eurocus@bourns.com

The Americas: Tel: +1-951 781-5500 • Email: americus@bourns.com

www.bourns.com

REV. 10/19

"Hybritron" is a registered trademark of Bourns, Inc.

Specifications are subject to change without notice.

Users should verify actual device performance in their specific applications.

The products described herein and this document are subject to specific legal disclaimers as set forth on the last page of this document, and at [www.bourns.com/docs/legal/disclaimer.pdf](http://www.bourns.com/docs/legal/disclaimer.pdf).

This legal disclaimer applies to purchasers and users of Bourns® products manufactured by or on behalf of Bourns, Inc. and its affiliates (collectively, "Bourns").

Unless otherwise expressly indicated in writing, Bourns® products and data sheets relating thereto are subject to change without notice. Users should check for and obtain the latest relevant information and verify that such information is current and complete before placing orders for Bourns® products.

The characteristics and parameters of a Bourns® product set forth in its data sheet are based on laboratory conditions, and statements regarding the suitability of products for certain "typical" applications are based on Bourns' knowledge of typical requirements in generic applications. Bourns assumes that "typical" applications include failsafe/backup features to address critical risks to users and are designed to allow rework of Bourns® product to avoid scrap of a device solely due to malfunctioning Bourns® product. The characteristics and parameters of a Bourns® product in a user application may vary from the data sheet characteristics and parameters due to (i) the combination of the Bourns® product with other components in the user's application, or (ii) the environment of the user application itself. The characteristics and parameters of a Bourns® product also can and do vary in different applications and actual performance may vary over time. Thus, users should always verify the actual performance of the Bourns® product in their specific devices and applications and make their own independent judgments regarding the suitability of Bourns® product and the amount of additional test margin to design into their device or application to compensate for differences between laboratory and real-world conditions.

Unless Bourns has explicitly designated an individual Bourns® product as meeting the requirements of a particular industry standard (e.g., IATF 16949) or a particular qualification (e.g., UL listed or recognized), Bourns is not responsible for any failure of an individual Bourns® product to meet the requirements of such industry standard or particular qualification even if such industry standard or qualification is a "state of art". Users of Bourns® products are responsible for ensuring compliance with safety-related requirements and standards applicable to their devices or applications.

Bourns® products are not recommended, authorized or intended for use in applications where failure or malfunction may result in personal injury, death, or severe property or environmental damage, such as without limitation nuclear, life-critical medical and certain automotive and aviation applications. Except as set forth in the bullet points below or unless expressly and specifically approved in writing on a case-by-case basis by an authorized Bourns' representative, use of any Bourns® products in such unauthorized high-risk applications is at the user's sole risk.

- Bourns considers implantable/invasive devices and devices/procedures designed as life-supporting or life-sustaining by the U.S. Food and Drug Administration or equivalent organizations outside of the United States as "life-critical" medical applications. Bourns expressly identifies those Bourns® standard products that are suitable for use in typical medical applications that are not life-critical in its publication entitled "Bourns Medical Grade Component Guide."
- Bourns expressly identifies those Bourns® standard products that are suitable for use in typical automotive applications associated with any Automate Safety Integrity Level (ASIL) in its publication entitled "Bourns Automotive Grade Component Guide." Bourns' designation of Bourns® product as compliant with the AEC-Q standard does not by itself mean that Bourns has approved such product for use in an automotive application.
- Bourns expressly identifies Bourns® standard products that are suitable for use in the typical aviation applications/systems requiring System Design Assurance Level (RTCA DO-254 DAL) of C, D or E in its publication entitled "Bourns Civilian Aerospace/Aviation Grade Component Guide." Bourns does not test its products for compliance with United States Federal Aviation Administration standards or any other generally equivalent governmental organization standard applicable to products designed or manufactured for use in aviation applications. Use of Bourns® standard components in aviation applications associated with RTCA DO-254 DAL A or B without proper approval noted above shall be at the user's sole risk.
- Bourns will review and authorize on a case-by-case basis the use of Bourns® standard products which are at least AEC-Q compliant in space-related civil applications (rockets, satellites) with a negotiated cross-waiver and indemnity agreement.

The use and level of testing applicable to Bourns® custom products shall be negotiated on a case-by-case basis by Bourns and the user for which such Bourns® custom products are specially designed. Absent a written agreement between Bourns and the user regarding the use and level of such testing, the above provisions applicable to Bourns® standard products shall also apply to such Bourns® custom products.

Use of Bourns® products or Bourns' technology in military/defense applications must be reviewed with Bourns for compliance with applicable export control laws and embargoes. Users shall not sell, transfer, export or re-export (which includes transfers within a country) any Bourns® products or technology or technical data for use in activities which involve the design, development, production, use or stockpiling of nuclear, chemical or biological weapons or missiles, nor shall they use Bourns® products or technology or technical data in any facility which engages in activities relating to such devices. Further, Bourns® products and Bourns' technology and technical data may not under any circumstance be exported or re-exported to countries subject to international sanctions or embargoes. Bourns® products and technology may not, without prior authorization from Bourns and/or the Government of a country where such product/technology is designed and/or manufactured, be resold, transferred, or re-exported (including within the same country) to any party not eligible to receive commodities, software, and technical data originating in such country.

To the maximum extent permitted by applicable law, Bourns disclaims (i) any and all liability for special, punitive, consequential, incidental or indirect damages or lost revenues or lost profits, and (ii) any and all implied warranties (those not based on parameters specified in Bourns' data sheets and/or specifications), including implied warranties of fitness for particular purpose, non-infringement and merchantability.

For your convenience, copies of this Legal Disclaimer Notice with German, Spanish, Japanese, Traditional Chinese and Simplified Chinese bilingual versions are available at:

Web Page: <https://www.bourns.com/legal/disclaimers-terms-and-policies>

PDF: <https://www.bourns.com/docs/Legal/disclaimer.pdf>