

## Features

- RoHS compliant\* versions available
- Overcurrent/lightning protection to TELCORDIA GR-1089 Issue 3
- Typical application is secondary protection on telecom line cards
- UL497A recognition
- Thermal fuse links
- Must be used in conjunction with a solid state primary protector, or a GDT primary protector

# 4A12P-1AH-12R5 - Surge Line Protection Module

### Electrical Characteristics

Resistance Value .....	12.5 ohms
Resistance Tolerance .....	±5 %
TCR .....	100 ppm/°C
Ratio Tolerance .....	±0.5 %
Temperature Range .....	-40 °C to +85 °C

### Physical Characteristics

Body Style .....	Dual In Line SMD - Twin Pack
Substrate Material .....	96 % Alumina
Lead Frame Material .....	Copper, solder coated
Flammability .....	Conforms to UL94V-0
Processability .....	Unit is only suitable for no-clean processing
Convection Reflow .....	Unit will withstand 260 °, 20 seconds
Packaging .....	16 inch diameter reels, 44 mm tape, 250 pcs./reel

### Functional Characteristics @ 25 °C (per Telcordia GR-1089 Issue 3)

#### First Level Lightning Surge -

Resistors will remain within tolerance after testing.

1000 Volts Peak, 100 Amp Peak Current,  
 Max. Rise/Min. Decay Time 10x1000 µs,  
 60 Seconds Between Pulses:  
 Number of Pulses .....25 each resistor each polarity

2500 Volts Peak, 500 Amp Peak Current,  
 Max. Rise/Min. Decay Time 2x10 µs,  
 60 Seconds Between Pulses:  
 Number of Pulses .....10 simultaneous each polarity

Meets Protection Coordination as defined in Telcordia Section 4.6.7.1, Condition A.

#### First Level AC Power Fault -

Resistors will remain within tolerance after testing.

50 Vrms, 0.33 Amp Short Circuit Current:  
 Duration .....15 minutes

100 Vrms, 0.17 Amp Short Circuit Current:  
 Duration .....15 minutes

600 Vrms, 1.00 Amp Short Circuit Current:  
 Duration .....Sixty 1-second pulses

440 Vrms, 2.2 Amp Short Circuit Current:  
 Duration .....Five 2-second pulses,  
 cooling to ambient between pulses

600 Vrms, 3.00 Amp Short Circuit Current:  
 Duration .....Five 1.1-second pulses,  
 cooling to ambient between pulses

### Functional Characteristics @ 25 °C (Continued)

#### Second Level Lightning Surge -

Resistor package must fail safely causing no fire, electrical, or fragmentation hazard.

5000 Volts Peak, 500 Amp Peak Current,  
 Max. Rise/Min. Decay Time 2x10 µs:  
 Number of Pulses .....1 simultaneous each polarity

#### Second Level AC Power Fault -

Resistor package must fail safely causing no fire, electrical, or fragmentation hazard. Device will fail prior to Bussman MDQ 1-6/10 A fuse in series.

100 Vrms, 2.2 Amp Short Circuit Current:  
 Duration .....15 minutes

600 Vrms, 7 Amp Short Circuit Current:  
 Duration .....5 seconds

250 Vrms, 25 Amp Short Circuit Current:  
 Duration .....15 minutes

600 Vrms, 60 Amp Short Circuit Current:  
 Duration .....5 seconds

### Product Dimensions

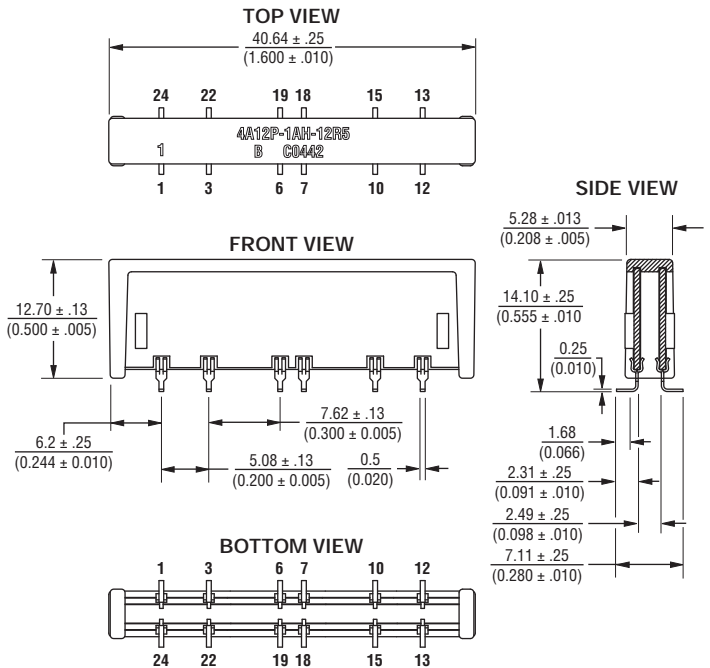

DIMENSIONS:  $\frac{\text{MM}}{\text{(INCHES)}}$



### WARNING Cancer and Reproductive Harm

[www.P65Warnings.ca.gov](http://www.P65Warnings.ca.gov)

\*RoHS Directive 2015/863, Mar 31, 2015 and Annex.

Specifications are subject to change without notice.

Users should verify actual device performance in their specific applications.

The products described herein and this document are subject to specific disclaimers as set forth on the last page of this document, and at [www.bourns.com/legal/disclaimer.pdf](http://www.bourns.com/legal/disclaimer.pdf).

# 4A12P-1AH-12R5 - Surge Line Protection Module

**BOURNS®**

## How To Order

Model \_\_\_\_\_ **4A 12 P - 1AH - 12R5 LF**

(4A = Surface Mount)

Number of Pins \_\_\_\_\_

Physical Configuration \_\_\_\_\_

Electrical Configuration \_\_\_\_\_  
1AH = Custom

Resistance Code \_\_\_\_\_  
12R5 = 12.5 Ohms

RoHS Compliant Option \_\_\_\_\_  
Blank = Standard Product  
LF = RoHS Compliant Product

## Electrical Schematic

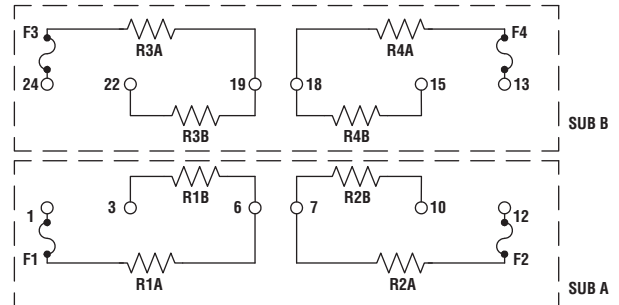

### NOTES:

$R1A + R1B + F1 = 12.5 \text{ OHMS } \pm 5 \%$       $R3A + R3B = 12.5 \text{ OHMS } \pm 5 \%$   
 $R2A + R2B + F2 = 12.5 \text{ OHMS } \pm 5 \%$       $R4A + R4B = 12.5 \text{ OHMS } \pm 5 \%$   
 RATIO MATCH:  $R1 / R2 = 1 \pm 2.5 \%$      RATIO MATCH:  $R3 / R4 = 1 \pm 2.5 \%$   
 CO-PLANARITY = 0.004 INCHES.

**BOURNS®**

Asia-Pacific: Tel: +886-2 2562-4117 • Email: asiacus@bourns.com

EMEA: Tel: +36 88 885 877 • Email: eurocus@bourns.com

The Americas: Tel: +1-951 781-5500 • Email: americus@bourns.com

[www.bourns.com](http://www.bourns.com)

Specifications are subject to change without notice.

Users should verify actual device performance in their specific applications.

The products described herein and this document are subject to specific legal disclaimers as set forth on the last page of this document, and at [www.bourns.com/docs/legal/disclaimer.pdf](http://www.bourns.com/docs/legal/disclaimer.pdf).

# 4A12P-1AH-12R5 - Surge Line Protection Module

**BOURNS®**

## Telcordia GR-1080-CORE Protection Coordination

Protection coordination (Telcordia Technologies Generic Requirements, GR-1089-CORE, Issue 3, October 2002, section 4.6.7.1 protection coordination, page 4-15) is a new test for GR-1089-CORE issue 3 that will be a requirement on January 1, 2006. The equipment using the 4A12P-1AH-12R5 overcurrent line feed resistor (LFR) must be used with either a solid state primary or a primary GDT (5-pin gas discharge tube) such as the Bourns® 2024-31-MSP Protector.

The equipment communication lines will initially be tested at the specified primary voltage protector type using a 10/1000  $\mu$ s generator. A solid state primary will start testing at 400 V where a GDT primary will start at 600 V. If condition A or B defined below is not achieved, the 10/1000 generator voltage,  $V_G$  is increased (in steps of 200 V or interpolated value) to a maximum of 2000 V or until one of the two following criteria is achieved:

- A. The communication lines are stressed to 600 V peak ( $V_P$ ) across the equipment terminals with the GDT specified as a primary.  $V_P$  specification is reduced to 400 A for a solid state primary.

**Note:** Series resistance of the primary protector such as a heat coil resistance is connected between the generator and equipment. This resistance will be effectively added to  $R_{SERIES}$  value when calculating the generator open circuit test voltage.

- B. The peak current ( $I_{PP}$ ) into the equipment terminals exceeds 100 A.

The coordination test requires ten repetitions per polarity. The communication lines will also be tested to metallic and longitudinal procedures to ensure conformance. The equipment fails the coordination requirement if neither A or B is achieved with a maximum generator voltage of 2000 V or the equipment is damaged and does not operate as intended. Figure 1 shows the setup and measurement points for the coordination test.

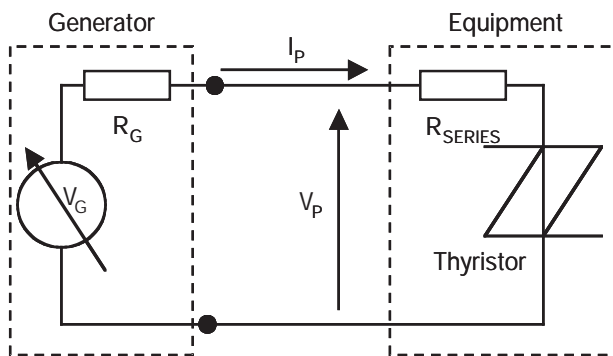

For example, a GDT is defined as the primary protector. The voltage,  $V_P$  will be 600 V and the current through  $R_{SERIES}$  (4A12P-1AH-12R5) will be 48 A (600/12.5). With a generator fictive resistance of 10  $\Omega$ , the generator  $V_G$  should be adjusted to 1080 V to achieve voltage coordination. The resistance of the 4A12P-1AH-12R5 ensures the equipment will voltage coordinate before 100A is achieved.

**Note:** Tolerances of the impulse generator, LFR, measurement, etc. will provide a variation on the actual impulse generator setting.

Figure 1 — Coordination Requirements

## Overvoltage Thyristor Selection

The resistance tolerance of the LFR is  $\pm 5\%$  and therefore the expected maximum current from the generator will be 51 A. To ensure reliable operation of the overvoltage protector, the thyristor should be specified to a 10/1000  $\mu$ s of at least 51 A.

This legal disclaimer applies to purchasers and users of Bourns® products manufactured by or on behalf of Bourns, Inc. and its affiliates (collectively, "Bourns").

Unless otherwise expressly indicated in writing, Bourns® products and data sheets relating thereto are subject to change without notice. Users should check for and obtain the latest relevant information and verify that such information is current and complete before placing orders for Bourns® products.

The characteristics and parameters of a Bourns® product set forth in its data sheet are based on laboratory conditions, and statements regarding the suitability of products for certain "typical" applications are based on Bourns' knowledge of typical requirements in generic applications. Bourns assumes that "typical" applications include failsafe/backup features to address critical risks to users and are designed to allow rework of Bourns® product to avoid scrap of a device solely due to malfunctioning Bourns® product. The characteristics and parameters of a Bourns® product in a user application may vary from the data sheet characteristics and parameters due to (i) the combination of the Bourns® product with other components in the user's application, or (ii) the environment of the user application itself. The characteristics and parameters of a Bourns® product also can and do vary in different applications and actual performance may vary over time. Thus, users should always verify the actual performance of the Bourns® product in their specific devices and applications and make their own independent judgments regarding the suitability of Bourns® product and the amount of additional test margin to design into their device or application to compensate for differences between laboratory and real-world conditions.

Unless Bourns has explicitly designated an individual Bourns® product as meeting the requirements of a particular industry standard (e.g., IATF 16949) or a particular qualification (e.g., UL listed or recognized), Bourns is not responsible for any failure of an individual Bourns® product to meet the requirements of such industry standard or particular qualification even if such industry standard or qualification is a "state of art". Users of Bourns® products are responsible for ensuring compliance with safety-related requirements and standards applicable to their devices or applications.

Bourns® products are not recommended, authorized or intended for use in applications where failure or malfunction may result in personal injury, death, or severe property or environmental damage, such as without limitation nuclear, life-critical medical and certain automotive and aviation applications. Except as set forth in the bullet points below or unless expressly and specifically approved in writing on a case-by-case basis by an authorized Bourns' representative, use of any Bourns® products in such unauthorized high-risk applications is at the user's sole risk.

- Bourns considers implantable/invasive devices and devices/procedures designed as life-supporting or life-sustaining by the U.S. Food and Drug Administration or equivalent organizations outside of the United States as "life-critical" medical applications. Bourns expressly identifies those Bourns® standard products that are suitable for use in typical medical applications that are not life-critical in its publication entitled "Bourns Medical Grade Component Guide."
- Bourns expressly identifies those Bourns® standard products that are suitable for use in typical automotive applications associated with any Automate Safety Integrity Level (ASIL) in its publication entitled "Bourns Automotive Grade Component Guide." Bourns' designation of Bourns® product as compliant with the AEC-Q standard does not by itself mean that Bourns has approved such product for use in an automotive application.
- Bourns expressly identifies Bourns® standard products that are suitable for use in the typical aviation applications/systems requiring System Design Assurance Level (RTCA DO-254 DAL) of C, D or E in its publication entitled "Bourns Civilian Aerospace/Aviation Grade Component Guide." Bourns does not test its products for compliance with United States Federal Aviation Administration standards or any other generally equivalent governmental organization standard applicable to products designed or manufactured for use in aviation applications. Use of Bourns® standard components in aviation applications associated with RTCA DO-254 DAL A or B without proper approval noted above shall be at the user's sole risk.
- Bourns will review and authorize on a case-by-case basis the use of Bourns® standard products which are at least AEC-Q compliant in space-related civil applications (rockets, satellites) with a negotiated cross-waiver and indemnity agreement.

The use and level of testing applicable to Bourns® custom products shall be negotiated on a case-by-case basis by Bourns and the user for which such Bourns® custom products are specially designed. Absent a written agreement between Bourns and the user regarding the use and level of such testing, the above provisions applicable to Bourns® standard products shall also apply to such Bourns® custom products.

Use of Bourns® products or Bourns' technology in military/defense applications must be reviewed with Bourns for compliance with applicable export control laws and embargoes. Users shall not sell, transfer, export or re-export (which includes transfers within a country) any Bourns® products or technology or technical data for use in activities which involve the design, development, production, use or stockpiling of nuclear, chemical or biological weapons or missiles, nor shall they use Bourns® products or technology or technical data in any facility which engages in activities relating to such devices. Further, Bourns® products and Bourns' technology and technical data may not under any circumstance be exported or re-exported to countries subject to international sanctions or embargoes. Bourns® products and technology may not, without prior authorization from Bourns and/or the Government of a country where such product/technology is designed and/or manufactured, be resold, transferred, or re-exported (including within the same country) to any party not eligible to receive commodities, software, and technical data originating in such country.

To the maximum extent permitted by applicable law, Bourns disclaims (i) any and all liability for special, punitive, consequential, incidental or indirect damages or lost revenues or lost profits, and (ii) any and all implied warranties (those not based on parameters specified in Bourns' data sheets and/or specifications), including implied warranties of fitness for particular purpose, non-infringement and merchantability.

For your convenience, copies of this Legal Disclaimer Notice with German, Spanish, Japanese, Traditional Chinese and Simplified Chinese bilingual versions are available at:

Web Page: <https://www.bourns.com/legal/disclaimers-terms-and-policies>

PDF: <https://www.bourns.com/docs/Legal/disclaimer.pdf>