



Features

- Lead free versions available (RoHS compliant*)
- Overvoltage/lightning protection to Bellcore GR-1089 & ITU-T K.20
- Standard “off the shelf” designs
- Typical application is secondary protection on telecom line cards
- Custom versions available, including SMD solutions and fuse technology (contact factory)

4B04B-50X-RC - Surge Line Protection Modules

4B04B-501 (Pair of Matched Resistors)

Product Characteristics

| | |
|--|---------------------|
| Resistance Values | 20 ohms - 100 ohms |
| Resistance Tolerance | ±1 % |
| TCR | 100 ppm/°C |
| Ratio Tolerance | >34 ohms.....±0.5 % |
| | <34 ohms.....±1 % |
| Power Dissipation (per resistor) @ 25 °C | .2 W |
| Temperature Range | -55 °C to +125 °C |

Environmental Characteristics

| | |
|---------------------------------|--|
| TESTS PER MIL-STD-202 | ΔR MAX. |
| Resistance to Solvents | No Marking Deterioration |
| Resistance to Solder Heat | ±0.5 % or 0.5 ohms, whichever is greater |
| Solderability | >95 % Coverage |
| Insulation Resistance | 10 megohms min. (isolated pins) |
| Bias Humidity Test | 50 V/85 % RH/85 °C |

Functional Characteristics

| | |
|------------------------|--|
| Lightning Surge Test | |
| Bellcore Spec GR-1089 | 10 x 1000 μsec1 kV |
| | 2 x 10 μsec2.5 kV |
| ITU-T K.20 | 10 x 700 μsec2 kV |
| Power Cross Test | Per Bellcore spec. |
| | (Vrms applied vary with resistance values) |

Physical Characteristics

| | |
|--|-----------------------|
| Body Style | Open Frame SIP |
| Body Material | 96 % Alumina |
| Lead Frame Material | Copper, solder coated |
| Standard Parts Available Off the Shelf | 50 ohms, 100 ohms |

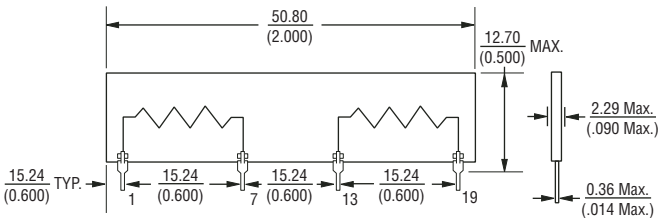

4B04B-502 (Resistor with Thermal Fuse)

Product Characteristics

| | |
|---------------------------------|--------------------------------|
| Resistance Values | 5.6 ohms - 100 ohms |
| Resistance Tolerance | 1 % (optional), 5 % (standard) |
| TCR | .800 ±200 ppm/°C |
| Power Dissipation @ 25 °C | .2 W |
| Temperature Range | -55 °C to +125 °C |

Functional Characteristics

| | |
|------------------------|--|
| Lightning Surge Test | |
| Bellcore Spec GR-1089 | 10 x 1000 μsec1 kV |
| | 2 x 10 μsec2.5 kV |
| Power Cross Test | Per Bellcore spec. |
| | (Vrms applied vary with resistance values) |

Physical Characteristics

| | |
|--|----------------------------|
| Body Style | Open Frame SIP |
| Body Material | 96 % Alumina |
| Lead Frame Material | Copper, solder coated |
| Standard Parts Available Off the Shelf | 5.6 ohms, 10 ohms, 34 ohms |

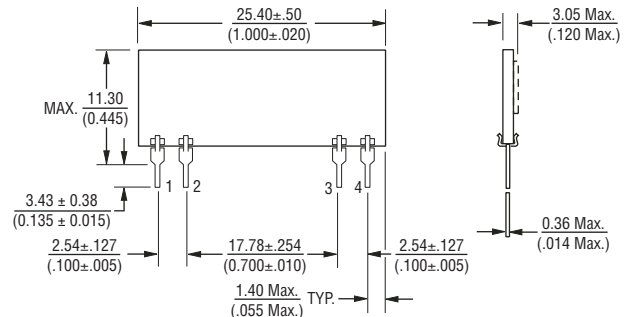

Functional Schematic

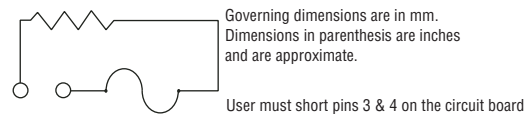

How To Order

Model _____ **4B 04 B - 50X - XXX LF**

(4B = Open Frame)

Number of Pins _____

Physical Configuration _____

Electrical Configuration _____

• 501 = Pair of Matched Resistors

Resistance Code _____

• First 2 digits are significant

• Third digit represents the number of zeros to follow

Lead Free Option _____

Blank = Standard Product

LF = Lead Free / RoHS Compliant Product

How To Order

Model _____ **4B 04 B - 50X - XXX J LF**

(4B = Open Frame)

Number of Pins _____

Physical Configuration _____

Electrical Configuration _____

• 502 = Resistor with Thermal Fuse

Resistance Code _____

• First 2 digits are significant

• Third digit represents the number of zeros to follow

5% Tolerance _____

Lead Free Option _____

Blank = Standard Product

LF = Lead Free / RoHS Compliant Product



WARNING
Cancer and Reproductive Harm
www.P65Warnings.ca.gov

*RoHS Directive 2015/863, Mar 31, 2015 and Annex.
 Specifications are subject to change without notice. Users should verify actual device performance in their specific applications. The products described herein and this document are subject to specific legal disclaimers as set forth on the last page of this document, and at www.bourns.com/docs/legal/disclaimer.pdf

4B04B-50X-RC - Surge Line Protection Modules



General Description

Surge is defined as a high-energy, short-duration pulse caused by lightning or the switching of power loads. In short, a surge can be a transient wave of voltage, current or power. Most of the surge pulse waveforms are unidirectional impulses. Surge waveforms occur in many situations, including computer memory drivers and telecommunication equipment. Standards for various natural surge pulse waveforms in the telecommunication industry are IEC 801-5, ANSI/IEEE C62.41 and Bellcore GR-NWT-001089. Two consequences of inefficient surge protection in a system are (1) permanent damage to internal components, which will require component replacement and (2) temporary instability to a system, resulting in volatile memory loss in a computer or other disruptions.

A typical telecommunication application is shown in Figure 1. There are various protection devices which guard against surge overstresses. Typically, a crowbar is used for primary protection, while current limiters and clamps are used as secondary protection.

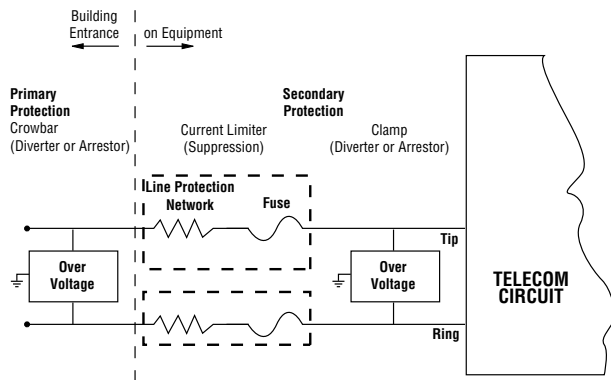

Figure 1. Typical Telecom Application

There are several standard telecommunication waveforms - 10 x 1000 microsecond, 0.5 x 700 micro-second, 10 x 700 microsecond, etc. The definition of a 10 x 1000 microsecond is shown in Figure 2. The first number refers to the voltage rise time while the second numbers indicate the duration. All of these surge pulse waveforms consist of energy levels from 10 to 100 Joules.

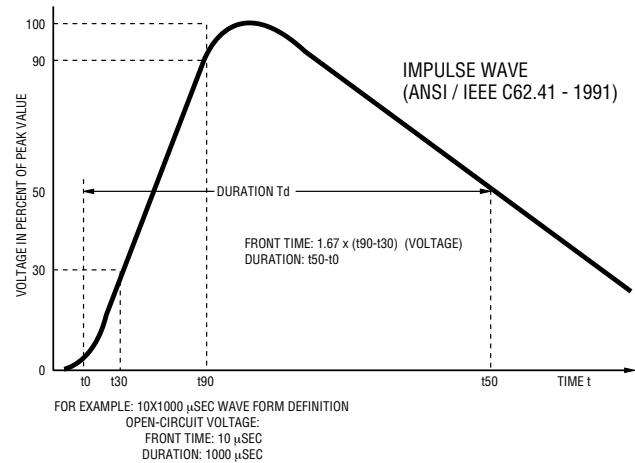
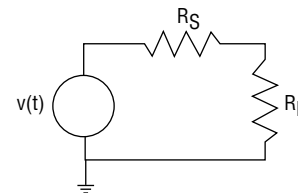

Figure 2. Surge Waveform

Line Protection Networks

Line protection networks are used to dissipate high energy for a short period of time. Figure 3 shows how the amount of energy is dependent on the pulse duration and value of the load resistance. An equation used to determine the amount of energy transferred to the load by the overstress test waveform can be given as follows¹:

$$\text{Energy, } W = \frac{1}{(R_s + R_L)} \cdot \frac{R_L}{(R_s + R_L)} \int_0^{\infty} v^2(t) dt$$



where R_s = source resistance (W)
 R_L = load resistance (W)
 W = energy (Joules)

4B04B-50X-RC - Surge Line Protection Modules

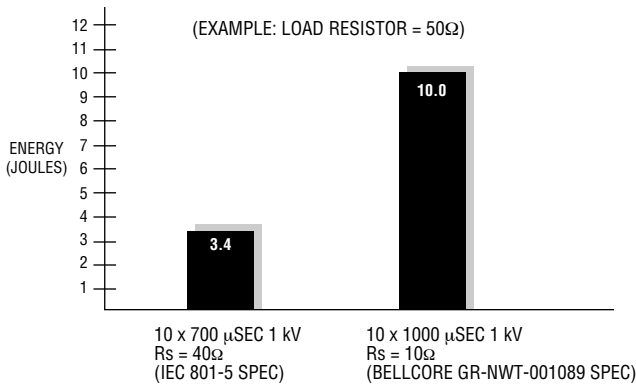

Figure 3. Energy Comparison

Surge protection is necessary in situations where smaller device geometries and higher densities make circuits susceptible to electrical over stress. Applications include instances where faster processing speeds having less inherent filtering make circuits more susceptible to noise. Also, when vulnerable ICs are used in less-controlled environments, circuits can be exposed to extreme electrical conditions.

Common Surge Modes

There are two common surge modes: (1) metallic, i.e., normal, transverse or differential (Figure 4) and (2) longitudinal, i.e., common (Figure 5). In the metallic surge mode, earth or ground is not involved. Both conductors are metal. Surge current flows from tip to ring or ring to tip. The longitudinal surge mode involves a connection in which the wave is applied between one or more lines and ground. The longitudinal surge current flows from tip to ground and ring to ground.

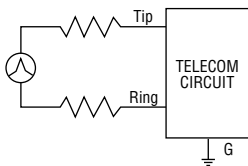

Figure 4. Typical Metallic Application Mode

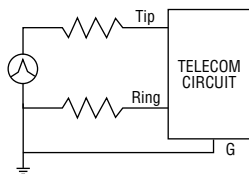

Figure 5. Typical Longitudinal Application Mode

Bourns Line Protection Networks

The Bourns Line Protection Network provides current limiting for telecommunication protection circuits and consists of two high-power surge resistors, which are utilized in the secondary protection block of central office switch systems (Figure 6). This device protects sensitive circuitry from lightning strikes and power cross-conditions by limiting irregular currents through the system.

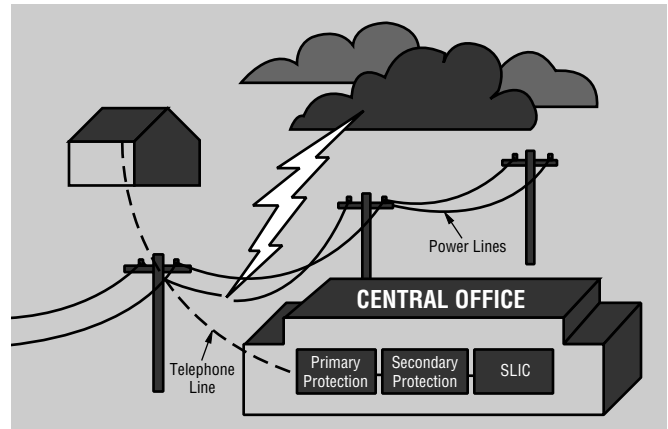

Figure 6. Surge Causes

The line protection network features a resistance range between 50 and 100 ohms, resistors that are able to withstand lightning and power conditions per Bellcore specification GR-NWT-001089, noise reduction through close-ratio matching (\pm percent) between tip and ring resistor pairs and superior material systems created especially for high-power, high-reliability products and applications.

4B04B-50X-RC - Surge Line Protection Modules

BOURNS®

Thick Film Line Protection Network Technology Comparison

| ELEMENTS | OLDER TECHNOLOGY | STATE-OF-THE-ART TECHNOLOGY |
|--|---|--|
| Ceramic thickness | Greater than 0.040 in. | Less than or equal to 0.040 in. |
| Seated height | Greater than 0.5 in. | Less than or equal to 0.5 in. |
| Material and process | Standard thick film material and process | <ul style="list-style-type: none"> • New high power material • Improved processing |
| Temperature coefficient of resistance (TCR) | Greater than 100ppm/°C | Less than 100ppm/°C |
| Tip and ring resistors ratio | 1% | 0.5% or lower |
| Surge test waveforms <ul style="list-style-type: none"> • 100 cycles • 100 cycles • 10 cycles | 10 x 700 μ sec 1 kV 10 x 1000 μ sec 1 kV | 10 x 700 μ sec 1 kV 10 x 1000 μ sec 1 kV 2 x 10 μ sec 2.5 kV |
| Bias humidity temperature 1000 hr. Δ R | 2% or greater | 0.25% or lower |

Thick Film Line Protection Network Construction And Benefits

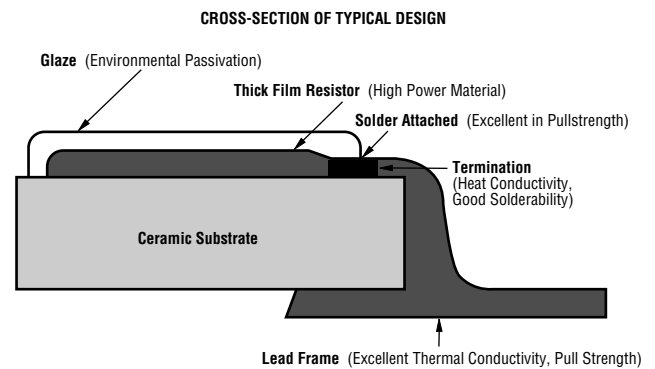

Customer Advantages

The Bourns Thick Film Line Protection Network provides customers with tip and ring resistors on the same component for single placement processing. Customer lead times are reduced because parts are readily available. Bourns is an experienced supplier of state-of-the-art thick film overcurrent protection devices. Bourns also has global design and manufacturing centers for localized service.

Specialty devices are available like surge resistor and standard resistors on the same package, fusible links which are "fail safe" integrated with surge resistors and custom electrical configurations and tolerances. The thick film line protection network also has quick-turn sample times.

REFERENCE: STANDLER, RONALD B., "PROTECTION OF ELECTRONIC CIRCUITS FROM OVERVOLTAGES." PP 89 - 102, 1989.

BOURNS®

Asia-Pacific: Tel: +886-2 2562-4117 • Email: asiacus@bourns.com

EMEA: Tel: +36 88 885 877 • Email: eurocus@bourns.com

The Americas: Tel: +1-951 781-5500 • Email: americus@bourns.com

www.bourns.com

REV. 09/19

Specifications are subject to change without notice.

Users should verify actual device performance in their specific applications.

The products described herein and this document are subject to specific legal disclaimers as set forth on the last page of this document, and at www.bourns.com/docs/legal/disclaimer.pdf.

This legal disclaimer applies to purchasers and users of Bourns® products manufactured by or on behalf of Bourns, Inc. and its affiliates (collectively, "Bourns").

Unless otherwise expressly indicated in writing, Bourns® products and data sheets relating thereto are subject to change without notice. Users should check for and obtain the latest relevant information and verify that such information is current and complete before placing orders for Bourns® products.

The characteristics and parameters of a Bourns® product set forth in its data sheet are based on laboratory conditions, and statements regarding the suitability of products for certain "typical" applications are based on Bourns' knowledge of typical requirements in generic applications. Bourns assumes that "typical" applications include failsafe/backup features to address critical risks to users and are designed to allow rework of Bourns® product to avoid scrap of a device solely due to malfunctioning Bourns® product. The characteristics and parameters of a Bourns® product in a user application may vary from the data sheet characteristics and parameters due to (i) the combination of the Bourns® product with other components in the user's application, or (ii) the environment of the user application itself. The characteristics and parameters of a Bourns® product also can and do vary in different applications and actual performance may vary over time. Thus, users should always verify the actual performance of the Bourns® product in their specific devices and applications and make their own independent judgments regarding the suitability of Bourns® product and the amount of additional test margin to design into their device or application to compensate for differences between laboratory and real-world conditions.

Unless Bourns has explicitly designated an individual Bourns® product as meeting the requirements of a particular industry standard (e.g., IATF 16949) or a particular qualification (e.g., UL listed or recognized), Bourns is not responsible for any failure of an individual Bourns® product to meet the requirements of such industry standard or particular qualification even if such industry standard or qualification is a "state of art". Users of Bourns® products are responsible for ensuring compliance with safety-related requirements and standards applicable to their devices or applications.

Bourns® products are not recommended, authorized or intended for use in applications where failure or malfunction may result in personal injury, death, or severe property or environmental damage, such as without limitation nuclear, life-critical medical and certain automotive and aviation applications. Except as set forth in the bullet points below or unless expressly and specifically approved in writing on a case-by-case basis by an authorized Bourns' representative, use of any Bourns® products in such unauthorized high-risk applications is at the user's sole risk.

- Bourns considers implantable/invasive devices and devices/procedures designed as life-supporting or life-sustaining by the U.S. Food and Drug Administration or equivalent organizations outside of the United States as "life-critical" medical applications. Bourns expressly identifies those Bourns® standard products that are suitable for use in typical medical applications that are not life-critical in its publication entitled "Bourns Medical Grade Component Guide."
- Bourns expressly identifies those Bourns® standard products that are suitable for use in typical automotive applications associated with any Automate Safety Integrity Level (ASIL) in its publication entitled "Bourns Automotive Grade Component Guide." Bourns' designation of Bourns® product as compliant with the AEC-Q standard does not by itself mean that Bourns has approved such product for use in an automotive application.
- Bourns expressly identifies Bourns® standard products that are suitable for use in the typical aviation applications/systems requiring System Design Assurance Level (RTCA DO-254 DAL) of C, D or E in its publication entitled "Bourns Civilian Aerospace/Aviation Grade Component Guide." Bourns does not test its products for compliance with United States Federal Aviation Administration standards or any other generally equivalent governmental organization standard applicable to products designed or manufactured for use in aviation applications. Use of Bourns® standard components in aviation applications associated with RTCA DO-254 DAL A or B without proper approval noted above shall be at the user's sole risk.
- Bourns will review and authorize on a case-by-case basis the use of Bourns® standard products which are at least AEC-Q compliant in space-related civil applications (rockets, satellites) with a negotiated cross-waiver and indemnity agreement.

The use and level of testing applicable to Bourns® custom products shall be negotiated on a case-by-case basis by Bourns and the user for which such Bourns® custom products are specially designed. Absent a written agreement between Bourns and the user regarding the use and level of such testing, the above provisions applicable to Bourns® standard products shall also apply to such Bourns® custom products.

Use of Bourns® products or Bourns' technology in military/defense applications must be reviewed with Bourns for compliance with applicable export control laws and embargoes. Users shall not sell, transfer, export or re-export (which includes transfers within a country) any Bourns® products or technology or technical data for use in activities which involve the design, development, production, use or stockpiling of nuclear, chemical or biological weapons or missiles, nor shall they use Bourns® products or technology or technical data in any facility which engages in activities relating to such devices. Further, Bourns® products and Bourns' technology and technical data may not under any circumstance be exported or re-exported to countries subject to international sanctions or embargoes. Bourns® products and technology may not, without prior authorization from Bourns and/or the Government of a country where such product/technology is designed and/or manufactured, be resold, transferred, or re-exported (including within the same country) to any party not eligible to receive commodities, software, and technical data originating in such country.

To the maximum extent permitted by applicable law, Bourns disclaims (i) any and all liability for special, punitive, consequential, incidental or indirect damages or lost revenues or lost profits, and (ii) any and all implied warranties (those not based on parameters specified in Bourns' data sheets and/or specifications), including implied warranties of fitness for particular purpose, non-infringement and merchantability.

For your convenience, copies of this Legal Disclaimer Notice with German, Spanish, Japanese, Traditional Chinese and Simplified Chinese bilingual versions are available at:

Web Page: <https://www.bourns.com/legal/disclaimers-terms-and-policies>

PDF: <https://www.bourns.com/docs/Legal/disclaimer.pdf>