

Features

- RoHS compliant*
- Push-pull switch
- Linear and audio tapers
- PC board and bushing mount
- Splash seal
- Metal bushing and shaft

Applications

- Test and measurement equipment
- Communications equipment
- Medical diagnostic equipment
- Professional audio equipment

54 – 1/2" (12.5 mm) Panel Control w/Push-Pull Switch

Electrical Characteristics¹

Standard Resistance Range	
Linear.....	1K to 500K ohms
Audio.....	1K to 500K ohms
Total Resistance Tolerance	
B & D Tapers.....	±20 %
E & S Tapers.....	±10 %
Independent Linearity.....	±5 %
Absolute Minimum Resistance.....	2 ohms maximum
Effective Electrical Angle.....	270 ° ±5
Contact Resistance Variation.....	±2 %
Dielectric Withstanding Voltage (MIL-STD-202 – Method 301)	
Sea Level.....	1,500 VAC minimum
70,000.....	500 VAC minimum
Insulation Resistance.....	1,000 megohms minimum
Power Rating At 70 °C (Derate To 0 At 125 °C)	
(Voltage Limited By Power Dissipation or 350 VAC, Whichever Is Less)	
Linear Tapers.....	0.5 watt
Audio Tapers.....	0.25 watt
Theoretical Resolution.....	Essentially infinite

Additional Information

Click these links for more information:



Environmental Characteristics¹

Operating Temperature Range.....	+1 °C to +125 °C
Storage Temperature Range.....	-55 °C to +125 °C
Temperature Coefficient Over Storage Temperature Range.....	±1,000 ppm/°C
Vibration.....	15 G
Total Resistance Shift.....	±2 % maximum
Voltage Ratio Shift.....	±5 % maximum
Shock.....	20 G
Total Resistance Shift.....	+2 % maximum
Voltage Ratio Shift.....	±5 % maximum
Load Life.....	1,000 hours
Total Resistance Shift.....	±10 % TRS maximum
Rotational Life (No Load).....	50,000 cycles
Total Resistance Shift.....	±10 % TRS maximum
Contact Resistance Variation.....	±2 %
Moisture Resistance (MIL-STD-202, Method 103, Condition B)	
B & E.....	±10 % TRS
D & S.....	±20 % TRS
IP Rating	
Entire Unit.....	IP64
Shaft/Bushing.....	IP65

Mechanical Characteristics

Stop Strength.....	39.5 N-cm (3.5 lb.-in.)
Mechanical Angle.....	290 ° ±5 °
Torque	
Starting/Running.....	0.2 to 1.3 N-cm (0.25 to 2.0 oz.-in.)
Mounting (Torque on Bushing).....	1.7 to 2.0 N-m (15 to 18 lb.-in.)
Weight.....	10 grams
Terminals.....	PC pin
Soldering Condition.....	Recommended hand soldering using Sn95/Ag5 no clean solder, 0.025" wire diameter. Maximum temperature 399 °C (750 °F) for 3 seconds. No wash process to be used with no clean flux. Part can be wave soldered at 260 °C (500 °F) for 5 seconds, no wash process with no clean flux.
Marking.....	Manufacturer's trademark, part number, resistance value and date code.
Ganging (Multiple Section Potentiometers).....	Inquire for availability, minimum order quantity and price.
Hardware.....	Locking bushing versions are shipped with one additional locking nut (Bushing A: H-37-2 & H-38-2; Bushing C: H-37-1 & H-38-1)

¹Electrical specifications tested at 200 RPM, at room ambient: +25 °C nominal.



WARNING
Cancer and Reproductive Harm
www.P65Warnings.ca.gov

*RoHS Directive 2015/863, Mar 31, 2015 and Annex.
Specifications are subject to change without notice. Users should verify actual device performance in their specific applications. The products described herein and this document are subject to specific legal disclaimers as set forth on the last page of this document, and at www.bourns.com/docs/legal/disclaimer.pdf.

54 – 1/2" (12.5 mm) Panel Control w/Push-Pull Switch

BOURNS®

Initial Electrical Characteristics - Switch

Switch Type	DPDT (Break before make)
Power Rating (Resistive Load)	0.25 A @ 30 VDC
Dielectric Withstanding Voltage (MIL-STD-202, Method 301)	
Sea Level	1000 VAC minimum
Insulation Resistance	1500 megohms minimum
Contact Resistance	100 milliohms maximum
Actuating Stroke	0.41 cm (0.16 in.) maximum

Environmental Characteristics¹

Vibration	8 G
Contact Resistance	100 milliohms maximum
Contact Bounce	0.1 milliseconds maximum
Shock	20 G
Contact Resistance	100 milliohms maximum
Contact Bounce	0.1 milliseconds maximum
Switch Life @ Rated Power	15,000 actuations
Switch Actuating Force	0.45 kg (1.0 lb) minimum
Contact Resistance	100 milliohms maximum
Moisture Resistance (MIL-STD-202, Method 103, Condition B)	
Contact Resistance	100 milliohms maximum
Insulation Resistance (After 24 Hours @ Room Temperature - 500 VDC)	100 megohms minimum

¹Electrical specifications tested at 200 RPM at room ambient: +25 °C nominal.

Switch Configurations (Shown in Pulled Position)

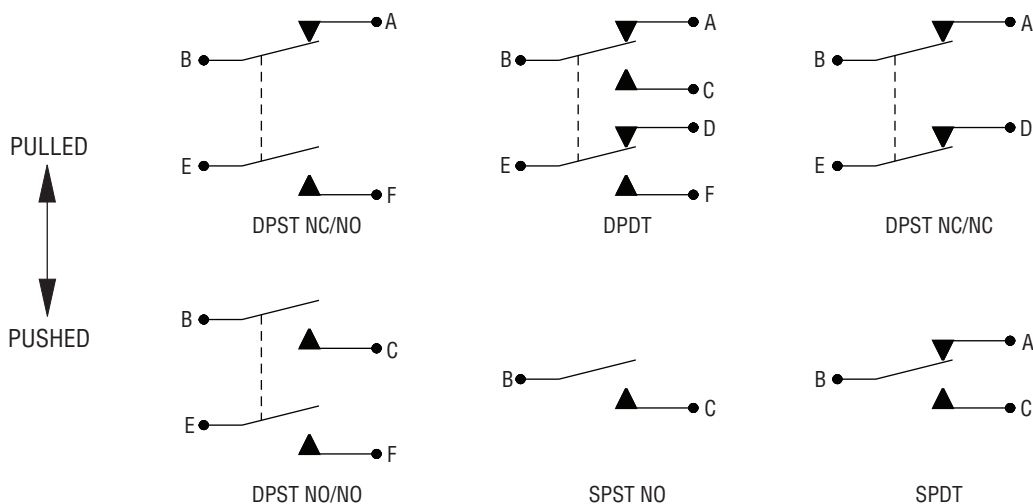

Specifications are subject to change without notice.

Users should verify actual device performance in their specific applications.

The products described herein and this document are subject to specific legal disclaimers as set forth on the last page of this document, and at www.bourns.com/docs/legal/disclaimer.pdf.

54 – 1/2" (12.5 mm) Panel Control w/Push-Pull Switch



Product Dimensions

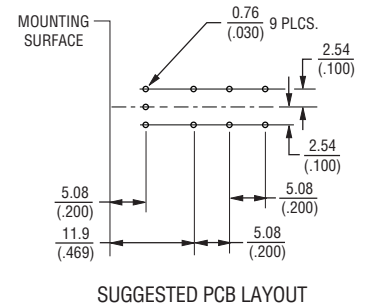
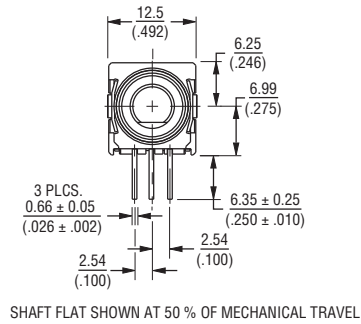
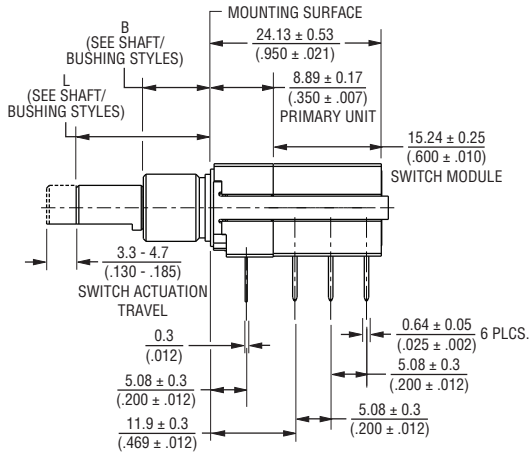

PACKAGE DIMENSIONS WITH FRONT AND REAR PCB MOUNTING BRACKET

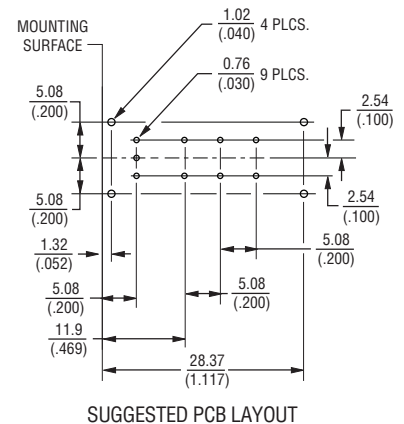
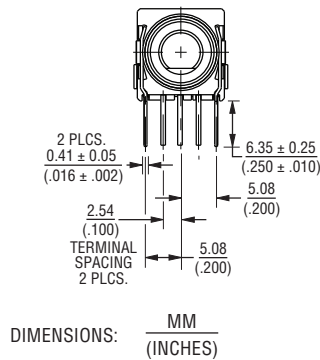
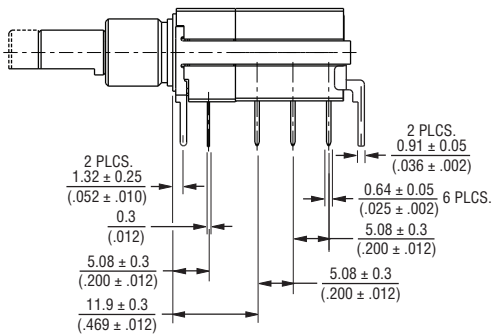

Anti-Rotation Lug

(Style "A", 90° CW Shown)

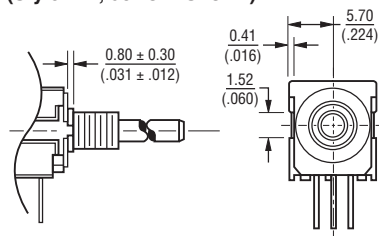

FOR TOLERANCES SHOWN: .XX = ± $\frac{.25}{.010}$
 .XXX = ± $\frac{.13}{.005}$
 SHAFT DIMENSIONS = ± $\frac{.80}{(1/32)}$

Terminal Layout

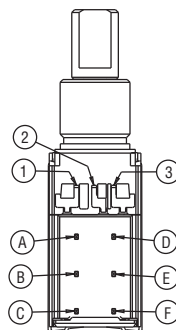

Electrical Schematic

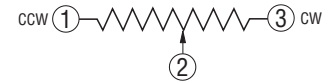

Suggested Panel Layouts

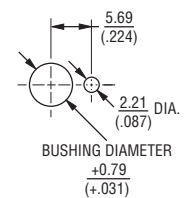

Specifications are subject to change without notice.

Users should verify actual device performance in their specific applications.

The products described herein and this document are subject to specific legal disclaimers as set forth on the last page of this document, and at www.bourns.com/docs/legal/disclaimer.pdf.

54 – 1/2" (12.5 mm) Panel Control w/Push-Pull Switch

BOURNS®

Hardware

LOCKWASHER H-37-1

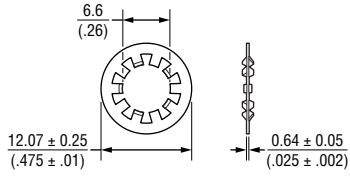

LOCKWASHER H-37-2

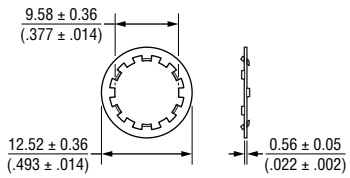

NUT H-38-1

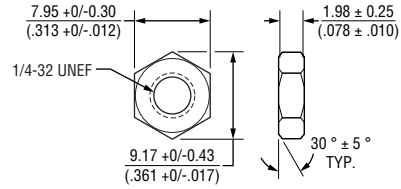

NUT H-38-2

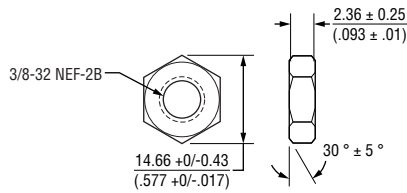

DIMENSIONS: $\frac{\text{MM}}{\text{(INCHES)}}$

Date Code Description

YY WW M

M = COUNTRY OF MANUFACTURE (MEXICO)
 WW = WEEK NUMBER
 YY = LAST TWO DIGITS OF YEAR MANUFACTURED

Specifications are subject to change without notice.

Users should verify actual device performance in their specific applications.

The products described herein and this document are subject to specific legal disclaimers as set forth on the last page of this document, and at www.bourns.com/docs/legal/disclaimer.pdf.

54 – 1/2" (12.5 mm) Panel Control w/Push-Pull Switch



Shaft/Bushing Styles

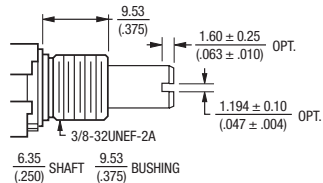

A Style Bushing

STD. LENGTH 'L'
.750 (19.05)
.875 (22.23)

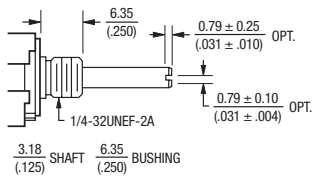

C Style Bushing

STD. LENGTH 'L'
.750 (19.05)
.875 (22.23)

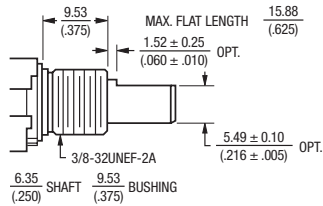

A Style Bushing - Flatted Shaft

STD. LENGTH 'L'
.750 (19.05)
.875 (22.23)

DIMENSIONS: $\frac{\text{MM}}{\text{(INCHES)}}$

How To Order

54 A A D - C 28 - B 15 / P50 L

ANTI-ROTATION LUG / BRACKET OPTION	
Code	Description
A	AR Lug 90° CW
D	No AR Lug or Bracket
L	Front Bracket
N	Front and Rear Bracket

RoHS IDENTIFIER	
Code	Description
L	Compliant

SWITCH OPTION	
Code	Description
P50	DPDT

NO. OF SECTIONS	
Code	Description
A	Single plus Switch

RESISTANCE CODES	
Code	Value in Ohms
10	1K
13	5K
15	10K
18	50K
20	100K
22	250K
23	500K

BUSHING DESIGNATOR	
Code	Description
A	3/8" D x 3/8" L Threaded
C	1/4" D x 1/4" L Threaded

MODEL	
Code	Description
54	PC Terminals w/Push-Pull Switch

ELEMENT TAPER TYPE/TOLERANCE	
Code	Description
B	Linear CP ±20 %
E	Linear CP ±10 %
D	CW Audio CP ±20 %
S	CW Audio CP ±10 %

SHAFT LENGTH DESIGNATOR	
Code	Description
24	3/4" FMS Long
28	7/8" FMS Long

SHAFT STYLE		AVAILABLE ONLY WITH BUSHING
Code	Description	Code
B	1/4" D Slotted End	A
C	1/4" D Flatted End	A
E	1/8" D Slotted End	C

Boldface features are Bourns standard options. All others are available with higher minimum order quantities.



Asia-Pacific: Tel: +886-2 2562-4117 • Email: asiacus@bourns.com
 Europe: Tel: +36 88 885 877 • Email: eurocus@bourns.com
 Mexico: Tel: +52 614 478 0400 • Email: mexicus@bourns.com
 The Americas: Tel: +1-951 781-5500 • Email: americus@bourns.com
www.bourns.com

REV. 04/25

Specifications are subject to change without notice.

Users should verify actual device performance in their specific applications.

The products described herein and this document are subject to specific legal disclaimers as set forth on the last page of this document, and at www.bourns.com/docs/legal/disclaimer.pdf.

This legal disclaimer applies to purchasers and users of Bourns® products manufactured by or on behalf of Bourns, Inc. and its affiliates (collectively, "Bourns").

Unless otherwise expressly indicated in writing, Bourns® products and data sheets relating thereto are subject to change without notice. Users should check for and obtain the latest relevant information and verify that such information is current and complete before placing orders for Bourns® products.

The characteristics and parameters of a Bourns® product set forth in its data sheet are based on laboratory conditions, and statements regarding the suitability of products for certain "typical" applications are based on Bourns' knowledge of typical requirements in generic applications. Bourns assumes that "typical" applications include failsafe/backup features to address critical risks to users and are designed to allow rework of Bourns® product to avoid scrap of a device solely due to malfunctioning Bourns® product. The characteristics and parameters of a Bourns® product in a user application may vary from the data sheet characteristics and parameters due to (i) the combination of the Bourns® product with other components in the user's application, or (ii) the environment of the user application itself. The characteristics and parameters of a Bourns® product also can and do vary in different applications and actual performance may vary over time. Thus, users should always verify the actual performance of the Bourns® product in their specific devices and applications and make their own independent judgments regarding the suitability of Bourns® product and the amount of additional test margin to design into their device or application to compensate for differences between laboratory and real-world conditions.

Unless Bourns has explicitly designated an individual Bourns® product as meeting the requirements of a particular industry standard (e.g., IATF 16949) or a particular qualification (e.g., UL listed or recognized), Bourns is not responsible for any failure of an individual Bourns® product to meet the requirements of such industry standard or particular qualification even if such industry standard or qualification is a "state of art". Users of Bourns® products are responsible for ensuring compliance with safety-related requirements and standards applicable to their devices or applications.

Bourns® products are not recommended, authorized or intended for use in applications where failure or malfunction may result in personal injury, death, or severe property or environmental damage, such as without limitation nuclear, life-critical medical and certain automotive and aviation applications. Except as set forth in the bullet points below or unless expressly and specifically approved in writing on a case-by-case basis by an authorized Bourns' representative, use of any Bourns® products in such unauthorized high-risk applications is at the user's sole risk.

- Bourns considers implantable/invasive devices and devices/procedures designed as life-supporting or life-sustaining by the U.S. Food and Drug Administration or equivalent organizations outside of the United States as "life-critical" medical applications. Bourns expressly identifies those Bourns® standard products that are suitable for use in typical medical applications that are not life-critical in its publication entitled "Bourns Medical Grade Component Guide."
- Bourns expressly identifies those Bourns® standard products that are suitable for use in typical automotive applications associated with any Automate Safety Integrity Level (ASIL) in its publication entitled "Bourns Automotive Grade Component Guide." Bourns' designation of Bourns® product as compliant with the AEC-Q standard does not by itself mean that Bourns has approved such product for use in an automotive application.
- Bourns expressly identifies Bourns® standard products that are suitable for use in the typical aviation applications/systems requiring System Design Assurance Level (RTCA DO-254 DAL) of C, D or E in its publication entitled "Bourns Civilian Aerospace/Aviation Grade Component Guide." Bourns does not test its products for compliance with United States Federal Aviation Administration standards or any other generally equivalent governmental organization standard applicable to products designed or manufactured for use in aviation applications. Use of Bourns® standard components in aviation applications associated with RTCA DO-254 DAL A or B without proper approval noted above shall be at the user's sole risk.
- Bourns will review and authorize on a case-by-case basis the use of Bourns® standard products which are at least AEC-Q compliant in space-related civil applications (rockets, satellites) with a negotiated cross-waiver and indemnity agreement.

The use and level of testing applicable to Bourns® custom products shall be negotiated on a case-by-case basis by Bourns and the user for which such Bourns® custom products are specially designed. Absent a written agreement between Bourns and the user regarding the use and level of such testing, the above provisions applicable to Bourns® standard products shall also apply to such Bourns® custom products.

Use of Bourns® products or Bourns' technology in military/defense applications must be reviewed with Bourns for compliance with applicable export control laws and embargoes. Users shall not sell, transfer, export or re-export (which includes transfers within a country) any Bourns® products or technology or technical data for use in activities which involve the design, development, production, use or stockpiling of nuclear, chemical or biological weapons or missiles, nor shall they use Bourns® products or technology or technical data in any facility which engages in activities relating to such devices. Further, Bourns® products and Bourns' technology and technical data may not under any circumstance be exported or re-exported to countries subject to international sanctions or embargoes. Bourns® products and technology may not, without prior authorization from Bourns and/or the Government of a country where such product/technology is designed and/or manufactured, be resold, transferred, or re-exported (including within the same country) to any party not eligible to receive commodities, software, and technical data originating in such country.

To the maximum extent permitted by applicable law, Bourns disclaims (i) any and all liability for special, punitive, consequential, incidental or indirect damages or lost revenues or lost profits, and (ii) any and all implied warranties (those not based on parameters specified in Bourns' data sheets and/or specifications), including implied warranties of fitness for particular purpose, non-infringement and merchantability.

For your convenience, copies of this Legal Disclaimer Notice with German, Spanish, Japanese, Traditional Chinese and Simplified Chinese bilingual versions are available at:

Web Page: <https://www.bourns.com/legal/disclaimers-terms-and-policies>

PDF: <https://www.bourns.com/docs/Legal/disclaimer.pdf>