



Features

- Formerly a **KEKOVARICON** product
- Six model sizes equivalent to standard disc varistors
- Smaller nominal dimensions than disc varistors
- Broad range of current and energy handling capabilities

- +85 °C Continuous operating temperature
- Low clamping voltage
- Available with straight or crimped leads
- Available in tape and reel packaging for automatic pick-and-place
- RoHS compliant*

SV Series – Special Medium Voltage Varistors

General Information

The SV series is a series of lead style epoxy coated square or rectangular shaped varistors with an AC operating voltage ranging from 60 V to 550 V. This series offers both standard and custom options.

The standard offering consists of square shaped varistors with extremely high current and energy capabilities and a low clamping voltage, providing an increased level of protection for the transients expected in telecommunication and AC power networks. Compared to electrically equivalent disc varistors, SV varistors are produced with smaller nominal dimensions.

In addition to the standard offering, customers are offered the option to design their own customized varistor to suit their specific application needs. Parameters free to be chosen are: non-standard DC/AC operating voltage, leakage current, clamping voltage, maximum surge current, energy absorption level, maximum dissipation power as well as shape - the dimensions being the function of required electrical parameters and vice-versa.

Summary of Custom Varistor Options

- DC operating voltage range (V_{dc}): 85 V to 745 V (up to 1300 V for customized products)
- AC operating voltage range (V_{rms}): 60 V to 550 V (up to 1000 V for customized products)
- Six standard sizes available; other customized sizes available upon request
- Broad range of current and energy handling capabilities
- +85 °C Continuous operating temperature
- Available electrical parameter options: AC/DC operating voltage, leakage current, clamping voltage, maximum surge current, energy absorption level, maximum dissipation power and threshold voltage temperature coefficient
- Available in tape and reel packaging for automatic pick-and-place
- Model SVxxxK20 with $I_{max} = 1 \times 15 \text{ kA} @ 8/20 \mu\text{s}$ is available upon request
- Model SVxxxK23 with $I_{max} = 1 \times 20 \text{ kA} @ 8/20 \mu\text{s}$ is available upon request

Varistor Symbol

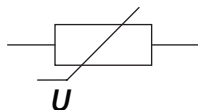

WARNING Cancer and Reproductive Harm - www.P65Warnings.ca.gov

*RoHS Directive 2015/863, Mar 31, 2015 and Annex. Specifications are subject to change without notice.

Users should verify actual device performance in their specific applications.

The products described herein and this document are subject to specific legal disclaimers as set forth on the last page of this document, and at www.bourns.com/docs/legal/disclaimer.pdf.

Additional Information

Click these links for more information:



Agency Recognition

Standard	UL 1449
File Number	E313168**

**Not all rated voltages are UL recognized; check the file for details.

Standard	IEC 61051-1, IEC61051-2, IEC 61051-2-2
File Number	J 50590630 (TÜV)***

*** The following models are recognized with deviated parameters:

SV 300 K 7: D (Max.) = 8.4 mm
 SV 550 K 14: h (Max) = 20.35 mm
 SV 550 K 20: $V_c = 1500 \text{ V}$

Index

Features	1
General Information	1
Varistor Symbol	1
Summary of Custom Varistor Options	1
Absolute Maximum Ratings	2
Device Ratings	2-4
Product Dimensions	5-7
Full Custom Parameter Designed Medium Voltage Varistors	8
General Technical Data	8
How to Order	8
Typical Part Marking	8
Pulse Rating Curves	9-11
Packaging Drawings	12
Packaging Specifications	13-14
Assembly / Soldering Recommendations for Through-Hole Components	15
Reliability Testing Procedures	16-17
Terminology	18
Legal Disclaimer	19

SV Series – Special Medium Voltage Varistors

BOURNS®

Absolute Maximum Ratings

Parameter	Standard Types	Units	Custom Designed Types	Units
Continuous:				
Steady State Applied Voltage				
DC Voltage Range (V_{dc})	85 to 745	V	85 to 1300	V
AC Voltage Range (V_{rms})	60 to 550	V	60 to 1000	V
Transient:				
Peak Single Pulse Surge Current, 8/20 μ s Waveform (I_{max})	600 to 15,000	A	> 5500	A/cm ²
Single Pulse Surge Energy, 10/1000 μ s Waveform (W_{max})	4 to 815	J	> 400	J/cm ²
Operating Ambient Temperature	-40 to +85	°C	-40 to +125	°C
Storage Temperature Range	-40 to +125	°C	-40 to +125	°C
Threshold Voltage Temperature Coefficient	< +0.05	%/°C	< +0.05	%/°C
Insulation Resistance	> 1	G Ω	> 1	G Ω
Isolation Voltage Capability	> 2.5	kV	> 2.5	kV
Response Time	< 25	ns	< 2.5	μ s
Climatic Category	40 / 85 / 56		40 / 125 / 56	

* Valid for epoxy coated components

Device Ratings

Model	V_{rms}	V_{dc}	V_n @ 1 mA	V_c	I_c	W_{max} 10/1000 μ s	P max.	I_{max}^* 8/20 μ s	C Typ. @ 1 kHz
	V	V	V	V	A	J	W	A	pF
SV 60 K 5	60	85	100	155	5	4	0.1	600	370
SV 60 K 7	60	85	100	155	10	9	0.25	1750	900
SV 60 K 10	60	85	100	155	25	20	0.4	3500	1380
SV 60 K 14	60	85	100	155	50	42	0.6	8000	2300
SV 60 K 20	60	85	100	155	100	89	1	12000	3400
SV 75 K 5	75	100	120	190	5	5	0.1	600	300
SV 75 K 7	75	100	120	190	10	11	0.25	1750	720
SV 75 K 10	75	100	120	190	25	26	0.4	3500	1080
SV 75 K 14	75	100	120	190	50	51	0.6	8000	1850
SV 75 K 20	75	100	120	190	100	101	1	12000	3100
SV 95 K 5	95	125	150	240	5	7	0.1	600	240
SV 95 K 7	95	125	150	240	10	14	0.25	1750	580
SV 95 K 10	95	125	150	240	25	31	0.4	3500	870
SV 95 K 14	95	125	150	240	50	64	0.6	8000	1480
SV 95 K 20	95	125	150	240	100	133	1	12000	2700
SV 115 K 5	115	150	180	290	5	8	0.1	600	200
SV 115 K 7	115	150	180	290	10	16	0.25	1750	480
SV 115 K 10	115	150	180	290	25	37	0.4	3500	750
SV 115 K 14	115	150	180	290	50	78	0.6	8000	1230
SV 115 K 20	115	150	180	290	100	147	1	12000	2200

Model SVxxxK 20 with $I_{max} = 1 \times 15 \text{ kA} @ 8/20 \mu\text{s}$ available upon request.

Continued on Next Page

Model SVxxxK 23 with $I_{max} = 1 \times 20 \text{ kA} @ 8/20 \mu\text{s}$ available upon request.

Specifications are subject to change without notice.

Users should verify actual device performance in their specific applications.

The products described herein and this document are subject to specific legal disclaimers as set forth on the last page of this document, and at www.bourns.com/docs/legal/disclaimer.pdf.

SV Series – Special Medium Voltage Varistors

BOURNS®

Device Ratings (Continued)

Model	V _{rms}	V _{dc}	V _n @ 1 mA	V _c	I _c	W _{max} 10/1000 μs	P max.	I _{max} * 8/20 μs	C Typ. @ 1 kHz
	V	V	V	V	A	J	W	A	pF
SV 130 K 5	130	170	205	320	5	9	0.1	600	180
SV 130 K 7	130	170	205	320	10	19	0.25	1750	430
SV 130 K 10	130	170	205	320	25	42	0.4	3500	670
SV 130 K 14	130	170	205	320	50	85	0.6	8000	1100
SV 130 K 20	130	170	205	320	100	177	1	12000	2150
SV 130 K 23	130	170	205	320	100	222	1	15000	3390
SV 140 K 5	140	180	220	340	5	9	0.1	600	170
SV 140 K 7	140	180	220	340	10	22	0.25	1750	400
SV 140 K 10	140	180	220	340	25	46	0.4	3500	620
SV 140 K 14	140	180	220	340	50	94	0.6	8000	1020
SV 140 K 20	140	180	220	340	100	196	1	12000	1900
SV 140 K 23	140	180	220	340	100	247	1	15000	3340
SV 150 K 5	150	200	240	360	5	11	0.1	600	160
SV 150 K 7	150	200	240	360	10	23	0.25	1750	380
SV 150 K 10	150	200	240	360	25	51	0.4	3500	590
SV 150 K 14	150	200	240	360	50	101	0.6	8000	690
SV 150 K 20	150	200	240	360	100	213	1	12000	1740
SV 150 K 23	150	200	240	360	100	270	1	15000	3050
SV 175 K 5	175	225	270	420	5	11	0.1	600	140
SV 175 K 7	175	225	270	420	10	26	0.25	1750	330
SV 175 K 10	175	225	270	420	25	58	0.4	3500	500
SV 175 K 14	175	225	270	420	50	119	0.6	8000	830
SV 175 K 20	175	225	270	420	100	241	1	12000	1630
SV 175 K 23	175	225	270	420	100	305	1	15000	2870
SV 230 K 5	230	300	360	550	5	16	0.1	600	110
SV 230 K 7	230	300	360	550	10	35	0.25	1750	250
SV 230 K 10	230	300	360	550	25	78	0.4	3500	400
SV 230 K 14	230	300	360	550	50	157	0.6	8000	650
SV 230 K 20	230	300	360	550	100	322	1	12000	1220
SV 230 K 23	230	300	360	550	100	407	1	15000	2020
SV 250 K 5	250	320	390	590	5	17	0.1	600	100
SV 250 K 7	250	320	390	590	10	38	0.25	1750	240
SV 250 K 10	250	320	390	590	25	85	0.4	3500	370
SV 250 K 14	250	320	390	590	50	169	0.6	8000	600
SV 250 K 20	250	320	390	590	100	345	1	12000	1130
SV 250 K 23	250	320	390	590	100	437	1	15000	1980

Model SVxxxK 20 with I_{max} = 1 x 15 kA @ 8/20 μs available upon request.

Continued on Next Page

Model SVxxxK 23 with I_{max} = 1 x 20 kA @ 8/20 μs available upon request.

Specifications are subject to change without notice.

Users should verify actual device performance in their specific applications.

The products described herein and this document are subject to specific legal disclaimers as set forth on the last page of this document, and at www.bourns.com/docs/legal/disclaimer.pdf.

SV Series – Special Medium Voltage Varistors

BOURNS®

Device Ratings (Continued)

Model	V _{rms}	V _{dc}	V _n @ 1 mA	V _c	I _c	W _{max} 10/1000 μs	P max.	I _{max} * 8/20 μs	C Typ. @ 1 kHz
	V	V	V	V	A	J	W	A	pF
SV 275 K 5	275	350	430	680	5	20	0.1	600	90
SV 275 K 7	275	350	430	680	10	44	0.25	1750	220
SV 275 K 10	275	350	430	680	25	97	0.4	3500	350
SV 275 K 14	275	350	430	680	50	187	0.6	8000	550
SV 275 K 20	275	350	430	680	100	380	1	12000	1030
SV 275 K 23	275	350	430	680	100	481	1	15000	1800
SV 300 K 7	300	385	470	700	10	46	0.25	1750	200
SV 300 K 10	300	385	470	700	25	102	0.4	3500	320
SV 300 K 14	300	385	470	700	50	211	0.6	8000	510
SV 300 K 20	300	385	470	700	100	437	1	12000	940
SV 300 K 23	300	385	470	700	100	554	1	15000	1650
SV 320 K 10	320	420	510	760	25	144	0.4	3500	300
SV 320 K 14	320	420	510	760	50	230	0.6	8000	480
SV 320 K 20	320	420	510	760	100	485	1	12000	860
SV 320 K 23	320	420	510	760	100	611	1	15000	1520
SV 385 K 10	385	505	620	900	25	116	0.4	3500	270
SV 385 K 14	385	505	620	900	50	241	0.6	8000	410
SV 385 K 20	385	505	620	900	100	495	1	12000	710
SV 385 K 23	385	505	620	900	100	624	1	15000	1250
SV 420 K 10	420	560	680	980	25	121	0.4	3500	240
SV 420 K 14	420	560	680	980	50	253	0.6	8000	380
SV 420 K 20	420	560	680	980	100	523	1	12000	680
SV 420 K 23	420	560	680	980	100	670	1	15000	1200
SV 460 K 10	460	615	750	1080	25	132	0.4	3500	230
SV 460 K 14	460	615	750	1080	50	275	0.6	8000	350
SV 460 K 20	460	615	750	1080	100	572	1	12000	620
SV 460 K 23	460	615	750	1080	100	728	1	15000	1080
SV 510 K 10	510	670	820	1200	25	144	0.4	3500	210
SV 510 K 14	510	670	820	1200	50	284	0.6	8000	330
SV 510 K 20	510	670	820	1200	100	598	1	12000	570
SV 510 K 23	510	670	820	1200	100	750	1	15000	1000
SV 550 K 10	550	745	910	1350	25	168	0.4	3500	200
SV 550 K 14	550	745	910	1350	50	330	0.6	8000	310
SV 550 K 20	550	745	910	1350	100	644	1	12000	510
SV 550 K 23	550	745	910	1350	100	815	1	15000	900

Model SVxxxK 20 with I_{max} = 1 x 15 kA @ 8/20 μs available upon request.

Model SVxxxK 23 with I_{max} = 1 x 20 kA @ 8/20 μs available upon request.

Specifications are subject to change without notice.

Users should verify actual device performance in their specific applications.

The products described herein and this document are subject to specific legal disclaimers as set forth on the last page of this document, and at www.bourns.com/docs/legal/disclaimer.pdf.

SV Series – Special Medium Voltage Varistors

BOURNS®

Product Dimensions

Model	Dimension					
	D (Max.)	t (Max.)	R	d	h (Max.)	a
SV 60 K 5	$\frac{7}{(.276)}$	$\frac{2.5}{(.098)}$	$\frac{5}{(.197)}$	$\frac{0.6}{(.024)}$	$\frac{9.5}{(.374)}$	$\frac{1.1}{(.043)}$
SV 60 K 7	$\frac{9}{(.354)}$	$\frac{3.5}{(.482)}$	$\frac{5}{(.197)}$	$\frac{0.6}{(.024)}$	$\frac{11.5}{(.453)}$	$\frac{1.1}{(.043)}$
SV 60 K 10	$\frac{12}{(.472)}$	$\frac{4.1}{(.161)}$	$\frac{7.5}{(.295)}$	$\frac{0.8}{(.031)}$	$\frac{15}{(.591)}$	$\frac{1.4}{(.055)}$
SV 60 K 14	$\frac{16}{(.630)}$	$\frac{4.2}{(.165)}$	$\frac{7.5}{(.295)}$	$\frac{0.8}{(.031)}$	$\frac{19}{(.748)}$	$\frac{1.5}{(.059)}$
SV 60 K 20	$\frac{22.5}{(.886)}$	$\frac{4.5}{(.177)}$	$\frac{10}{(.394)}$	$\frac{0.8}{(.031)}$	$\frac{26}{(1.024)}$	$\frac{1.5}{(.059)}$
SV 75 K 5	$\frac{7}{(.276)}$	$\frac{3.6}{(.142)}$	$\frac{5}{(.197)}$	$\frac{0.6}{(.024)}$	$\frac{9.5}{(.374)}$	$\frac{1.2}{(.047)}$
SV 75 K 7	$\frac{9}{(.354)}$	$\frac{3.6}{(.142)}$	$\frac{5}{(.197)}$	$\frac{0.6}{(.024)}$	$\frac{11.5}{(.453)}$	$\frac{1.2}{(.047)}$
SV 75 K 10	$\frac{12}{(.472)}$	$\frac{4.2}{(.165)}$	$\frac{7.5}{(.295)}$	$\frac{0.8}{(.031)}$	$\frac{15}{(.591)}$	$\frac{1.5}{(.059)}$
SV 75 K 14	$\frac{16}{(.630)}$	$\frac{4.2}{(.165)}$	$\frac{7.5}{(.295)}$	$\frac{0.8}{(.031)}$	$\frac{19}{(.748)}$	$\frac{1.5}{(.059)}$
SV 75 K 20	$\frac{22.5}{(.886)}$	$\frac{4.5}{(.181)}$	$\frac{10}{(.394)}$	$\frac{0.8}{(.031)}$	$\frac{26}{(1.024)}$	$\frac{1.5}{(.059)}$
SV 95 K 5	$\frac{7}{(.276)}$	$\frac{3.8}{(.150)}$	$\frac{5}{(.197)}$	$\frac{0.6}{(.024)}$	$\frac{9.5}{(.374)}$	$\frac{1.4}{(.055)}$
SV 95 K 7	$\frac{9}{(.354)}$	$\frac{3.8}{(.150)}$	$\frac{5}{(.197)}$	$\frac{0.6}{(.024)}$	$\frac{11.5}{(.453)}$	$\frac{1.4}{(.055)}$
SV 95 K 10	$\frac{12}{(.472)}$	$\frac{4.3}{(.169)}$	$\frac{7.5}{(.295)}$	$\frac{0.8}{(.031)}$	$\frac{15}{(.591)}$	$\frac{1.7}{(.067)}$
SV 95 K 14	$\frac{16}{(.630)}$	$\frac{4.3}{(.169)}$	$\frac{7.5}{(.295)}$	$\frac{0.8}{(.031)}$	$\frac{19}{(.748)}$	$\frac{1.7}{(.067)}$
SV 95 K 20	$\frac{22.5}{(.886)}$	$\frac{4.6}{(.181)}$	$\frac{10}{(.394)}$	$\frac{0.8}{(.031)}$	$\frac{26}{(1.024)}$	$\frac{1.7}{(.067)}$
SV 115 K 5	$\frac{7}{(.276)}$	$\frac{4.0}{(.157)}$	$\frac{5}{(.197)}$	$\frac{0.6}{(.024)}$	$\frac{9.5}{(.374)}$	$\frac{1.6}{(.063)}$
SV 115 K 7	$\frac{9}{(.354)}$	$\frac{4.0}{(.157)}$	$\frac{5}{(.197)}$	$\frac{0.6}{(.024)}$	$\frac{11.5}{(.453)}$	$\frac{1.6}{(.063)}$
SV 115 K 10	$\frac{12}{(.472)}$	$\frac{4.3}{(.169)}$	$\frac{7.5}{(.295)}$	$\frac{0.8}{(.031)}$	$\frac{15}{(.591)}$	$\frac{1.9}{(.075)}$
SV 115 K 14	$\frac{16}{(.630)}$	$\frac{4.4}{(.173)}$	$\frac{7.5}{(.295)}$	$\frac{0.8}{(.031)}$	$\frac{19}{(.748)}$	$\frac{1.9}{(.075)}$
SV 115 K 20	$\frac{22.5}{(.886)}$	$\frac{4.8}{(.189)}$	$\frac{10}{(.394)}$	$\frac{0.8}{(.031)}$	$\frac{26}{(1.024)}$	$\frac{1.9}{(.075)}$
SV 130 K 5	$\frac{7}{(.276)}$	$\frac{4.0}{(.157)}$	$\frac{5}{(.197)}$	$\frac{0.6}{(.024)}$	$\frac{9.5}{(.374)}$	$\frac{1.8}{(.071)}$
SV 130 K 7	$\frac{9}{(.354)}$	$\frac{4.0}{(.157)}$	$\frac{5}{(.197)}$	$\frac{0.6}{(.024)}$	$\frac{11.5}{(.453)}$	$\frac{1.8}{(.071)}$
SV 130 K 10	$\frac{12}{(.472)}$	$\frac{4.5}{(.177)}$	$\frac{7.5}{(.295)}$	$\frac{0.8}{(.031)}$	$\frac{15}{(.591)}$	$\frac{2.0}{(.079)}$
SV 130 K 14	$\frac{16}{(.630)}$	$\frac{4.6}{(.181)}$	$\frac{7.5}{(.295)}$	$\frac{0.8}{(.031)}$	$\frac{19}{(.748)}$	$\frac{2.0}{(.079)}$
SV 130 K 20	$\frac{22.5}{(.886)}$	$\frac{5.0}{(.197)}$	$\frac{10}{(.394)}$	$\frac{1}{(.039)}$	$\frac{26}{(1.024)}$	$\frac{2.2}{(.087)}$
SV 130 K 23	$\frac{25}{(.984)}$	$\frac{5.0}{(.197)}$	$\frac{10}{(.394)}$	$\frac{1}{(.039)}$	$\frac{27}{(1.063)}$	$\frac{2.2}{(.087)}$
SV 140 K 5	$\frac{7}{(.276)}$	$\frac{4.1}{(.161)}$	$\frac{5}{(.197)}$	$\frac{0.6}{(.024)}$	$\frac{9.5}{(.374)}$	$\frac{1.9}{(.075)}$
SV 140 K 7	$\frac{9}{(.354)}$	$\frac{4.1}{(.161)}$	$\frac{5}{(.197)}$	$\frac{0.6}{(.024)}$	$\frac{11.5}{(.453)}$	$\frac{1.9}{(.075)}$
SV 140 K 10	$\frac{12}{(.472)}$	$\frac{4.6}{(.181)}$	$\frac{7.5}{(.295)}$	$\frac{0.8}{(.031)}$	$\frac{15}{(.591)}$	$\frac{2.1}{(.083)}$
SV 140 K 14	$\frac{16}{(.630)}$	$\frac{4.7}{(.185)}$	$\frac{7.5}{(.295)}$	$\frac{0.8}{(.031)}$	$\frac{19}{(.748)}$	$\frac{2.1}{(.083)}$

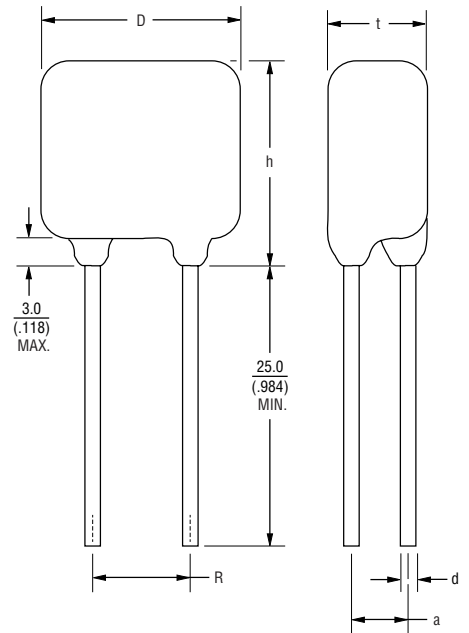

DIMENSIONS: $\frac{\text{MM}}{\text{(INCHES)}}$

Specifications are subject to change without notice.

Users should verify actual device performance in their specific applications.

The products described herein and this document are subject to specific legal disclaimers as set forth on the last page of this document, and at www.bourns.com/docs/legal/disclaimer.pdf.

SV Series – Special Medium Voltage Varistors

BOURNS®

Product Dimensions (Continued)

Model	Dimension					
	D (Max.)	t (Max.)	R	d	h (Max.)	a
SV 140 K 20	$\frac{22.5}{(.886)}$	$\frac{5.4}{(.213)}$	$\frac{10}{(.394)}$	$\frac{1}{(.039)}$	$\frac{26}{(1.024)}$	$\frac{2.3}{(.091)}$
SV 140 K 23	$\frac{25}{(.984)}$	$\frac{5.4}{(.213)}$	$\frac{10}{(.394)}$	$\frac{1}{(.039)}$	$\frac{27}{(1.063)}$	$\frac{2.3}{(.091)}$
SV 150 K 5	$\frac{7}{(.276)}$	$\frac{4.3}{(.169)}$	$\frac{5}{(.197)}$	$\frac{0.6}{(.024)}$	$\frac{9.5}{(.374)}$	$\frac{2.0}{(.079)}$
SV 150 K 7	$\frac{9}{(.354)}$	$\frac{4.3}{(.169)}$	$\frac{5}{(.197)}$	$\frac{0.6}{(.024)}$	$\frac{11.5}{(.453)}$	$\frac{2.0}{(.079)}$
SV 150 K 10	$\frac{12}{(.472)}$	$\frac{4.8}{(.189)}$	$\frac{7.5}{(.295)}$	$\frac{0.8}{(.031)}$	$\frac{15}{(.591)}$	$\frac{2.2}{(.087)}$
SV 150 K 14	$\frac{16}{(.630)}$	$\frac{4.8}{(.189)}$	$\frac{7.5}{(.295)}$	$\frac{0.8}{(.031)}$	$\frac{19}{(.748)}$	$\frac{2.2}{(.087)}$
SV 150 K 20	$\frac{22.5}{(.886)}$	$\frac{5.6}{(.220)}$	$\frac{10}{(.394)}$	$\frac{1}{(.039)}$	$\frac{26}{(1.024)}$	$\frac{2.4}{(.094)}$
SV 150 K 23	$\frac{25}{(.984)}$	$\frac{5.6}{(.220)}$	$\frac{10}{(.394)}$	$\frac{1}{(.039)}$	$\frac{27}{(1.063)}$	$\frac{2.4}{(.094)}$
SV 175 K 5	$\frac{7}{(.276)}$	$\frac{4.8}{(.189)}$	$\frac{5}{(.197)}$	$\frac{0.6}{(.024)}$	$\frac{9.5}{(.374)}$	$\frac{2.1}{(.083)}$
SV 175 K 7	$\frac{9}{(.354)}$	$\frac{4.8}{(.189)}$	$\frac{5}{(.197)}$	$\frac{0.6}{(.024)}$	$\frac{11.5}{(.453)}$	$\frac{2.1}{(.083)}$
SV 175 K 10	$\frac{12}{(.472)}$	$\frac{5.0}{(.197)}$	$\frac{7.5}{(.295)}$	$\frac{0.8}{(.031)}$	$\frac{15}{(.591)}$	$\frac{2.3}{(.091)}$
SV 175 K 14	$\frac{16}{(.630)}$	$\frac{5.0}{(.197)}$	$\frac{7.5}{(.295)}$	$\frac{0.8}{(.031)}$	$\frac{19}{(.748)}$	$\frac{2.3}{(.091)}$
SV 175 K 20	$\frac{22.5}{(.886)}$	$\frac{5.8}{(.228)}$	$\frac{10}{(.394)}$	$\frac{1}{(.039)}$	$\frac{26}{(1.024)}$	$\frac{2.5}{(.098)}$
SV 175 K 23	$\frac{25}{(.984)}$	$\frac{5.8}{(.228)}$	$\frac{10}{(.394)}$	$\frac{1}{(.039)}$	$\frac{27}{(1.063)}$	$\frac{2.5}{(.098)}$
SV 230 K 5	$\frac{7}{(.276)}$	$\frac{4.8}{(.189)}$	$\frac{5}{(.197)}$	$\frac{0.6}{(.024)}$	$\frac{9.5}{(.374)}$	$\frac{2.6}{(.102)}$
SV 230 K 7	$\frac{9}{(.354)}$	$\frac{4.8}{(.189)}$	$\frac{5}{(.197)}$	$\frac{0.6}{(.024)}$	$\frac{11.5}{(.453)}$	$\frac{2.6}{(.102)}$
SV 230 K 10	$\frac{12}{(.472)}$	$\frac{5.4}{(.213)}$	$\frac{7.5}{(.295)}$	$\frac{0.8}{(.031)}$	$\frac{15}{(.591)}$	$\frac{2.8}{(.110)}$
SV 230 K 14	$\frac{16}{(.630)}$	$\frac{5.5}{(.217)}$	$\frac{7.5}{(.295)}$	$\frac{0.8}{(.031)}$	$\frac{19}{(.748)}$	$\frac{2.8}{(.110)}$
SV 230 K 20	$\frac{22.5}{(.886)}$	$\frac{5.9}{(.232)}$	$\frac{10}{(.394)}$	$\frac{1}{(.039)}$	$\frac{26}{(1.024)}$	$\frac{3.0}{(.118)}$
SV 230 K 23	$\frac{25}{(.984)}$	$\frac{5.9}{(.232)}$	$\frac{10}{(.394)}$	$\frac{1}{(.039)}$	$\frac{27}{(1.063)}$	$\frac{3.0}{(.118)}$
SV 250 K 5	$\frac{7}{(.276)}$	$\frac{5.0}{(.197)}$	$\frac{5}{(.197)}$	$\frac{0.6}{(.024)}$	$\frac{9.5}{(.374)}$	$\frac{2.8}{(.110)}$
SV 250 K 7	$\frac{9}{(.354)}$	$\frac{5.0}{(.197)}$	$\frac{5}{(.197)}$	$\frac{0.6}{(.024)}$	$\frac{11.5}{(.453)}$	$\frac{2.8}{(.110)}$
SV 250 K 10	$\frac{12}{(.472)}$	$\frac{5.6}{(.220)}$	$\frac{7.5}{(.295)}$	$\frac{0.8}{(.031)}$	$\frac{15}{(.591)}$	$\frac{3.0}{(.118)}$
SV 250 K 14	$\frac{16}{(.630)}$	$\frac{5.7}{(.224)}$	$\frac{7.5}{(.295)}$	$\frac{0.8}{(.031)}$	$\frac{19}{(.748)}$	$\frac{3.0}{(.118)}$
SV 250 K 20	$\frac{22.5}{(.886)}$	$\frac{6.1}{(.240)}$	$\frac{10}{(.394)}$	$\frac{1}{(.039)}$	$\frac{26}{(1.024)}$	$\frac{3.2}{(.126)}$
SV 250 K 23	$\frac{25}{(.984)}$	$\frac{6.1}{(.240)}$	$\frac{10}{(.394)}$	$\frac{1}{(.039)}$	$\frac{27}{(1.063)}$	$\frac{3.2}{(.126)}$
SV 275 K 5	$\frac{7}{(.276)}$	$\frac{5.6}{(.220)}$	$\frac{5}{(.197)}$	$\frac{0.6}{(.024)}$	$\frac{9.5}{(.374)}$	$\frac{3.0}{(.118)}$
SV 275 K 7	$\frac{9}{(.354)}$	$\frac{5.6}{(.220)}$	$\frac{5}{(.197)}$	$\frac{0.6}{(.024)}$	$\frac{11.5}{(.453)}$	$\frac{3.0}{(.118)}$
SV 275 K 10	$\frac{12}{(.472)}$	$\frac{6.0}{(.236)}$	$\frac{7.5}{(.295)}$	$\frac{0.8}{(.031)}$	$\frac{15}{(.591)}$	$\frac{3.2}{(.126)}$
SV 275 K 14	$\frac{16}{(.630)}$	$\frac{6.0}{(.236)}$	$\frac{7.5}{(.295)}$	$\frac{0.8}{(.031)}$	$\frac{19}{(.748)}$	$\frac{3.2}{(.126)}$

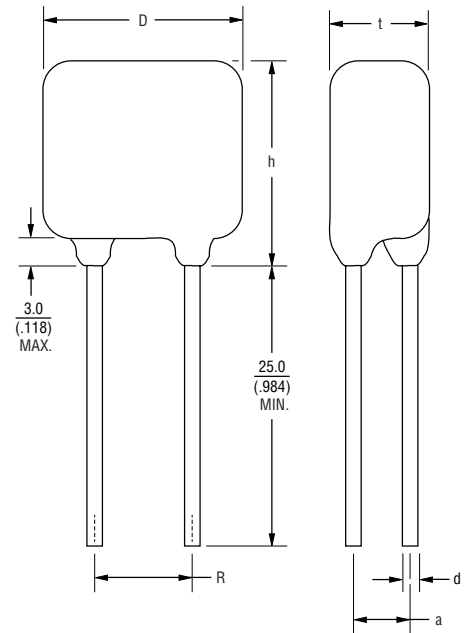

DIMENSIONS: $\frac{\text{MM}}{\text{(INCHES)}}$

Specifications are subject to change without notice.

Users should verify actual device performance in their specific applications.

The products described herein and this document are subject to specific legal disclaimers as set forth on the last page of this document, and at www.bourns.com/docs/legal/disclaimer.pdf.

SV Series – Special Medium Voltage Varistors

BOURNS®

Product Dimensions (Continued)

Model	Dimension					
	D (Max.)	t (Max.)	R	d	h (Max.)	a
SV 275 K 20	22.5 (.886)	6.3 (.248)	10 (.394)	1 (.039)	26 (1.024)	3.4 (.134)
SV 275 K 23	25 (.984)	6.3 (.248)	10 (.394)	1 (.039)	27 (1.063)	3.4 (.134)
SV 300 K 7	7 (.276)	5.8 (.228)	5 (.197)	0.6 (.024)	11.5 (.453)	3.2 (.126)
SV 300 K 10	12 (.472)	6.1 (.240)	7.5 (.295)	0.8 (.031)	15 (.591)	3.4 (.134)
SV 300 K 14	16 (.630)	6.1 (.240)	7.5 (.295)	0.8 (.031)	19 (.748)	3.4 (.134)
SV 300 K 20	22.5 (.886)	6.6 (.260)	10 (.394)	1 (.039)	27 (1.063)	3.6 (.141)
SV 300 K 23	25 (.984)	6.6 (.260)	10 (.394)	1 (.039)	29 (1.142)	3.6 (.141)
SV 320 K 10	12 (.472)	6.5 (.256)	7.5 (.295)	0.8 (.031)	15 (.591)	3.6 (.141)
SV 320 K 14	16 (.630)	6.8 (.268)	7.5 (.295)	0.8 (.031)	19 (.748)	3.6 (.141)
SV 320 K 20	22.5 (.886)	6.8 (.268)	10 (.394)	1 (.039)	27 (1.063)	3.8 (.150)
SV 320 K 23	25 (.984)	6.8 (.268)	10 (.394)	1 (.039)	29 (1.142)	3.8 (.150)
SV 385 K 10	12 (.472)	6.9 (.272)	7.5 (.295)	0.8 (.031)	15 (.591)	4.2 (.165)
SV 385 K 14	16 (.630)	6.9 (.272)	7.5 (.295)	0.8 (.031)	19 (.748)	4.2 (.165)
SV 385 K 20	22.5 (.886)	7.5 (.295)	10 (.394)	1 (.039)	27 (1.063)	4.4 (.173)
SV 385 K 23	25 (.984)	7.5 (.295)	10 (.394)	1 (.039)	29 (1.142)	4.4 (.173)
SV 420 K 10	12 (.472)	7.3 (.287)	7.5 (.295)	0.8 (.031)	15 (.591)	4.4 (.173)
SV 420 K 14	16 (.630)	7.4 (.291)	7.5 (.295)	0.8 (.031)	19 (.748)	4.4 (.173)
SV 420 K 20	22.5 (.886)	7.8 (.307)	10 (.394)	1 (.039)	27 (1.063)	4.6 (.181)
SV 420 K 23	25 (.984)	7.8 (.307)	10 (.394)	1 (.039)	29 (1.142)	4.6 (.181)
SV 460 K 10	12 (.472)	7.8 (.307)	7.5 (.295)	0.8 (.031)	15 (.591)	4.8 (.189)
SV 460 K 14	16 (.630)	7.8 (.307)	7.5 (.295)	0.8 (.031)	19 (.748)	4.8 (.189)
SV 460 K 20	22.5 (.886)	8.2 (.323)	10 (.394)	1 (.039)	27 (1.063)	5.0 (.197)
SV 460 K 23	25 (.984)	8.2 (.323)	10 (.394)	1 (.039)	29 (1.142)	5.0 (.197)
SV 510 K 10	12 (.472)	8.2 (.323)	7.5 (.295)	0.8 (.031)	15 (.591)	5.1 (.201)
SV 510 K 14	16 (.630)	8.2 (.323)	7.5 (.295)	0.8 (.031)	19 (.748)	5.1 (.201)
SV 510 K 20	22.5 (.886)	8.7 (.343)	10 (.394)	1 (.039)	27 (1.063)	5.3 (.209)
SV 510 K 23	25 (.984)	8.7 (.343)	10 (.394)	1 (.039)	29 (1.142)	5.3 (.209)
SV 550 K 10	12 (.472)	8.8 (.346)	7.5 (.295)	0.8 (.031)	15 (.591)	5.7 (.224)
SV 550 K 14	16 (.630)	8.8 (.346)	7.5 (.295)	0.8 (.031)	19 (.748)	5.7 (.224)
SV 550 K 20	22.5 (.886)	9.2 (.362)	10 (.394)	1 (.039)	27 (1.063)	5.8 (.228)
SV 550 K 23	25 (.984)	9.2 (.362)	10 (.394)	1 (.039)	29 (1.142)	5.8 (.228)

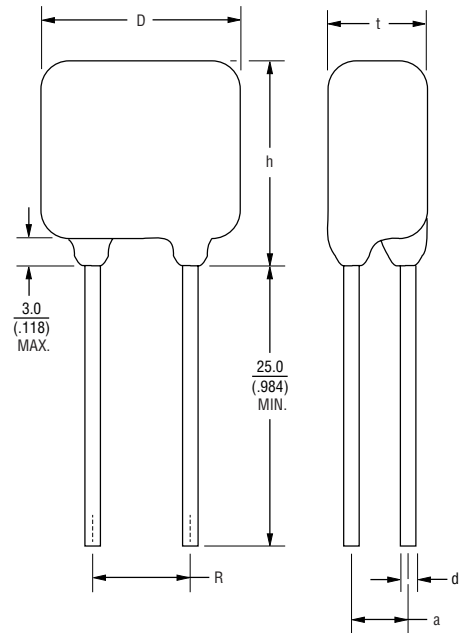

DIMENSIONS: $\frac{\text{MM}}{\text{(INCHES)}}$

Specifications are subject to change without notice.

Users should verify actual device performance in their specific applications.

The products described herein and this document are subject to specific legal disclaimers as set forth on the last page of this document, and at www.bourns.com/docs/legal/disclaimer.pdf.

SV Series – Special Medium Voltage Varistors

BOURNS®

Full Custom Parameter Designed Medium Voltage Varistors

The SV series of full custom parameter designed varistors consists of square and rectangular shaped varistors, available either as epoxy coated lead style components or as metalized pellets.

The customer can specify the varistor electrical properties and set the limits of size parameters in accordance with the General Technical Data, as provided below. The customer can also choose to have standard electrical parameters in a non-standard varistor shape and size to best fit the available housing. The customer has our full engineering support to help realize his specific protection requirement.

General Technical Data

Electrical Parameters	Value	Units
Varistor Threshold Voltage (V_n) Range at 1 mA	100 to 910	V
Continuous:		
Steady State Applied Voltage:		
DC Voltage Range (V_{dc})	85 to 745	V
AC Voltage Range (V_{rms})	60 to 550	V
Transient:		
Peak Single Pulse Surge Current, 8/20 μ s Waveform (I_{max})	> 5500	A/cm ²
Single Pulse Surge Energy, 10/1000 μ s Waveform (W_{max})	> 400	J/cm ³
Protective Level Parameters		
Clamping Voltage	< 1.9 x V_{dc}	V
Coefficient of non-linearity:		
Minimum	45	
Typical	60	
Leakage Current Level:		
@ 25 °C	0.5	μ A/cm ²
@ 85 °C	10	μ A/cm ²
Environmental Parameters		
Operating Ambient Temperature	-40 to +85	°C
Storage Temperature Range	-40 to +125	°C
Minimum Threshold Voltage		
Temperature Coefficient	-0.001	%/°C
Design Parameters		
Leaded		
Coating	Epoxy resin	
Lead Style	Straight or crimped	
Metalized Pallet	Solderable electrode finish	
Shape	Square, rectangular	
Packaging	Bulk, tape and reel	
Size Parameters		
Minimum Size	5 x 5	mm
Maximum Size	23 x 23	mm
Lead Spacing	5.0, 7.5, 10	mm
Wire Diameter	0.6, 0.8, 1.0	mm

How to Order

SV250K20BL1YY

Series Designator _____
SV = SV Series

Max. Continuous Operating Voltage (V_{rms}) _____

V_n Tolerance _____
K = \pm 10 % (Standard)
J = \pm 5 % (Available on Request)

Model Size _____
5 = 5 mm 14 = 14 mm
7 = 7 mm 20 = 20 mm
10 = 10 mm 23 = 23 mm

Packaging _____
R = Reel (Standard)*
B = Bulk (Standard)
A = Ammo Pack (Available on Request)*
**Reel and Ammo Pack options not available for Model Sizes 20 and 23.*

Lead Style _____
1 = Straight Leads
5 = Crimped Leads
M = Metalized pellet
(Available upon request)

Special Parameters _____
YY = Unique two digit suffix is assigned to each customer requesting special parameters. Please contact Bourns for more information.

Instructions for Creating Orderable Part Number:

- 1) Start with base part number in characteristics table (example: **SV250K20**).
- 2) Add Packaging: Bulk (example part number becomes **SV250K20B**).
- 3) Add Lead Style: 1 (example part number becomes **SV250K20BL1**).
- 4) Part number can have no spaces or lower case letters.

Typical Part Marking

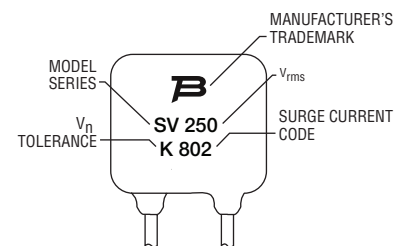

Specifications are subject to change without notice.

Users should verify actual device performance in their specific applications.

The products described herein and this document are subject to specific legal disclaimers as set forth on the last page of this document, and at www.bourns.com/docs/legal/disclaimer.pdf.

SV Series – Special Medium Voltage Varistors

BOURNS®

Pulse Rating Curves - Protection level with worst-case condition in the tolerance region

Model Size 5 - (SV60 ~ SV275)

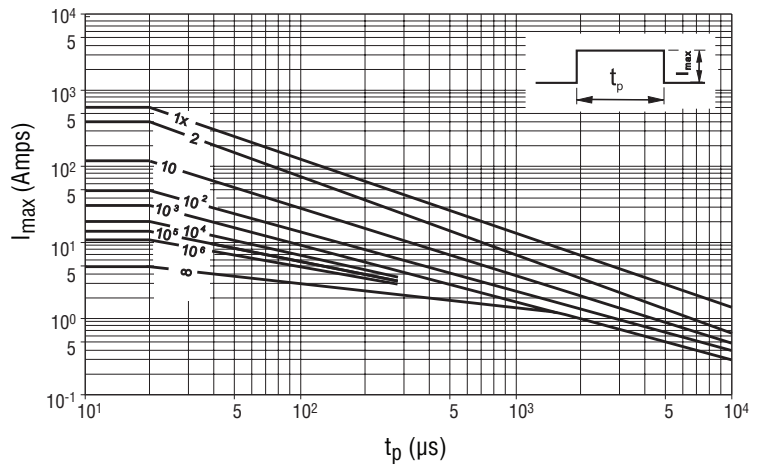
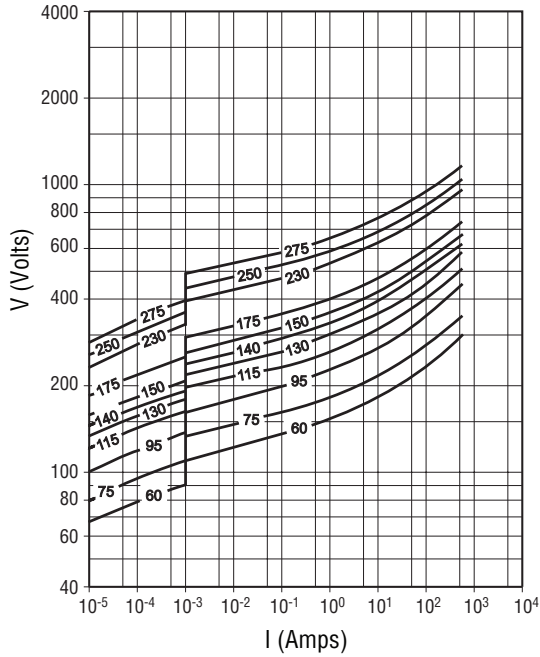

Model Size 7 - (SV60 ~ SV300)

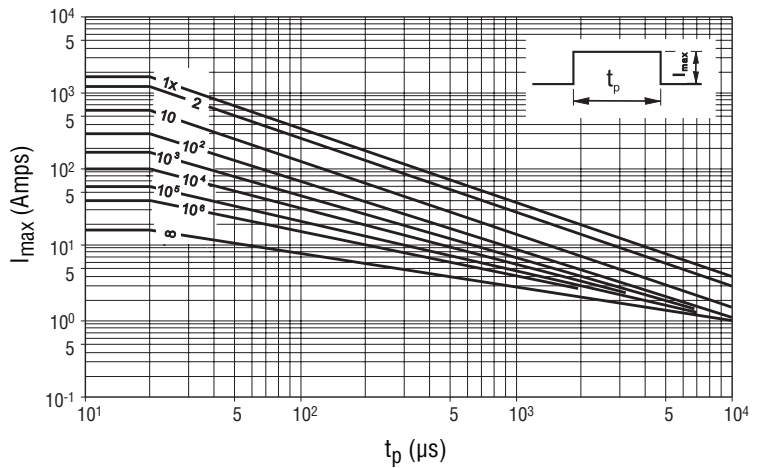
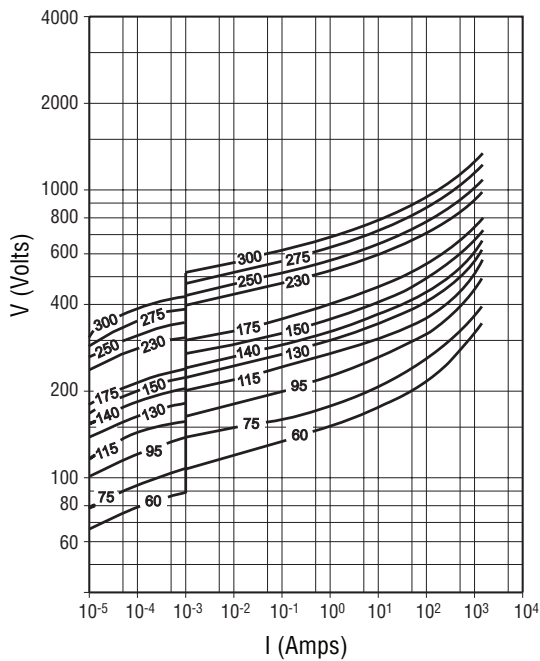

Specifications are subject to change without notice.

Users should verify actual device performance in their specific applications.

The products described herein and this document are subject to specific legal disclaimers as set forth on the last page of this document, and at www.bourns.com/docs/legal/disclaimer.pdf.

SV Series – Special Medium Voltage Varistors

BOURNS®

Pulse Rating Curves (Continued) - Protection level with worst-case condition in the tolerance region

Model Size 10 - (SV60 ~ SV550)

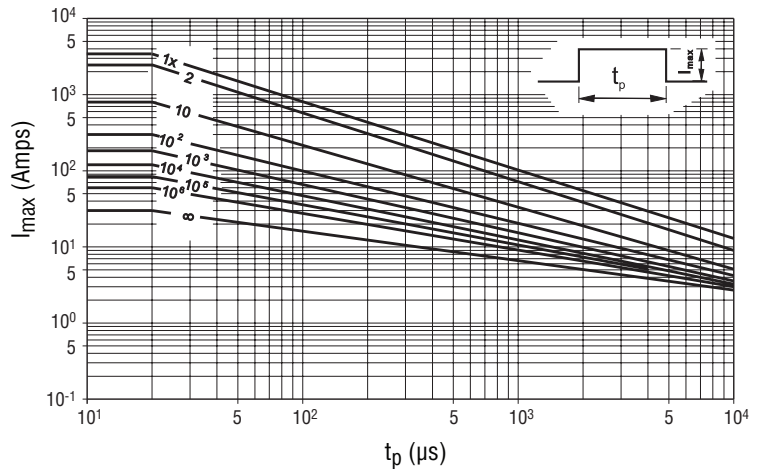
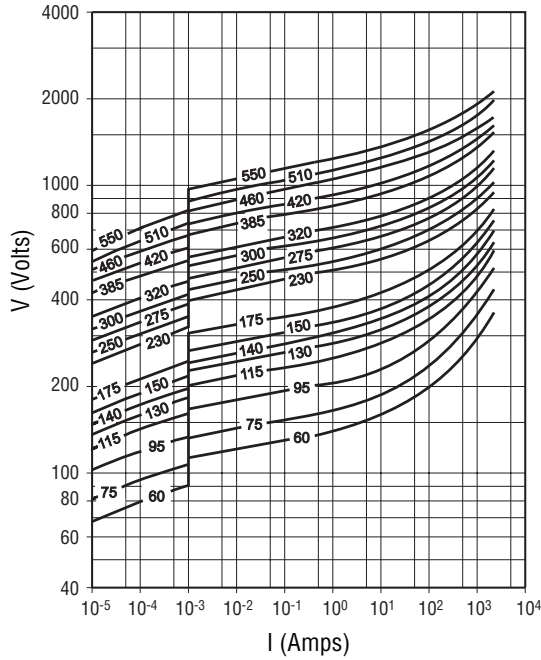

Model Size 14 - (SV60 ~ SV550)

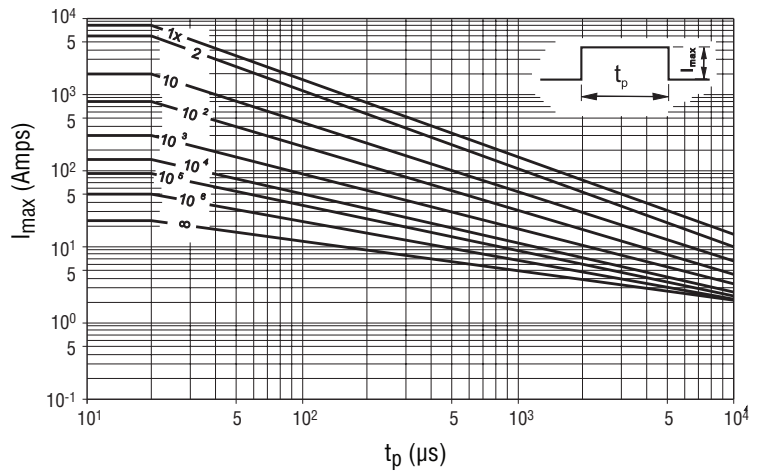
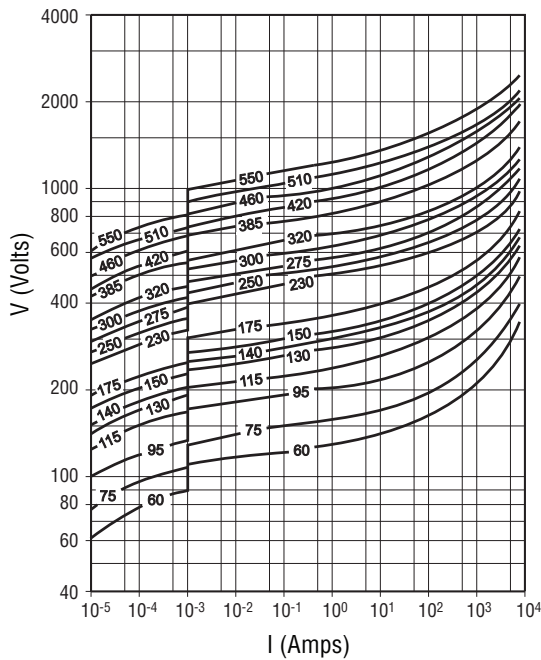

Specifications are subject to change without notice.

Users should verify actual device performance in their specific applications.

The products described herein and this document are subject to specific legal disclaimers as set forth on the last page of this document, and at www.bourns.com/docs/legal/disclaimer.pdf.

SV Series – Special Medium Voltage Varistors



Pulse Rating Curves (Continued) - Protection level with worst-case condition in the tolerance region

Model Size 20 - (SV60 ~ SV550)

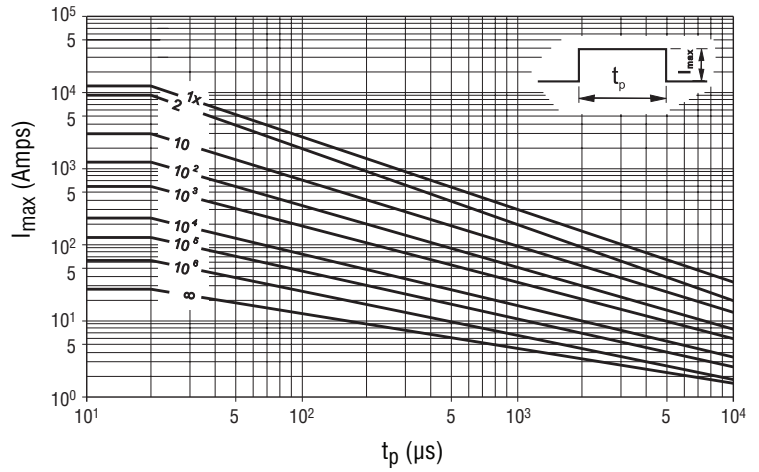
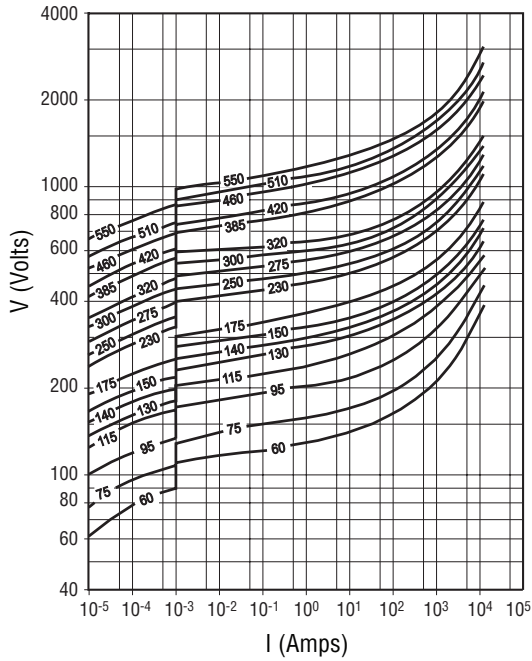

Model Size 23 - (SV130 ~ SV550)

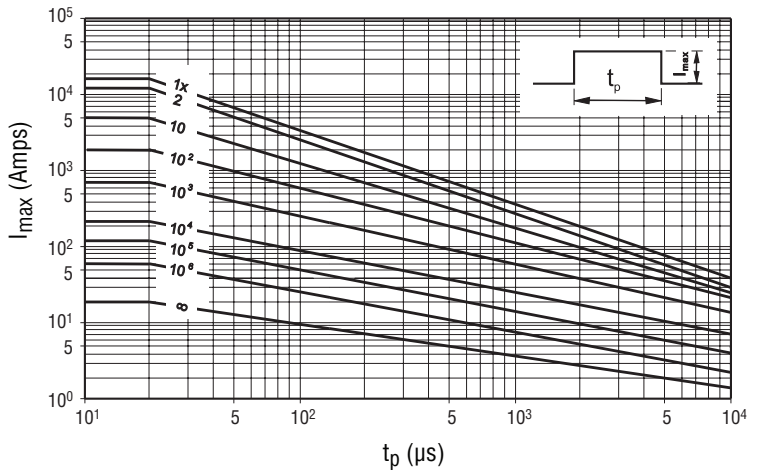
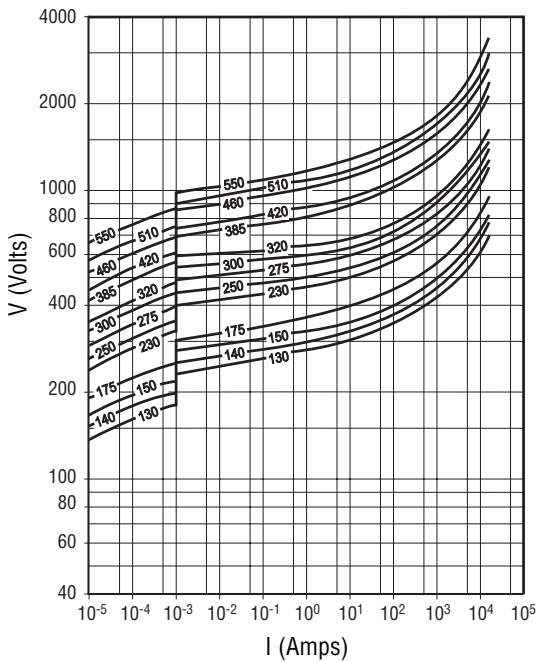

Specifications are subject to change without notice.

Users should verify actual device performance in their specific applications.

The products described herein and this document are subject to specific legal disclaimers as set forth on the last page of this document, and at www.bourns.com/docs/legal/disclaimer.pdf.

SV Series – Special Medium Voltage Varistors

BOURNS®

Packaging Specifications - Tape

Conforms to IES Publication 286-2 Ed. 3: 2008-03

Dimension R = 5 mm

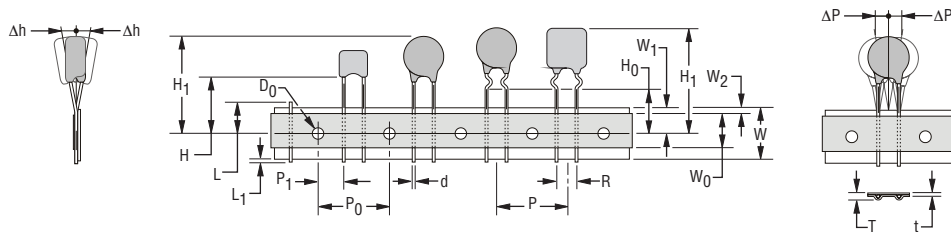

Dimensions on Next Page

Dimension R = 7.5 mm & 10 mm

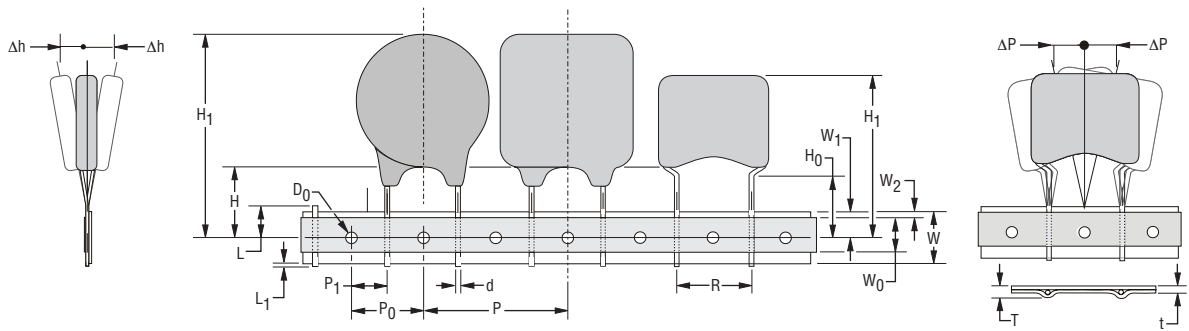

Dimensions on Next Page

Reel

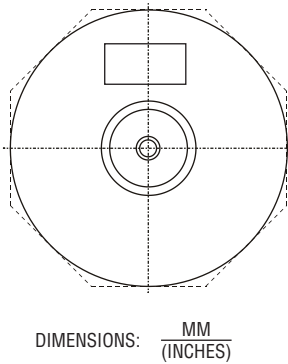
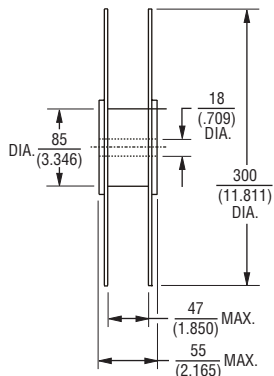

Ammo Pack (Available upon Special Request)

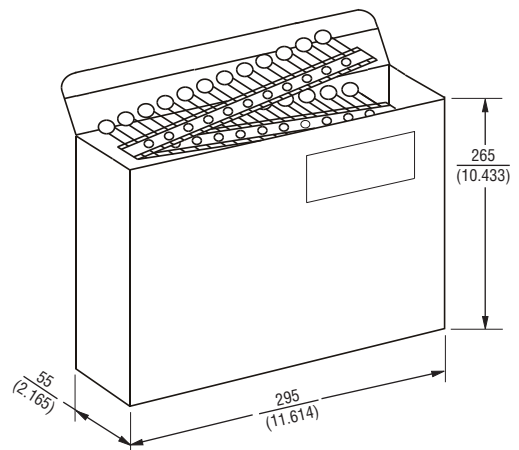

Specifications are subject to change without notice.

Users should verify actual device performance in their specific applications.

The products described herein and this document are subject to specific legal disclaimers as set forth on the last page of this document, and at www.bourns.com/docs/legal/disclaimer.pdf.

SV Series – Special Medium Voltage Varistors



Packaging Specifications - Tape (Continued)

Symbol	Parameter	Model Size				
		5	7	10	14	20
W	Carrier tape width	$\frac{18 + 1.0/-0.5}{(.709 + .039/- .020)}$				
W ₀	Hold down tape width	$\frac{5}{(.197)}$ MIN.				
W ₁	Sprocket hole position	$\frac{9 + 0.75/-0.5}{(.354 + .030/- .020)}$				
W ₂	Distance between the upper edges of the carrier tape and hold down tape	$\frac{3}{(.118)}$ MAX.				
T	Total tape thickness	$\frac{1.5}{(.059)}$ MAX.		$\frac{1.7}{(.067)}$ MAX.		$\frac{1.9}{(.075)}$ MAX.
t	Tape thickness	$\frac{0.9}{(.035)}$ MAX.				
P	Pitch of component	$\frac{12.7 \pm 1.0}{(.500 \pm .039)}$		$\frac{25.4 \pm 1.0}{(1.000 \pm .039)}$		
P ₀	Feed hole pitch	$\frac{12.7 \pm 0.3}{(.500 \pm .012)}$				
P ₁	Feed hole center to pitch	$\frac{3.85 \pm 0.7}{(.152 \pm .028)}$		$\frac{8.95 \pm 0.7}{(.352 \pm .028)}$		$\frac{7.7 \pm 0.7}{(.303 \pm .028)}$
R	Lead spacing	$\frac{5 + 0.5/-0.2}{(.197 + .020/- .008)}$		$\frac{7.5 + 0.5/-0.2}{(.295 + .020/- .008)}$		$\frac{10 + 0.5/-0.2}{(.394 + .020/- .008)}$
ΔP	Component alignment	$\frac{\pm 1.3}{(\pm .051)}$ MAX.				
Δh	Component alignment	$\frac{\pm 2}{(\pm .079)}$ MAX.				
d	Wire diameter	$\frac{0.6}{(.024)}$ MAX.		$\frac{0.8}{(.031)}$ MAX.		$\frac{1}{(.039)}$ MAX.
D ₀	Feed hold diameter	$\frac{4 \pm 0.2}{(.157 \pm .008)}$				
H	Height from tape center to component base	$\frac{18 + 2.0/-0.0}{(.709 + .079/- .000)}$				
H ₀	Seating plane height	$\frac{16 \pm 0.5}{(.630 \pm .020)}$				
H ₁	Component height	$\frac{32.2}{(1.268)}$ MAX.		$\frac{46.5}{(1.831)}$ MAX.		
L	Protrusion - cut out	$\frac{11}{(.433)}$ MAX.				
L ₁	Protrusion - cut off	$\frac{0.5}{(.020)}$ MAX.				

DIMENSIONS: $\frac{\text{MM}}{\text{(INCHES)}}$

Specifications are subject to change without notice.

Users should verify actual device performance in their specific applications.

The products described herein and this document are subject to specific legal disclaimers as set forth on the last page of this document, and at www.bourns.com/docs/legal/disclaimer.pdf.

SV Series – Special Medium Voltage Varistors

BOURNS®

Packaging Quantities - Bulk

Voltage	Model Size					
	5	7	10	14	20	23
60	1300	1000	500	400	250	
75	1300	1000	500	400	250	
95	1300	900	500	400	250	
115	1300	900	400	400	250	
130	1300	900	400	400	250	150
140	1300	900	400	400	250	150
150	1300	900	400	400	250	150
175	1300	900	400	400	250	150
230	900	900	400	250	250	150
250	900	900	400	250	250	150
275	900	900	400	250	250	150
300		900	400	250	150	100
320			400	250	150	100
385			300	250	150	100
420			300	250	150	100
460			300	250	150	100
510			300	250	150	100
550-680			300	250	150	100

Packaging Quantities - Reel

Voltage	Model Size			
	5	7	10	14
60	1500	1500	1300	600
75	1300	1300	1300	600
95	1300	1300	1200	600
115	1300	1300	1200	500
130	1300	1300	1200	500
140	1300	1300	1200	500
150	1200	1200	1000	500
175	1200	1200	1000	500
230	1000	1000	1000	500
250	1000	1000	900	400
275	1000	1000	900	400
300		900	800	400
320			800	400
385			700	300
420			700	300
460			600	300
510			600	300
550-680			600	300

Specifications are subject to change without notice.

Users should verify actual device performance in their specific applications.

The products described herein and this document are subject to specific legal disclaimers as set forth on the last page of this document, and at www.bourns.com/docs/legal/disclaimer.pdf.

Assembly Recommendations for Through-Hole Components

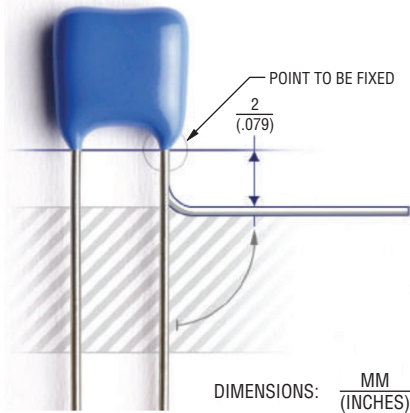

Very often before soldering through-hole components, their leads get bent. It is important not to damage the components during lead bending. Damage most commonly incurred during bending is cracks in epoxy parts, which can lead to increased humidity sensitivity of a component and, consequentially, a shorter lifetime.

In order to avoid epoxy damage, it is necessary to:

- fix the most sensitive point (epoxy parts) of a component body
- bend the wire at least 2 mm below the end of epoxy parts

Other potential damage to a component which can lead to component failure or a shorter lifetime is thermal shock during manual soldering with a soldering iron. This can occur when a soldering iron is placed too close to one point of the component body and it happens most often when the solder joint is too close to the varistor body.

Resistance to Soldering Heat

In the case of automatic wave soldering, it is important to provide sufficient resistance to soldering heat. In order to prevent any potential problems, internal standards were introduced for testing the resistance to soldering heat of through-hole components: 300 °C, 10 seconds.

Pb-free Wave Soldering Profile Recommendations

Recommended soldering profiles for all above components are in accordance with JEDEC standard curves (J-STD-020D) and are, therefore, compatible with the Pb-free process.

Lead-free Wave Soldering Profile - Pb-free wave profile requirements for soldering heat resistance of components

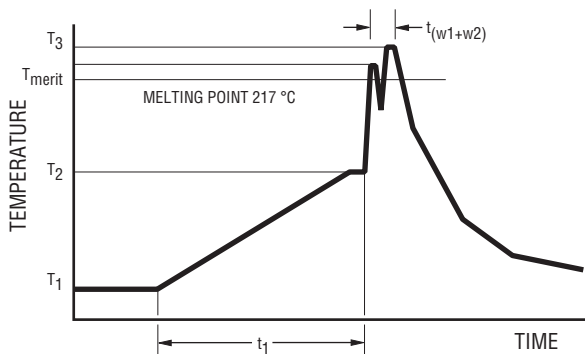

Parameter	Symbol	Specification
Preheating temperature gradient		4 °C/sec. max.
Preheating time	t_1	2 to 5 min.
Min. preheating temperature	T_1	130 °C
Max. preheating temperature	T_2	180 °C
Melting temperature/point	T_{meltv}	217 °C
Time in wave soldering phase (w_1+w_2)	t_{w1+w2}	10 sec.
Max. wave temperature (w_1+w_2)	T_s	265 °C +0/-5 °C
Cooling temperature gradient		6° C/sec. max.
Temperature jump from T_2 to T_3 (w_1)	$T_{3(w1)} - T_2$	120 °C max
Time from 25 °C to T_3 (wave temperature)		8 min. max.

Specifications are subject to change without notice.

Users should verify actual device performance in their specific applications.

The products described herein and this document are subject to specific legal disclaimers as set forth on the last page of this document, and at www.bourns.com/docs/legal/disclaimer.pdf.

SV Series – Special Medium Voltage Varistors



Reliability Testing Procedures

Varistor test procedures comply with CECC 42200, IEC 1051-1/2 (and AEC-Q200, if applicable for automotive grade products). Test results are available upon customer request. Special tests can be performed upon customer request.

Reliability Parameter	Test	Tested According to	Condition to be Satisfied after Testing
AC/DC Bias Reliability	AC/DC Life Test	CECC 42200, Test 4.20 or IEC 1051-1, Test 4.20, AEC-Q200 Test 8 - 1000 h at UCT	$ \delta V_N (1 \text{ mA}) < 10 \%$
Pulse Current Capability	$I_{\text{max}} 8/20 \mu\text{s}$	CECC 42200, Test C 2.1 or IEC 1051-1, Test 4.5 10 pulses in the same direction at 2 pulses per minute at maximum peak current for 10 pulses	$ \delta V_N (1 \text{ mA}) < 10 \%$ no visible damage
Pulse Energy Capability	$W_{\text{max}} 10/1000 \mu\text{s}$	CECC 42200, Test C 2.1 or IEC 1051-1, Test 4.5 10 pulses in the same direction at 1 pulse every 2 minutes at maximum peak current for 10 pulses	$ \delta V_N (1 \text{ mA}) < 10 \%$ no visible damage
WLD Capability	WLD x 10	ISO 7637, Test pulse 5, 10 pulses at rate of 1 per minute	$ \delta V_N (1 \text{ mA}) < 15 \%$ no visible damage
V_{jump} Capability	V _{jump} 5 min.	Increase of supply voltage to $V \geq V_{\text{jump}}$ for 1 minute	$ \delta V_N (1 \text{ mA}) < 15 \%$ no visible damage
Environmental and Storage Reliability	Climatic Sequence	CECC 42200, Test 4.16 or IEC 1051-1, Test 4.17 a) Dry heat, 16h, UCT, Test Ba, IEC 68-2-2 b) Damp heat, cyclic, the first cycle: 55 °C, 93 % RH, 24 h, Test Db 68-2-4 c) Cold, LCT, 2 h, Test Aa, IEC 68-2-1 d) Damp heat cyclic, remaining 5 cycles: 55 °C, 93 % RH, 24 h/cycle, Test Bd, IEC 68-2-30	$ \delta V_N (1 \text{ mA}) < 10 \%$
	Thermal Shock	CECC 42200, Test 4.12, Test Na, IEC 68-2-14, AEC-Q200 Test 16, 5	$ \delta V_N (1 \text{ mA}) < 10 \%$ no visible damage
	Steady State Damp Heat	CECC 42200, Test 4.17, Test Ca, IEC 68-2-3, AEC-Q200 Test 6, 56 days, 40 °C, 93 % RH, AEC-Q200 Test 7: Bias, Rh, T all at 85.	$ \delta V_N (1 \text{ mA}) < 10 \%$
	Storage Test	IEC 68-2-2, Test Ba, AEC-Q200 Test 3, 1000 h at maximum storage temperature	$ \delta V_N (1 \text{ mA}) < 5 \%$

Continued on Next Page

Specifications are subject to change without notice.

Users should verify actual device performance in their specific applications.

The products described herein and this document are subject to specific legal disclaimers as set forth on the last page of this document, and at www.bourns.com/docs/legal/disclaimer.pdf.

Reliability Testing Procedures (Continued)

Reliability Parameter	Test	Tested According to	Condition to be Satisfied after Testing
Mechanical Reliability	Solderability	CECC 42200, Test 4.10.1, Test Ta, IEC 68-2-20 solder bath and reflow method	Solderable at shipment and after 2 years of storage, criteria: >95% must be covered by solder for reflow meniscus
	Resistance to Soldering Heat	CECC 42200, Test 4.10.2, Test Tb, IEC 68-2-20 solder bath nad reflow method	$ \delta V_{11} (1 \text{ mA}) < 5 \%$
	Terminal Strength	JIS-C-6429, App. 1, 18N for 60 sec. - same for AEC-Q200 Test 22	No visual damage
	Board Flex	JIS-C-6429, App. 2, 2 mm min. AEC-Q200 test 21 - Board flex: 2 mm flex min.	$ \delta V_{11} (1 \text{ mA}) < 2 \%$ No visible damage
	Vibration	CECC 42200, Test 4.15, Test Fc, IEC 68-2-6, AEC-Q200 Test 14 Frequency range 10 to 55 Hz (AEC: 10-2000 Hz) Amplitude 0.75 m/s ² or 98 m/s ² (AEC: 5 g for 20 minutes) Total duration 6 h (3x2 h) (AEC: 12 cycles each of 3 directions) Waveshape - half sine	$ \delta V_{11} (1 \text{ mA}) < 2 \%$ No visible damage
	Mechanical Shock	CECC 42200, Test 4.14, Test Ea, IEC 68-2-27, AEC-Q200 Test 13. Acceleration = 490 m/s ² (AEC: MIL-STD-202-Method 213), Pulse duration = 11 ms, Waveshape - half sine; Number of shocks = 3x6	$ \delta V_{11} (1 \text{ mA}) < 10 \%$ No visible damage
Electrical Transient Conduction	ISO-7637-1 Pulses	AEC-Q200 Test 30: Test pulses 1 to 3. Also other pulses - freestyle.	$ \delta V_{11} (1 \text{ mA}) < 10 \%$ No visible damage

Specifications are subject to change without notice.

Users should verify actual device performance in their specific applications.

The products described herein and this document are subject to specific legal disclaimers as set forth on the last page of this document, and at www.bourns.com/docs/legal/disclaimer.pdf.

Terminology

Term	Symbol	Definition
Rated AC Voltage	V_{rms}	Maximum continuous sinusoidal AC voltage (<5 % total harmonic distortion) which may be applied to the component under continuous operation conditions at +25 °C
Rated DC Voltage.....	V_{dc}	Maximum continuous DC voltage (<5 % ripple) which may be applied to the component under continuous operating conditions at +25 °C
Supply Voltage.....	V	The voltage by which the system is designated and to which certain operating characteristics of the system are referred; $V_{rms} = 1.1 \times V$
Leakage Current.....	I_{dc}	The current passing through the varistor at V_{dc} and at +25 °C or at any other specified temperature
Varistor Voltage	V_n	Voltage across the varistor measured at a given reference current (I_n)
Reference Current.....	I_n	Reference current = 1 mA DC
Clamping Voltage	V_c	The peak voltage developed across the varistor under standard atmospheric conditions, when passing an 8/20 μs class current pulse
Protection Level		
Class Current.....	I_c	A peak value of current which is 1/10 of the maximum peak current for 100 pulses at two per minute for the 8/20 μs pulse
Voltage Clamping Ratio.....	V_c/V_{app}	A figure of merit measure of the varistor clamping effectiveness as defined by the symbols V_c/V_{app} , where ($V_{app} = V_{rms}$ or V_{dc})
Jump Start Transient	V_{jump}	The jump start transient results from the temporary application of an overvoltage in excess of the rated battery voltage. The circuit power supply may be subjected to a temporary overvoltage condition due to the voltage regulation failing or it may be deliberately generated when it becomes necessary to boost start the car.
Rated Single Pulse	W_{max}	Energy which may be dissipated for a single 10/1000 μs pulse of a maximum rated current, with rated AC voltage or rated DC voltage also applied, without causing device failure
Transient Energy		
Load Dump Transient	WLD	Load Dump is a transient which occurs in automotive environments. It is an exponentially decaying positive voltage which occurs in the event of a battery disconnect while the alternator is still generating charging current with other loads remaining on the alternator circuit at the time of battery disconnect.
Rated Peak Single Pulse.....	I_{max}	Maximum peak current which may be applied for a single 8/20 μs pulse, with rated line voltage also applied, without causing device failure
Transient Current		
Rated Transient Average	P	Maximum average power which may be dissipated due to a group of pulses occurring within a specified isolated time period, without causing device failure at 25 °C
Power Dissipation		
Capacitance.....	C	Capacitance between two terminals of the varistor measured @ 1 kHz
Non-linearity Exponent	α	A measure of varistor nonlinearity between two given operating currents, I_n and I_1 as described by $I = k V \exp(a)$, where: - k is a device constant, - $I_1 < I < I_n$ and - $a \log(I_1/I_n)/\log(V_1/V_n) = 1/\log(V_1/V_n)$, where: - I_r is reference current (1 mA) and V_n is varistor voltage - $I_1 = 10 I_n$, V_1 is the voltage measured at I_1
Response Time.....	t_r	The time lag between application of a surge and varistor's "turn-on" conduction action
Varistor Voltage Temperature	TC	$(V_n @ 85 \text{ °C} - V_n @ 25 \text{ °C}) / (V_n @ 25 \text{ °C}) \times 60 \text{ °C} \times 100$
Coefficient		
Insulation Resistance	IR.....	Minimum resistance between shorted terminals and varistor surface
Isolation Voltage		The maximum peak voltage which may be applied under continuous operating conditions between the varistor terminations and any conducting mounting surface
Operating Temperature		The range of ambient temperature for which the varistor is designed to operate continuously as defined by the temperature limits of its climatic category
Climatic Category	LCT/UCT/DHD	LCT & UCT = Lower and Upper Category Temperature - the minimum and maximum ambient temperatures for which a varistor has been designed to operate continuously. DHD = Dump Heat Test Duration
Storage Temperature.....		Storage temperature range without voltage applied
Current/Energy Derating.....		Derating of maximum values when operated above UCT

REV. G 04/25

Specifications are subject to change without notice.

Users should verify actual device performance in their specific applications.

The products described herein and this document are subject to specific legal disclaimers as set forth on the last page of this document, and at www.bourns.com/docs/legal/disclaimer.pdf.

This legal disclaimer applies to purchasers and users of Bourns® products manufactured by or on behalf of Bourns, Inc. and its affiliates (collectively, "Bourns").

Unless otherwise expressly indicated in writing, Bourns® products and data sheets relating thereto are subject to change without notice. Users should check for and obtain the latest relevant information and verify that such information is current and complete before placing orders for Bourns® products.

The characteristics and parameters of a Bourns® product set forth in its data sheet are based on laboratory conditions, and statements regarding the suitability of products for certain "typical" applications are based on Bourns' knowledge of typical requirements in generic applications. Bourns assumes that "typical" applications include failsafe/backup features to address critical risks to users and are designed to allow rework of Bourns® product to avoid scrap of a device solely due to malfunctioning Bourns® product. The characteristics and parameters of a Bourns® product in a user application may vary from the data sheet characteristics and parameters due to (i) the combination of the Bourns® product with other components in the user's application, or (ii) the environment of the user application itself. The characteristics and parameters of a Bourns® product also can and do vary in different applications and actual performance may vary over time. Thus, users should always verify the actual performance of the Bourns® product in their specific devices and applications and make their own independent judgments regarding the suitability of Bourns® product and the amount of additional test margin to design into their device or application to compensate for differences between laboratory and real-world conditions.

Unless Bourns has explicitly designated an individual Bourns® product as meeting the requirements of a particular industry standard (e.g., IATF 16949) or a particular qualification (e.g., UL listed or recognized), Bourns is not responsible for any failure of an individual Bourns® product to meet the requirements of such industry standard or particular qualification even if such industry standard or qualification is a "state of art". Users of Bourns® products are responsible for ensuring compliance with safety-related requirements and standards applicable to their devices or applications.

Bourns® products are not recommended, authorized or intended for use in applications where failure or malfunction may result in personal injury, death, or severe property or environmental damage, such as without limitation nuclear, life-critical medical and certain automotive and aviation applications. Except as set forth in the bullet points below or unless expressly and specifically approved in writing on a case-by-case basis by an authorized Bourns' representative, use of any Bourns® products in such unauthorized high-risk applications is at the user's sole risk.

- Bourns considers implantable/invasive devices and devices/procedures designed as life-supporting or life-sustaining by the U.S. Food and Drug Administration or equivalent organizations outside of the United States as "life-critical" medical applications. Bourns expressly identifies those Bourns® standard products that are suitable for use in typical medical applications that are not life-critical in its publication entitled "Bourns Medical Grade Component Guide."
- Bourns expressly identifies those Bourns® standard products that are suitable for use in typical automotive applications associated with any Automate Safety Integrity Level (ASIL) in its publication entitled "Bourns Automotive Grade Component Guide." Bourns' designation of Bourns® product as compliant with the AEC-Q standard does not by itself mean that Bourns has approved such product for use in an automotive application.
- Bourns expressly identifies Bourns® standard products that are suitable for use in the typical aviation applications/systems requiring System Design Assurance Level (RTCA DO-254 DAL) of C, D or E in its publication entitled "Bourns Civilian Aerospace/Aviation Grade Component Guide." Bourns does not test its products for compliance with United States Federal Aviation Administration standards or any other generally equivalent governmental organization standard applicable to products designed or manufactured for use in aviation applications. Use of Bourns® standard components in aviation applications associated with RTCA DO-254 DAL A or B without proper approval noted above shall be at the user's sole risk.
- Bourns will review and authorize on a case-by-case basis the use of Bourns® standard products which are at least AEC-Q compliant in space-related civil applications (rockets, satellites) with a negotiated cross-waiver and indemnity agreement.

The use and level of testing applicable to Bourns® custom products shall be negotiated on a case-by-case basis by Bourns and the user for which such Bourns® custom products are specially designed. Absent a written agreement between Bourns and the user regarding the use and level of such testing, the above provisions applicable to Bourns® standard products shall also apply to such Bourns® custom products.

Use of Bourns® products or Bourns' technology in military/defense applications must be reviewed with Bourns for compliance with applicable export control laws and embargoes. Users shall not sell, transfer, export or re-export (which includes transfers within a country) any Bourns® products or technology or technical data for use in activities which involve the design, development, production, use or stockpiling of nuclear, chemical or biological weapons or missiles, nor shall they use Bourns® products or technology or technical data in any facility which engages in activities relating to such devices. Further, Bourns® products and Bourns' technology and technical data may not under any circumstance be exported or re-exported to countries subject to international sanctions or embargoes. Bourns® products and technology may not, without prior authorization from Bourns and/or the Government of a country where such product/technology is designed and/or manufactured, be resold, transferred, or re-exported (including within the same country) to any party not eligible to receive commodities, software, and technical data originating in such country.

To the maximum extent permitted by applicable law, Bourns disclaims (i) any and all liability for special, punitive, consequential, incidental or indirect damages or lost revenues or lost profits, and (ii) any and all implied warranties (those not based on parameters specified in Bourns' data sheets and/or specifications), including implied warranties of fitness for particular purpose, non-infringement and merchantability.

For your convenience, copies of this Legal Disclaimer Notice with German, Spanish, Japanese, Traditional Chinese and Simplified Chinese bilingual versions are available at:

Web Page: <https://www.bourns.com/legal/disclaimers-terms-and-policies>

PDF: <https://www.bourns.com/docs/Legal/disclaimer.pdf>