



Features

Standard Varistor Types:

- Formerly a **KEKOVARICON** product
- Operating voltage range V_{rms} 60 V to 680 V
- Operating voltage range V_{dc} 85 V to 900 V
- 3 model sizes: 25, 32, and 40 mm
- Broad range of current and energy handling capabilities
- +85 °C continuous operating temperature
- Available either as epoxy coated varistors with rigid terminals or as metallized varistor blocks

ZOVR Series Round Shaped High Energy Varistors

General Information

The ZOVR series are round shaped high energy varistors. This series consists of three nominal model sizes - 25, 32 and 40 mm. These varistors are available as either epoxy coated varistors with rigid terminals or as metallized varistor discs. The first type is designed to provide secondary surge protection in an outdoor and service entrance environment (distribution panels), in telecommunications and also in industrial applications for motor controls and power supplies in oil-drilling, mining and transportation fields. The second type is intended for applications with special contact or installation requirements. The electrode finish of these devices is solderable and can also be used with pressure contacts for stacking applications.

Additional Information

Click these links for more information:



[PRODUCT SELECTOR](#) [TECHNICAL LIBRARY](#) [INVENTORY](#) [SAMPLES](#) [CONTACT](#)

Agency Recognition

Standard	UL 1449 4th Edition
File Number	E313168**

**Not all rated voltages and sizes are UL recognized. Check the file for details.

Varistor Symbol

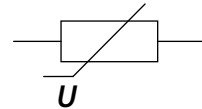

Absolute Maximum Ratings

Parameter	Standard Types	
	Value	Units
Continuous: Steady State Applied Voltage DC Voltage Range (V_{dc}) AC Voltage Range (V_{rms})	85 to 900 60 to 680	V V
Transient: Peak Single Pulse Surge Current, 8/20 μ s Waveform (I_{max}) Single Pulse Surge Energy, 10/1000 μ s Waveform (W_{max})	18000 to 40000 90 to 2590	A J
Operating Ambient Temperature	-40 to +85	°C
Storage Temperature Range	-40 to +125	°C
Minimum Threshold Voltage Temperature Coefficient	< +0.05	%/°C
Insulation Resistance ¹	> 1	G Ω
Isolation Voltage Capability ¹	> 2.5	kV
Response Time	< 25	ns
Climatic Category ¹	40 / 85 / 56	

Index

Features	1
General Information	1
Agency Recognition	1
Varistor Symbol	1
Absolute Maximum Ratings	1
Device Ratings	2-3
Product Dimensions	4
How to Order	5
Typical Part Marking	5
Protection Level/ Pulse Rating Curves	6-7
Packaging Specifications	8
Reliability Testing Procedures	9-10
Terminology	11
Legal Disclaimer	12



WARNING
Cancer and Reproductive Harm
www.P65Warnings.ca.gov

* RoHS Directive 2015/863, Mar 31, 2015 and Annex. Specifications are subject to change without notice. Users should verify actual device performance in their specific applications. The products described herein and this document are subject to specific legal disclaimers as set forth on the last page of this document, and at www.bourns.com/docs/legal/disclaimer.pdf.

ZOVR Series Round Shaped High Energy Varistors



Device Ratings

Standard High Energy Varistor Types

Model	V _{rms}	V _{dc}	V _n @ 1 mA	V _c	I _c	W _{max} 10/1000 μs	P max.	I _{max} 8/20 μs	C Typ. @ 1 kHz
	V	V	V	V	A	J	W	A	pF
ZOVR 60 K 25	60	85	100	165	150	90	1.0	18000	3850
ZOVR 60 K 32	60	85	100	165	200	250	1.2	30000	9700
ZOVR 60 K 40	60	85	100	165	300	300	1.4	40000	12000
ZOVR 75 K 25	75	100	120	200	150	100	1.0	18000	3500
ZOVR 75 K 32	75	100	120	200	200	280	1.2	30000	8900
ZOVR 75 K 40	75	100	120	200	300	340	1.4	40000	11000
ZOVR 95 K 25	95	125	150	250	150	135	1.0	18000	2950
ZOVR 95 K 32	95	125	150	250	200	380	1.2	30000	7470
ZOVR 95 K 40	95	125	150	250	300	450	1.4	40000	9200
ZOVR 130 K 25	130	170	205	340	150	180	1.0	18000	2310
ZOVR 130 K 32	130	170	205	340	200	500	1.2	30000	5780
ZOVR 130 K 40	130	170	205	340	300	600	1.4	40000	7200
ZOVR 150 K 25	150	200	240	395	150	215	1.0	18000	1990
ZOVR 150 K 32	150	200	240	395	200	600	1.2	30000	4960
ZOVR 150 K 40	150	200	240	395	300	720	1.4	40000	6100
ZOVR 230 K 25	230	300	360	595	150	320	1.0	18000	1320
ZOVR 230 K 32	230	300	360	595	200	900	1.2	30000	3300
ZOVR 230 K 40	250	300	360	595	300	1080	1.4	40000	4060
ZOVR 250 K 25	250	320	390	650	150	350	1.0	18000	1220
ZOVR 250 K 32	250	320	390	650	200	970	1.2	30000	3050
ZOVR 250 K 40	250	320	390	650	300	1160	1.4	40000	3760
ZOVR 275 K 25	275	350	430	710	150	380	1.0	18000	1100
ZOVR 275 K 32	275	350	430	710	200	1060	1.2	30000	2770
ZOVR 275 K 40	275	350	430	710	300	1280	1.4	40000	3400

Specifications are subject to change without notice.

Users should verify actual device performance in their specific applications.

The products described herein and this document are subject to specific legal disclaimers as set forth on the last page of this document, and at www.bourns.com/docs/legal/disclaimer.pdf.

ZOVR Series Round Shaped High Energy Varistors



Device Ratings (Continued)

Standard High Energy Varistor Types

Model	V _{rms}	V _{dc}	V _n @ 1 mA	V _c	I _c	W _{max} 10/1000 μs	P max.	I _{max} 8/20 μs	C Typ. @ 1 kHz
	V	V	V	V	A	J	W	A	pF
ZOVR 300 K 25	300	385	470	775	150	440	1.0	15000	1010
ZOVR 300 K 32	300	385	470	775	200	1225	1.0	30000	2540
ZOVR 300 K 40	300	385	470	775	300	1470	1.2	40000	3130
ZOVR 320 K 25	320	420	510	840	150	480	1.0	15000	990
ZOVR 320 K 32	320	420	510	840	200	1350	1.0	30000	2470
ZOVR 320 K 40	320	420	510	840	300	1620	1.2	40000	3050
ZOVR 385 K 25	385	505	620	1025	150	500	1.0	15000	810
ZOVR 385 K 32	385	505	620	1025	200	1390	1.0	30000	2040
ZOVR 385 K 40	385	505	620	1025	300	1660	1.2	40000	2500
ZOVR 420 K 25	420	560	680	1120	150	530	1.0	15000	740
ZOVR 420 K 32	420	560	680	1120	200	1480	1.0	30000	1850
ZOVR 420 K 40	420	560	680	1120	300	1780	1.2	40000	2280
ZOVR 460 K 25	460	615	750	1240	150	580	1.0	15000	670
ZOVR 460 K 32	460	615	750	1240	200	1610	1.0	30000	1680
ZOVR 460 K 40	460	615	750	1240	300	1930	1.2	40000	2060
ZOVR 510 K 25	510	670	820	1355	150	600	1.0	15000	610
ZOVR 510 K 32	510	670	820	1355	200	1680	1.0	30000	1530
ZOVR 510 K 40	510	670	820	1355	300	2010	1.2	40000	1900
ZOVR 550 K 25	550	745	910	1500	150	650	1.0	15000	550
ZOVR 550 K 32	550	745	910	1500	200	1810	1.0	30000	1380
ZOVR 550 K 40	550	745	910	1500	300	2170	1.2	40000	1700
ZOVR 680 K 25	680	895	1100	1815	150	770	1.0	15000	460
ZOVR 680 K 32	680	895	1100	1815	200	2160	1.0	30000	1150
ZOVR 680 K 40	680	895	1100	1815	300	2590	1.2	40000	1400

Specifications are subject to change without notice.

Users should verify actual device performance in their specific applications.

The products described herein and this document are subject to specific legal disclaimers as set forth on the last page of this document, and at www.bourns.com/docs/legal/disclaimer.pdf.

ZOVR Series Round Shaped High Energy Varistors



Product Dimensions

Metallized Varistor Block

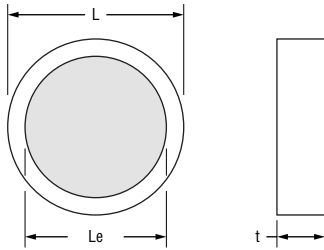

Size	Dimension	
	L (max)	Le (max)
25	$\frac{22}{(.866)}$	$\frac{18}{(.709)}$
32	$\frac{33}{(1.299)}$	$\frac{28}{(1.102)}$
40	$\frac{39}{(1.535)}$	$\frac{34}{(1.339)}$

Model	Dimension	
	t (max)	T (max)
ZOVR 60 K 25	$\frac{1.0}{(.039)}$	$\frac{7.7}{(.303)}$
ZOVR 60 K 32	$\frac{1.0}{(.039)}$	$\frac{7.7}{(.303)}$
ZOVR 60 K 40	$\frac{1.0}{(.039)}$	$\frac{7.7}{(.303)}$
ZOVR 75 K 25	$\frac{1.2}{(.047)}$	$\frac{7.9}{(.311)}$
ZOVR 75 K 32	$\frac{1.2}{(.047)}$	$\frac{7.9}{(.311)}$
ZOVR 75 K 40	$\frac{1.2}{(.047)}$	$\frac{7.9}{(.311)}$
ZOVR 95 K 25	$\frac{1.4}{(.055)}$	$\frac{8.1}{(.319)}$
ZOVR 95 K 32	$\frac{1.4}{(.055)}$	$\frac{8.1}{(.319)}$
ZOVR 95 K 40	$\frac{1.4}{(.055)}$	$\frac{8.1}{(.319)}$
ZOVR 130 K 25	$\frac{1.5}{(.059)}$	$\frac{8.1}{(.319)}$
ZOVR 130 K 32	$\frac{1.5}{(.059)}$	$\frac{8.1}{(.319)}$
ZOVR 130 K 40	$\frac{1.5}{(.059)}$	$\frac{8.1}{(.319)}$
ZOVR 150 K 25	$\frac{1.7}{(.067)}$	$\frac{8.3}{(.327)}$
ZOVR 150 K 32	$\frac{1.7}{(.067)}$	$\frac{8.3}{(.327)}$
ZOVR 150 K 40	$\frac{1.7}{(.067)}$	$\frac{8.3}{(.327)}$
ZOVR 230 K 25	$\frac{2.4}{(.094)}$	$\frac{9.0}{(.354)}$
ZOVR 230 K 32	$\frac{2.4}{(.094)}$	$\frac{9.0}{(.354)}$
ZOVR 230 K 40	$\frac{2.4}{(.094)}$	$\frac{9.0}{(.354)}$
ZOVR 250 K 25	$\frac{2.6}{(.102)}$	$\frac{9.2}{(.362)}$
ZOVR 250 K 32	$\frac{2.6}{(.102)}$	$\frac{9.2}{(.362)}$
ZOVR 250 K 40	$\frac{2.6}{(.102)}$	$\frac{9.2}{(.362)}$
ZOVR 275 K 25	$\frac{2.8}{(.110)}$	$\frac{9.4}{(.370)}$
ZOVR 275 K 32	$\frac{2.8}{(.110)}$	$\frac{9.4}{(.370)}$
ZOVR 275 K 40	$\frac{2.8}{(.110)}$	$\frac{9.4}{(.370)}$

Model	Dimension	
	t (max)	T (max)
ZOVR 300 K 25	$\frac{3.1}{(.122)}$	$\frac{9.7}{(.382)}$
ZOVR 300 K 32	$\frac{3.1}{(.122)}$	$\frac{9.7}{(.382)}$
ZOVR 300 K 40	$\frac{3.1}{(.122)}$	$\frac{9.7}{(.382)}$
ZOVR 320 K 25	$\frac{3.2}{(.126)}$	$\frac{9.9}{(.390)}$
ZOVR 320 K 32	$\frac{3.2}{(.126)}$	$\frac{9.9}{(.390)}$
ZOVR 320 K 40	$\frac{3.2}{(.126)}$	$\frac{9.9}{(.390)}$
ZOVR 385 K 25	$\frac{3.8}{(.150)}$	$\frac{10.6}{(.417)}$
ZOVR 385 K 32	$\frac{3.8}{(.150)}$	$\frac{10.6}{(.417)}$
ZOVR 385 K 40	$\frac{3.8}{(.150)}$	$\frac{10.6}{(.417)}$
ZOVR 420 K 25	$\frac{4.4}{(.173)}$	$\frac{10.9}{(.429)}$
ZOVR 420 K 32	$\frac{4.4}{(.173)}$	$\frac{10.9}{(.429)}$
ZOVR 420 K 40	$\frac{4.4}{(.173)}$	$\frac{10.9}{(.429)}$
ZOVR 460 K 25	$\frac{4.8}{(.189)}$	$\frac{11.4}{(.449)}$
ZOVR 460 K 32	$\frac{4.8}{(.189)}$	$\frac{11.4}{(.449)}$
ZOVR 460 K 40	$\frac{4.8}{(.189)}$	$\frac{11.4}{(.449)}$
ZOVR 510 K 25	$\frac{5.2}{(.205)}$	$\frac{11.8}{(.465)}$
ZOVR 510 K 32	$\frac{5.2}{(.205)}$	$\frac{11.8}{(.465)}$
ZOVR 510 K 40	$\frac{5.2}{(.205)}$	$\frac{11.8}{(.465)}$
ZOVR 550 K 25	$\frac{5.9}{(.232)}$	$\frac{12.5}{(.492)}$
ZOVR 550 K 32	$\frac{5.9}{(.232)}$	$\frac{12.5}{(.492)}$
ZOVR 550 K 40	$\frac{5.9}{(.232)}$	$\frac{12.5}{(.492)}$
ZOVR 680 K 25	$\frac{6.9}{(.272)}$	$\frac{13.5}{(.531)}$
ZOVR 680 K 32	$\frac{6.9}{(.272)}$	$\frac{13.5}{(.531)}$
ZOVR 680 K 40	$\frac{6.9}{(.272)}$	$\frac{13.5}{(.531)}$

Epoxy Coated Varistor Block

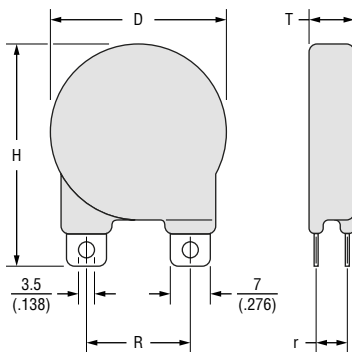

Size	Dimension		
	D (max)	R (max)	H (max)
25	$\frac{25}{(.984)}$	$\frac{19}{(.748)}$	$\frac{43}{(1.693)}$
32	$\frac{37}{(1.457)}$	$\frac{25}{(.984)}$	$\frac{55}{(2.165)}$
40	$\frac{44}{(1.732)}$	$\frac{25}{(.984)}$	$\frac{62}{(2.441)}$

DIMENSIONS: $\frac{\text{MM}}{\text{(INCHES)}}$

Note 1: Tolerance of $\pm 1 \text{ mm } (.039 \text{ in})$

Specifications are subject to change without notice.

Users should verify actual device performance in their specific applications.

The products described herein and this document are subject to specific legal disclaimers as set forth on the last page of this document, and at www.bourns.com/docs/legal/disclaimer.pdf.

ZOVR Series Round Shaped High Energy Varistors



How to Order – Metallized Varistor Block

ZOVR75K32Myy

Series Designator _____
 ZOVR = ZOVR Series

Max. Continuous Operating Voltage (V_{rms}) _____

V_n Tolerance _____
 K = $\pm 10\%$

Model Size _____
 25 = 25 mm
 32 = 32 mm
 40 = 40 mm

Design _____
 M = Metallized Varistor Block
 ME = Uncoated Block w/Rigid Terminals (available upon request)
 MP = Metallized Varistor Block w/Passivation (available upon request)

Special Requirements _____
 yy = Unique two-digit suffix assigned to each customer requesting special parameters.
 Please contact Bourns for more information.

Instructions for Creating Orderable Part Number:

- 1) Start with base part number in characteristics table (example ZOVR75K32)
- 2) Add Design: M (example part number becomes ZOVR75K32M).
- 3) Part number can have no spaces or lower case letters.

Typical Part Marking – Metallized Varistor Block

No marking.

How to Order – Epoxy Coated Varistor Block

ZOVR300K32Eyy

Series Designator _____
 ZOVR = ZOVR Series

Max. Continuous Operating Voltage (V_{rms}) _____

V_n Tolerance _____
 K = $\pm 10\%$

Model Size _____
 25 = 25 mm
 32 = 32 mm
 40 = 40 mm

Design _____
 E = Epoxy Coated Varistor w/Rigid Terminals

Special Requirements _____
 yy = Unique two-digit suffix assigned to each customer requesting special parameters.
 Please contact Bourns for more information.

Instructions for Creating Orderable Part Number:

- 1) Start with base part number in characteristics table (example ZOVR300K32)
- 2) Add Design: E (example part number becomes ZOVR300K32E).
- 3) Part number can have no spaces or lower case letters.

Typical Part Marking – Epoxy Coated Varistor Block

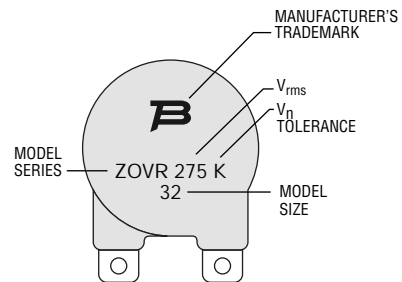

Specifications are subject to change without notice.

Users should verify actual device performance in their specific applications.

The products described herein and this document are subject to specific legal disclaimers as set forth on the last page of this document, and at www.bourns.com/docs/legal/disclaimer.pdf.

ZOVR Series Round Shaped High Energy Varistors



Device Ratings – Full Custom Parameter Designed High Energy Varistors

The ZOVR series of full custom parameter designed varistors consists of round shaped varistors, available as epoxy coated or as metallized varistor blocks. Other versions such as metallized blocks with rigid terminals, etc., or other coatings are also available.

The customer can specify the varistor electrical properties and set the limits of size parameters in accordance with the general technical data, as provided below. The customer can also choose to have standard electrical parameters in a non-standard varistor shape and size to best suit the available housing. The customer has our full engineering support in realizing his specific protection requirement.

If the model ZOVR varistor is used as a metallized block without leads and coating, device ratings and characteristics are only valid for professionally soldered and coated components. Improper soldering and further manufacturing steps can lead to a change of characteristics such as reduced long term stability, a reduced surge current and energy absorption capability, reduced adhesive strength of electrodes and low climatic strength. If a dipping soldering method is chosen, Bourns can help minimize this problem by the passivation of varistor block edges.

Protection Level

Model Size 25 - (ZOVR 60 K 25 ~ ZOVR 680 K 25)

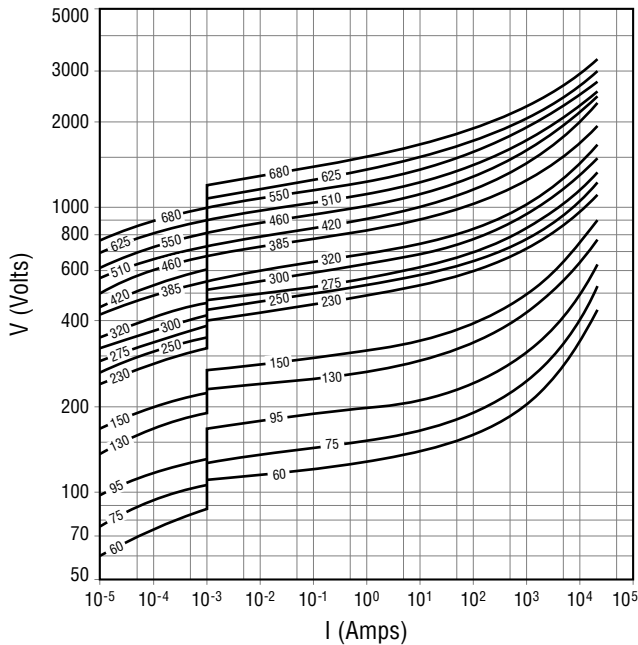

Pulse Rating Curves

Model Size 25 - (ZOVR 60 K 25 ~ ZOVR 680 K 25)

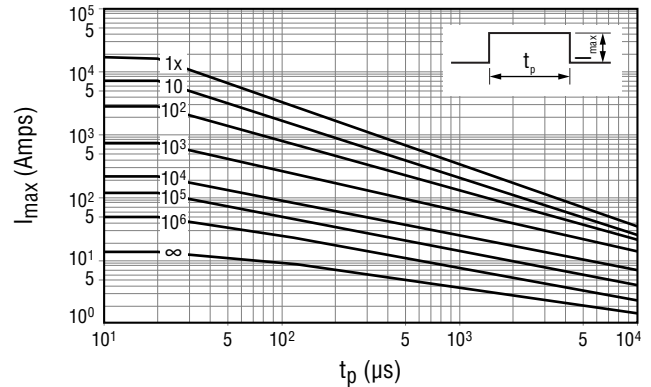

Specifications are subject to change without notice.

Users should verify actual device performance in their specific applications.

The products described herein and this document are subject to specific legal disclaimers as set forth on the last page of this document, and at www.bourns.com/docs/legal/disclaimer.pdf.

ZOVR Series Round Shaped High Energy Varistors



Protection Level

Model Size 32 - (ZOVR 60 K 32 ~ ZOVR 680 K 32)

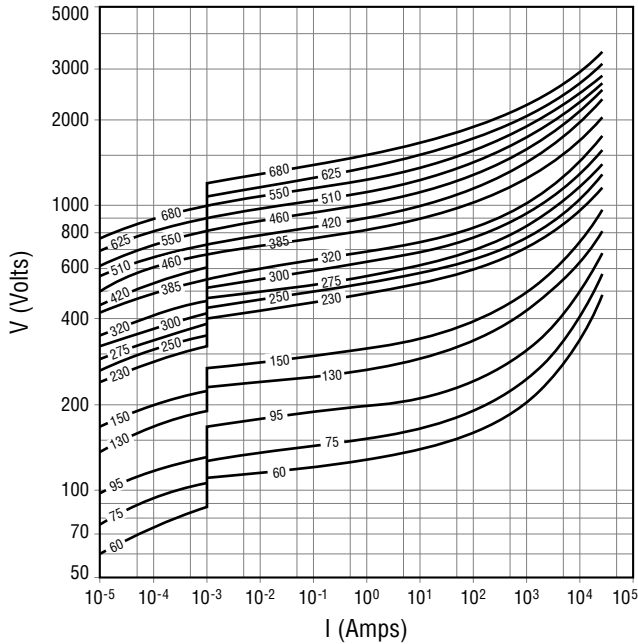

Model Size 40 - (ZOVR 60 K 40 ~ ZOVR 680 K 40)

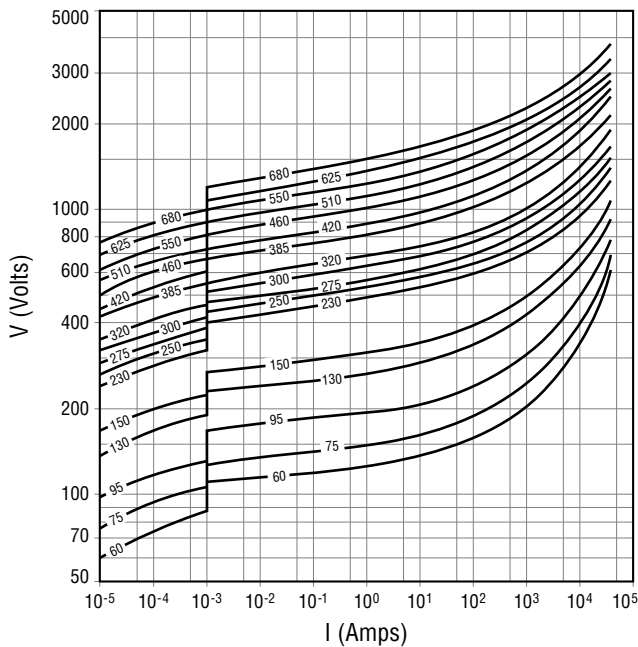

Pulse Rating Curves

Model Size 32 - (ZOVR 60 K 32 ~ ZOVR 680 K 32)

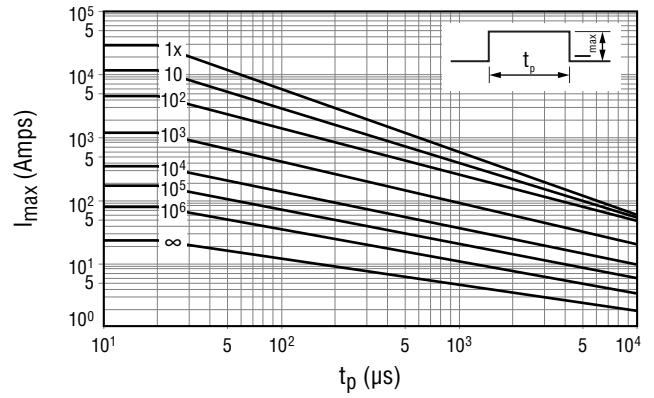

Model Size 40 - (ZOVR 60 K 40 ~ ZOVR 680 K 40)

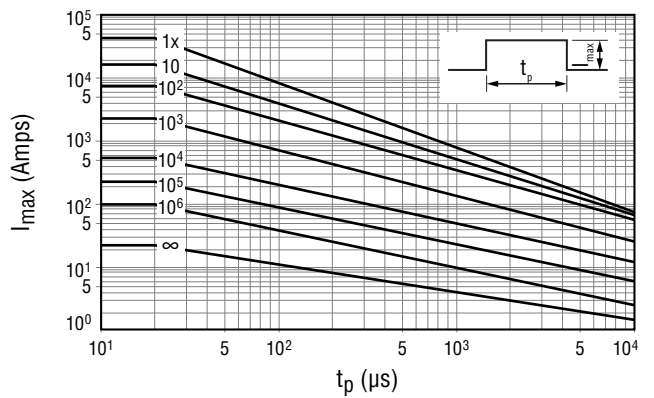

Specifications are subject to change without notice.

Users should verify actual device performance in their specific applications.

The products described herein and this document are subject to specific legal disclaimers as set forth on the last page of this document, and at www.bourns.com/docs/legal/disclaimer.pdf.

ZOVR Series Round Shaped High Energy Varistors



Packaging Quantities – Bulk

Voltage	Model Size		
	25	32	40
60	64	64	64
75	64	64	64
95	64	64	64
130	64	64	64
150	64	64	64
230	64	64	64
250	64	64	64
275	64	64	64
300	64	64	64
320	64	64	64
385	64	64	64
420	64	64	64
460	64	64	64
510	64	64	64
550	64	64	64
680	64	64	64

Specifications are subject to change without notice.

Users should verify actual device performance in their specific applications.

The products described herein and this document are subject to specific legal disclaimers as set forth on the last page of this document, and at www.bourns.com/docs/legal/disclaimer.pdf.

ZOVR Series Round Shaped High Energy Varistors



Reliability Testing Procedures (Where Applicable)

Varistor test procedures comply with CECC 42200 and IEC 1051-1/2. Test results are available upon customer request. Special tests can be performed upon customer request.

Reliability Parameter	Test	Tested According to	Condition to be Satisfied after Testing
AC/DC Bias Reliability	AC/DC Life Test	CECC 42200, Test 4.20 or IEC 1051-1, Test 4.20	$ \delta V_N (1 \text{ mA}) < 10 \%$
Pulse Current Capability	$I_{\text{max}} 8/20 \mu\text{s}$	CECC 42200, Test C 2.1 or IEC 1051-1, Test 4.5 10 pulses in the same direction at 2 pulses per minute at maximum peak current for 10 pulses	$ \delta V_N (1 \text{ mA}) < 10 \%$ no visible damage
Pulse Energy Capability	$W_{\text{max}} 10/1000 \mu\text{s}$	CECC 42200, Test C 2.1 or IEC 1051-1, Test 4.5 10 pulses in the same direction at 1 pulse every 2 minutes at maximum peak current for 10 pulses	$ \delta V_N (1 \text{ mA}) < 10 \%$ no visible damage
Environmental and Storage Reliability	Climatic Sequence	CECC 42200, Test 4.16 or IEC 1051-1, Test 4.17 a) Dry heat, 16h, UCT, Test Ba, IEC 68-2-2 b) Damp heat, cyclic, the first cycle: 55 °C, 93 % RH, 24 h, Test Db 68-2-4 c) Cold, LCT, 2 h, Test Aa, IEC 68-2-1 d) Damp heat cyclic, remaining 5 cycles: 55 °C, 93 % RH, 24 h/cycle, Test Bd, IEC 68-2-30	$ \delta V_N (1 \text{ mA}) < 10 \%$
	Thermal Shock	CECC 42200, Test 4.12, Test Na, IEC 68-2-14	$ \delta V_N (1 \text{ mA}) < 10 \%$ no visible damage
	Steady State Damp Heat	CECC 42200, Test 4.17, Test Ca, IEC 68-2-3	$ \delta V_N (1 \text{ mA}) < 10 \%$
	Storage Test	IEC 68-2-2, Test Ba, 1000 h at maximum storage temperature	$ \delta V_N (1 \text{ mA}) < 5 \%$

Continued on Next Page

Specifications are subject to change without notice.

Users should verify actual device performance in their specific applications.

The products described herein and this document are subject to specific legal disclaimers as set forth on the last page of this document, and at www.bourns.com/docs/legal/disclaimer.pdf.

ZOVR Series Round Shaped High Energy Varistors

BOURNS®

Reliability Testing Procedures (Where Applicable – Continued)

Reliability Parameter	Test	Tested According to	Condition to be Satisfied after Testing
Mechanical Reliability	Solderability	CECC 42200, Test 4.10.1, Test Ta, IEC 68-2-20 solder bath and reflow method	Solderable at shipment and after 2 years of storage, criteria: >95% must be covered by solder for reflow meniscus
	Resistance to Soldering Heat	CECC 42200, Test 4.10.2, Test Tb, IEC 68-2-20 solder bath and reflow method	$ ΔV_n (1 \text{ mA}) < 5 \%$
	Terminal Strength	JIS-C-6429, App. 1, 18 N for 60 sec.	No visual damage
	Board Flex	JIS-C-6429, App. 2, 2 mm min.	$ ΔV_n (1 \text{ mA}) < 2 \%$ No visible damage
	Vibration	CECC 42200, Test 4.15, Test Fc, IEC 68-2-6 Frequency range 10 to 55 Hz (AEC: 10-2000 Hz) Amplitude 0.75 m/s ² or 98 m/s ² (AEC: 5 g for 20 minutes) Total duration 6 h (3x2 h) (AEC: 12 cycles each of 3 directions) Waveshape - half sine	$ ΔV_n (1 \text{ mA}) < 2 \%$ No visible damage
	Mechanical Shock	CECC 42200, Test 4.14, Test Ea, IEC 68-2-27 Acceleration = 490 m/s ² (AEC: MIL-STD-202-Method 213), Pulse duration = 11 ms, Waveshape - half sine; Number of shocks = 3x6	$ ΔV_n (1 \text{ mA}) < 10 \%$ No visible damage
Electrical Transient Conduction	ISO-7637-1 Pulses	Other pulses - freestyle.	$ ΔV_n (1 \text{ mA}) < 10 \%$ No visible damage

BOURNS®

Asia-Pacific: Tel: +886-2 2562-4117 • Email: asiacus@bourns.com

EMEA: Tel: +36 88 885 877 • Email: eurocus@bourns.com

The Americas: Tel: +1-951 781-5500 • Email: americus@bourns.com

www.bourns.com

Specifications are subject to change without notice.

Users should verify actual device performance in their specific applications.

The products described herein and this document are subject to specific legal disclaimers as set forth on the last page of this document, and at www.bourns.com/docs/legal/disclaimer.pdf.

ZOVR Series Round Shaped High Energy Varistors



Terminology

Term	Symbol	Definition
Rated AC Voltage	V_{rms}	Maximum continuous sinusoidal AC voltage (<5 % total harmonic distortion) which may be applied to the component under continuous operation conditions at +25 °C
Rated DC Voltage	V_{dc}	Maximum continuous DC voltage (<5 % ripple) which may be applied to the component under continuous operating conditions at +25 °C
Supply Voltage	V	The voltage by which the system is designated and to which certain operating characteristics of the system are referred; $V_{rms} = 1.1 \times V$
Leakage Current	I_{dc}	The current passing through the varistor at V_{dc} and at +25 °C or at any other specified temperature
Varistor Voltage	V_n	Voltage across the varistor measured at a given reference current (I_n)
Reference Current	I_n	Reference current = 1 mA DC
Clamping Voltage	V_c	The peak voltage developed across the varistor under standard atmospheric conditions, when passing an 8/20 μs class current pulse
Protection Level		
Clamping Current	I_c	A peak value of current which is used to measure the functionality of the varistor.
Voltage Clamping Ratio	V_c/V_{app}	A figure of merit measure of the varistor clamping effectiveness as defined by the symbols V_c/V_{app} , where ($V_{app} = V_{rms}$ or V_{dc})
Rated Single Pulse	W_{max}	Energy which may be dissipated for a single 10/1000 μs pulse of a maximum rated current, with rated AC voltage or rated DC voltage also applied, without causing device failure
Transient Energy		
Rated Peak Single Pulse	I_{max}	Maximum peak current which may be applied for a single 8/20 μs pulse, with rated line voltage also applied, without causing device failure
Transient Current		
Rated Transient Average	P	Maximum average power which may be dissipated due to a group of pulses occurring within a specified isolated time period, without causing device failure at 25 °C
Power Dissipation		
Capacitance	C	Capacitance between two terminals of the varistor measured @ 1 kHz
Non-linearity Exponent	α	A measure of varistor nonlinearity between two given operating currents, I_n and I_1 as described by $I = k V \exp(a)$, where: <ul style="list-style-type: none"> - k is a device constant, - $I_1 < I < I_n$ and - $a \log(I_1/I_n) / \log(V_1/V_n) = 1 / \log(V_1/V_n)$, where: <ul style="list-style-type: none"> - I_r is reference current (1 mA) and V_n is varistor voltage - $I_1 = 10 I_n$, V_1 is the voltage measured at I_1
Response Time	t_r	The time lag between application of a surge and varistor's "turn-on" conduction action
Varistor Voltage Temperature	TC	$(V_n @ 85 \text{ °C} - V_n @ 25 \text{ °C}) / (V_n @ 25 \text{ °C}) \times 60 \text{ °C} \times 100$
Coefficient		
Insulation Resistance	IR	Minimum resistance between shorted terminals and varistor surface
Isolation Voltage		The maximum peak voltage which may be applied under continuous operating conditions between the varistor terminations and any conducting mounting surface
Operating Temperature		The range of ambient temperature for which the varistor is designed to operate continuously as defined by the temperature limits of its climatic category
Climatic Category	LCT/UCT/DHD	LCT & UCT = Lower and Upper Category Temperature - the minimum and maximum ambient temperatures for which a varistor has been designed to operate continuously. DHD = Dump Heat Test Duration
Storage Temperature		Storage temperature range without voltage applied
Current/Energy Derating		Derating of maximum values when operated above UCT

REV. A 01/20

Specifications are subject to change without notice.

Users should verify actual device performance in their specific applications.

The products described herein and this document are subject to specific legal disclaimers as set forth on the last page of this document, and at www.bourns.com/docs/legal/disclaimer.pdf.

This legal disclaimer applies to purchasers and users of Bourns® products manufactured by or on behalf of Bourns, Inc. and its affiliates (collectively, “Bourns”).

Unless otherwise expressly indicated in writing, Bourns® products and data sheets relating thereto are subject to change without notice. Users should check for and obtain the latest relevant information and verify that such information is current and complete before placing orders for Bourns® products.

The characteristics and parameters of a Bourns® product set forth in its data sheet are based on laboratory conditions, and statements regarding the suitability of products for certain types of applications are based on Bourns’ knowledge of typical requirements in generic applications. The characteristics and parameters of a Bourns® product in a user application may vary from the data sheet characteristics and parameters due to (i) the combination of the Bourns® product with other components in the user’s application, or (ii) the environment of the user application itself. The characteristics and parameters of a Bourns® product also can and do vary in different applications and actual performance may vary over time. Users should always verify the actual performance of the Bourns® product in their specific devices and applications, and make their own independent judgments regarding the amount of additional test margin to design into their device or application to compensate for differences between laboratory and real world conditions.

Unless Bourns has explicitly designated an individual Bourns® product as meeting the requirements of a particular industry standard (e.g., ISO/TS 16949) or a particular qualification (e.g., UL listed or recognized), Bourns is not responsible for any failure of an individual Bourns® product to meet the requirements of such industry standard or particular qualification. Users of Bourns® products are responsible for ensuring compliance with safety-related requirements and standards applicable to their devices or applications.

Bourns® products are not recommended, authorized or intended for use in nuclear, lifesaving, life-critical or life-sustaining applications, nor in any other applications where failure or malfunction may result in personal injury, death, or severe property or environmental damage. Unless expressly and specifically approved in writing by two authorized Bourns representatives on a case-by-case basis, use of any Bourns® products in such unauthorized applications might not be safe and thus is at the user’s sole risk. Life-critical applications include devices identified by the U.S. Food and Drug Administration as Class III devices and generally equivalent classifications outside of the United States.

Bourns expressly identifies those Bourns® standard products that are suitable for use in automotive applications on such products’ data sheets in the section entitled “Applications.” Unless expressly and specifically approved in writing by two authorized Bourns representatives on a case-by-case basis, use of any other Bourns® standard products in an automotive application might not be safe and thus is not recommended, authorized or intended and is at the user’s sole risk. If Bourns expressly identifies a sub-category of automotive application in the data sheet for its standard products (such as infotainment or lighting), such identification means that Bourns has reviewed its standard product and has determined that if such Bourns® standard product is considered for potential use in automotive applications, it should only be used in such sub-category of automotive applications. Any reference to Bourns® standard product in the data sheet as compliant with the AEC-Q standard or “automotive grade” does not by itself mean that Bourns has approved such product for use in an automotive application.

Bourns® standard products are not tested to comply with United States Federal Aviation Administration standards generally or any other generally equivalent governmental organization standard applicable to products designed or manufactured for use in aircraft or space applications. Bourns expressly identifies Bourns® standard products that are suitable for use in aircraft or space applications on such products’ data sheets in the section entitled “Applications.” Unless expressly and specifically approved in writing by two authorized Bourns representatives on a case-by-case basis, use of any other Bourns® standard product in an aircraft or space application might not be safe and thus is not recommended, authorized or intended and is at the user’s sole risk.

The use and level of testing applicable to Bourns® custom products shall be negotiated on a case-by-case basis by Bourns and the user for which such Bourns® custom products are specially designed. Absent a written agreement between Bourns and the user regarding the use and level of such testing, the above provisions applicable to Bourns® standard products shall also apply to such Bourns® custom products.

Users shall not sell, transfer, export or re-export any Bourns® products or technology for use in activities which involve the design, development, production, use or stockpiling of nuclear, chemical or biological weapons or missiles, nor shall they use Bourns® products or technology in any facility which engages in activities relating to such devices. The foregoing restrictions apply to all uses and applications that violate national or international prohibitions, including embargos or international regulations. Further, Bourns® products and Bourns technology and technical data may not under any circumstance be exported or re-exported to countries subject to international sanctions or embargoes. Bourns® products may not, without prior authorization from Bourns and/or the U.S. Government, be resold, transferred, or re-exported to any party not eligible to receive U.S. commodities, software, and technical data.

To the maximum extent permitted by applicable law, Bourns disclaims (i) any and all liability for special, punitive, consequential, incidental or indirect damages or lost revenues or lost profits, and (ii) any and all implied warranties, including implied warranties of fitness for particular purpose, non-infringement and merchantability.

For your convenience, copies of this Legal Disclaimer Notice with German, Spanish, Japanese, Traditional Chinese and Simplified Chinese bilingual versions are available at:

Web Page: <http://www.bourns.com/legal/disclaimers-terms-and-policies>

PDF: <http://www.bourns.com/docs/Legal/disclaimer.pdf>