



Features

- Formerly a **KEKO**VARICON product
- Five model sizes available - 5, 7, 10, 14 and 20 mm
- Operating voltage range (V_{dc}) 3 V to 56 V
- Broad range of current and energy handling capability
- Low clamping voltage

- Available in tape and reel for automatic insertion equipment
- +125 °C maximum continuous operating temperature

ZV Series - Low Voltage Leaded Style Varistors

General Information

The ZV series of low voltage varistors is designed to protect sensitive electronic devices against high voltage and current surges in the low voltage region.

They offer excellent transient energy absorption due to improved energy volume distribution and power dissipation.

Low voltage varistors cover a wide DC operating voltage range from 3 V to 56 V.

Absolute Maximum Ratings

Parameter	Value	Units
Continuous:		
Steady State Applied Voltage		
DC Voltage Range (V_{dc})	3 to 56***	V
AC Voltage Range (V_{rms})	2 to 40***	V
Transient:		
Peak Single Pulse Surge Current, 8/20 μ s Waveform (I_{max})	100 to 2000	A
Single Pulse Surge Energy, 10/1000 μ s Waveform (W_{max})	0.1 to 37.8	J
Operating Ambient Temperature	-55 to +125	°C
Storage Temperature Range	-55 to +150	°C
Threshold Voltage Temperature Coefficient	< +0.05	%/°C
Insulation Resistance	>1	G Ω
Isolation Voltage Capability	>1.25	kV
Response Time	< 25	ns
Climatic Category	55 / 125 / 56	

*** Higher operating voltages are available upon request.
Varistors with rated voltages of 2 to 8 V_{rms} are non-standard and available only upon request.

BOURNS®

Asia-Pacific: Tel: +886-2 2562-4117 • Email: asiacus@bourns.com

EMEA: Tel: +36 88 885 877 • Email: eurocus@bourns.com

The Americas: Tel: +1-951 781-5500 • Email: americus@bourns.com

www.bourns.com

Additional Information

Click these links for more information:



[PRODUCT SELECTOR](#) [TECHNICAL LIBRARY](#) [INVENTORY](#) [SAMPLES](#) [CONTACT](#)

Agency Recognition

Standard	UL 1449
File Number	E313168**

**Not all rated voltages are UL recognized; check the file for details.

Varistor Symbol

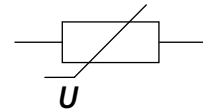

Index

Features	1
General Information	1
Agency Recognition	1
Varistor Symbol	1
Absolute Maximum Ratings	1
Applications	2
Device Ratings	2
Product Dimensions	3-4
How to Order	4
Typical Part Marking	4
Pulse Rating Curves	5-7
Packaging Drawings	8
Packaging Specifications	9-10
Assembly Recommendations for Through-Hole Components	11
Terminology	12
Legal Disclaimer	13



WARNING Cancer and Reproductive Harm - www.P65Warnings.ca.gov

*RoHS Directive 2015/863, Mar 31, 2015 and Annex.

Specifications are subject to change without notice.

Users should verify actual device performance in their specific applications.

The products described herein and this document are subject to specific legal disclaimers as set forth on the last page of this document, and at www.bourns.com/docs/legal/disclaimer.pdf.

Applications

- Suppression of inductive switching or other transient events such as surge voltage at the circuit board level
- Transient voltage protection for ICs and transistors
- Helps to achieve electromagnetic compliance of end products
- Replaces larger TVS zener diodes in many applications

ZV Series – Low Voltage Leaded Style Varistors

BOURNS®

Device Ratings

Model	V _{rms}	V _{dc}	V _n @ 1 mA	V _c	I _c	W _{max} 10/1000 μs	P max.	I _{max} 8/20 μs	C typ. @ 1 kHz
	V	V	V	V	A	J	W	A	pF
ZV 11 K 5	11	14	18	33	1	0.3	0.005	100	480
ZV 11 K 7	11	14	18	33	1	0.8	0.008	250	1400
ZV 11 K 10	11	14	18	33	2.5	1.7	0.010	500	2420
ZV 11 K 14	11	14	18	33	5	3.3	0.015	1000	5000
ZV 11 K 20	11	14	18	33	10	10.5	0.020	2000	9270
ZV 14 K 5	14	18	22	38	1	0.4	0.005	100	377
ZV 14 K 7	14	18	22	38	1	0.9	0.008	250	1050
ZV 14 K 10	14	18	22	38	2.5	2.2	0.010	500	1770
ZV 14 K 14	14	18	22	38	5	4.2	0.015	1000	3850
ZV 14 K 20	14	18	22	38	10	12	0.020	2000	7670
ZV 17 K 5	17	22	27	44	1	0.5	0.005	100	335
ZV 17 K 7	17	22	27	44	1	1.2	0.008	250	850
ZV 17 K 10	17	22	27	44	2.5	2.6	0.010	500	1370
ZV 17 K 14	17	22	27	44	5	5.2	0.015	1000	3050
ZV 17 K 20	17	22	27	44	10	14.2	0.020	2000	6600
ZV 20 K 5	20	26	33	54	1	0.6	0.005	100	325
ZV 20 K 7	20	26	33	54	1	1.4	0.008	250	790
ZV 20 K 10	20	26	33	54	2.5	3.2	0.010	500	1090
ZV 20 K 14	20	26	33	54	5	6.4	0.015	1000	2490
ZV 20 K 20	20	26	33	54	10	18.2	0.020	2000	5670
ZV 25 K 5	25	31	39	65	1	0.7	0.005	100	315
ZV 25 K 7	25	31	39	65	1	1.6	0.008	250	790
ZV 25 K 10	25	31	39	65	2.5	3.8	0.010	500	870
ZV 25 K 14	25	31	39	65	5	7.2	0.015	1000	1890
ZV 25 K 20	25	31	39	65	10	22.4	0.020	2000	4670
ZV 30 K 5	30	38	47	77	1	0.9	0.005	100	315
ZV 30 K 7	30	38	47	77	1	2.2	0.008	250	790
ZV 30 K 10	30	38	47	77	2.5	4.4	0.010	500	770
ZV 30 K 14	30	38	8	77	5	9.4	0.015	1000	1530
ZV 30 K 20	30	38	47	77	10	25.8	0.020	2000	3870
ZV 35 K 5	35	45	56	90	1	1.2	0.005	100	315
ZV 35 K 7	35	45	56	90	1	2.6	0.008	250	790
ZV 35 K 10	35	45	56	90	2.5	5.4	0.010	500	680
ZV 35 K 14	35	45	56	90	5	10.2	0.015	1000	1260
ZV 35 K 20	35	45	56	90	10	33.4	0.020	2000	3470
ZV 40 K 5	40	56	68	110	1	1.4	0.005	100	315
ZV 40 K 7	40	56	68	110	1	3.2	0.008	250	790
ZV 40 K 10	40	56	68	110	2.5	6.4	0.010	500	660
ZV 40 K 14	40	56	68	110	5	13.4	0.015	1000	1070
ZV 40 K 20	40	56	68	110	10	37.8	0.020	2000	3130

Specifications are subject to change without notice.

Users should verify actual device performance in their specific applications.

The products described herein and this document are subject to specific legal disclaimers as set forth on the last page of this document, and at www.bourns.com/docs/legal/disclaimer.pdf.

ZV Series – Low Voltage Leaded Style Varistors

BOURNS®

Product Dimensions

Model	D max.	t max.	R	d	h max.
ZV 11 K 5	$\frac{6.0}{(.236)}$	$\frac{3.5}{(.138)}$	$\frac{5.0}{(.197)}$	$\frac{0.6}{(.024)}$	$\frac{7.0}{(.276)}$
ZV 11 K 7	$\frac{7.0}{(.276)}$	$\frac{3.5}{(.138)}$	$\frac{5.0}{(.197)}$	$\frac{0.6}{(.024)}$	$\frac{8.0}{(.315)}$
ZV 11 K 10	$\frac{7.0}{(.276)}$	$\frac{3.5}{(.138)}$	$\frac{5.0}{(.197)}$	$\frac{0.6}{(.024)}$	$\frac{9.0}{(.354)}$
ZV 11 K 14	$\frac{8.0}{(.315)}$	$\frac{3.5}{(.138)}$	$\frac{5.0}{(.197)}$	$\frac{0.6}{(.024)}$	$\frac{12.0}{(.472)}$
ZV 11 K 20	$\frac{9.0}{(.354)}$	$\frac{3.5}{(.138)}$	$\frac{5.0}{(.197)}$	$\frac{0.6}{(.024)}$	$\frac{12.0}{(.472)}$
ZV 14 K 5	$\frac{6.0}{(.236)}$	$\frac{3.5}{(.138)}$	$\frac{5.0}{(.197)}$	$\frac{0.6}{(.024)}$	$\frac{7.0}{(.276)}$
ZV 14 K 7	$\frac{7.0}{(.276)}$	$\frac{3.5}{(.138)}$	$\frac{5.0}{(.197)}$	$\frac{0.6}{(.024)}$	$\frac{8.0}{(.315)}$
ZV 14 K 10	$\frac{7.0}{(.276)}$	$\frac{3.5}{(.138)}$	$\frac{5.0}{(.197)}$	$\frac{0.6}{(.024)}$	$\frac{9.0}{(.354)}$
ZV 14 K 14	$\frac{8.0}{(.315)}$	$\frac{3.5}{(.138)}$	$\frac{5.0}{(.197)}$	$\frac{0.6}{(.024)}$	$\frac{12.0}{(.472)}$
ZV 14 K 20	$\frac{9.0}{(.354)}$	$\frac{3.5}{(.138)}$	$\frac{5.0}{(.197)}$	$\frac{0.6}{(.024)}$	$\frac{12.0}{(.472)}$
ZV 17 K 5	$\frac{6.0}{(.236)}$	$\frac{3.5}{(.138)}$	$\frac{5.0}{(.197)}$	$\frac{0.6}{(.024)}$	$\frac{7.0}{(.276)}$
ZV 17 K 7	$\frac{7.0}{(.276)}$	$\frac{3.5}{(.138)}$	$\frac{5.0}{(.197)}$	$\frac{0.6}{(.024)}$	$\frac{8.0}{(.315)}$
ZV 17 K 10	$\frac{7.0}{(.276)}$	$\frac{3.5}{(.138)}$	$\frac{5.0}{(.197)}$	$\frac{0.6}{(.024)}$	$\frac{9.0}{(.354)}$
ZV 17 K 14	$\frac{8.0}{(.315)}$	$\frac{3.5}{(.138)}$	$\frac{5.0}{(.197)}$	$\frac{0.6}{(.024)}$	$\frac{12.0}{(.472)}$
ZV 17 K 20	$\frac{9.0}{(.354)}$	$\frac{3.5}{(.138)}$	$\frac{5.0}{(.197)}$	$\frac{0.6}{(.024)}$	$\frac{12.0}{(.472)}$
ZV 20 K 5	$\frac{6.0}{(.236)}$	$\frac{4.5}{(.177)}$	$\frac{5.0}{(.197)}$	$\frac{0.6}{(.024)}$	$\frac{7.0}{(.276)}$
ZV 20 K 7	$\frac{7.0}{(.276)}$	$\frac{4.5}{(.177)}$	$\frac{5.0}{(.197)}$	$\frac{0.6}{(.024)}$	$\frac{8.0}{(.315)}$
ZV 20 K 10	$\frac{7.0}{(.276)}$	$\frac{4.5}{(.177)}$	$\frac{5.0}{(.197)}$	$\frac{0.6}{(.024)}$	$\frac{9.0}{(.354)}$
ZV 20 K 14	$\frac{8.0}{(.315)}$	$\frac{4.5}{(.177)}$	$\frac{5.0}{(.197)}$	$\frac{0.6}{(.024)}$	$\frac{12.0}{(.472)}$
ZV 20 K 20	$\frac{9.0}{(.354)}$	$\frac{4.5}{(.177)}$	$\frac{5.0}{(.197)}$	$\frac{0.6}{(.024)}$	$\frac{12.0}{(.472)}$
ZV 25 K 5	$\frac{6.0}{(.236)}$	$\frac{4.5}{(.177)}$	$\frac{5.0}{(.197)}$	$\frac{0.6}{(.024)}$	$\frac{7.0}{(.276)}$
ZV 25 K 7	$\frac{7.0}{(.276)}$	$\frac{4.5}{(.177)}$	$\frac{5.0}{(.197)}$	$\frac{0.6}{(.024)}$	$\frac{8.0}{(.315)}$
ZV 25 K 10	$\frac{7.0}{(.276)}$	$\frac{4.5}{(.177)}$	$\frac{5.0}{(.197)}$	$\frac{0.6}{(.024)}$	$\frac{9.0}{(.354)}$
ZV 25 K 14	$\frac{8.0}{(.315)}$	$\frac{4.5}{(.177)}$	$\frac{5.0}{(.197)}$	$\frac{0.6}{(.024)}$	$\frac{12.0}{(.472)}$
ZV 25 K 20	$\frac{9.0}{(.354)}$	$\frac{4.5}{(.177)}$	$\frac{5.0}{(.197)}$	$\frac{0.6}{(.024)}$	$\frac{12.0}{(.472)}$
ZV 30 K 5	$\frac{6.0}{(.236)}$	$\frac{4.5}{(.177)}$	$\frac{5.0}{(.197)}$	$\frac{0.6}{(.024)}$	$\frac{7.0}{(.276)}$
ZV 30 K 7	$\frac{7.0}{(.276)}$	$\frac{4.5}{(.177)}$	$\frac{5.0}{(.197)}$	$\frac{0.6}{(.024)}$	$\frac{8.0}{(.315)}$
ZV 30 K 10	$\frac{7.0}{(.276)}$	$\frac{4.5}{(.177)}$	$\frac{5.0}{(.197)}$	$\frac{0.6}{(.024)}$	$\frac{9.0}{(.354)}$
ZV 30 K 14	$\frac{8.0}{(.315)}$	$\frac{4.5}{(.177)}$	$\frac{5.0}{(.197)}$	$\frac{0.6}{(.024)}$	$\frac{12.0}{(.472)}$
ZV 30 K 20	$\frac{9.0}{(.354)}$	$\frac{4.5}{(.177)}$	$\frac{5.0}{(.197)}$	$\frac{0.6}{(.024)}$	$\frac{12.0}{(.472)}$

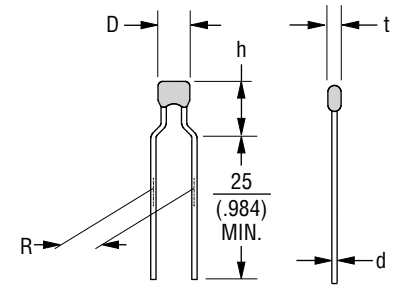

Size 5, 7, 10

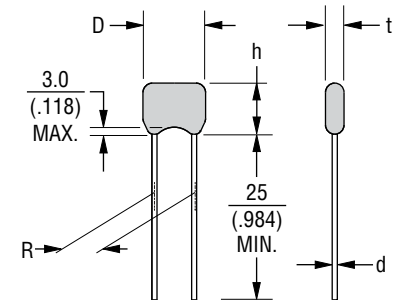

Size 14, 20

DIMENSIONS: $\frac{\text{MM}}{\text{(INCHES)}}$

Continued on next page

Specifications are subject to change without notice.

Users should verify actual device performance in their specific applications.

The products described herein and this document are subject to specific legal disclaimers as set forth on the last page of this document, and at www.bourns.com/docs/legal/disclaimer.pdf.

ZV Series – Low Voltage Leaded Style Varistors



Product Dimensions (Continued)

Model	D max.	t max.	R	d	h max.
ZV 35 K 5	$\frac{6.0}{(.236)}$	$\frac{4.5}{(.177)}$	$\frac{5.0}{(.197)}$	$\frac{0.6}{(.024)}$	$\frac{7.0}{(.276)}$
ZV 35 K 7	$\frac{7.0}{(.276)}$	$\frac{4.5}{(.177)}$	$\frac{5.0}{(.197)}$	$\frac{0.6}{(.024)}$	$\frac{8.0}{(.315)}$
ZV 35 K 10	$\frac{7.0}{(.276)}$	$\frac{4.5}{(.177)}$	$\frac{5.0}{(.197)}$	$\frac{0.6}{(.024)}$	$\frac{9.0}{(.354)}$
ZV 35 K 14	$\frac{8.0}{(.315)}$	$\frac{4.5}{(.177)}$	$\frac{5.0}{(.197)}$	$\frac{0.6}{(.024)}$	$\frac{12.0}{(.472)}$
ZV 35 K 20	$\frac{9.0}{(.354)}$	$\frac{4.5}{(.177)}$	$\frac{5.0}{(.197)}$	$\frac{0.6}{(.024)}$	$\frac{12.0}{(.472)}$
ZV 40 K 5	$\frac{6.0}{(.236)}$	$\frac{4.5}{(.177)}$	$\frac{5.0}{(.197)}$	$\frac{0.6}{(.024)}$	$\frac{7.0}{(.276)}$
ZV 40 K 7	$\frac{7.0}{(.276)}$	$\frac{4.5}{(.177)}$	$\frac{5.0}{(.197)}$	$\frac{0.6}{(.024)}$	$\frac{8.0}{(.315)}$
ZV 40 K 10	$\frac{7.0}{(.276)}$	$\frac{4.5}{(.177)}$	$\frac{5.0}{(.197)}$	$\frac{0.6}{(.024)}$	$\frac{9.0}{(.354)}$
ZV 40 K 14	$\frac{8.0}{(.315)}$	$\frac{4.5}{(.177)}$	$\frac{5.0}{(.197)}$	$\frac{0.6}{(.024)}$	$\frac{12.0}{(.472)}$
ZV 40 K 20	$\frac{9.0}{(.354)}$	$\frac{4.5}{(.177)}$	$\frac{5.0}{(.197)}$	$\frac{0.6}{(.024)}$	$\frac{12.0}{(.472)}$

DIMENSIONS: $\frac{\text{MM}}{\text{(INCHES)}}$

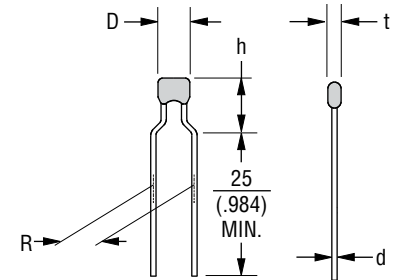

Size 5, 7, 10

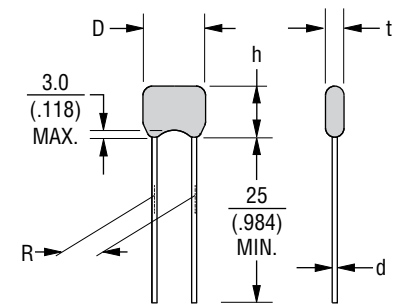

Size 14, 20

How to Order

ZV14K20RL1yy

Series Designator _____
 ZV = ZV Series

Maximum Continuous Working Voltage (V_{rms}) _____

V_n Tolerance _____
 K = $\pm 10\%$, L = $\pm 15\%$, M = $\pm 20\%$

Model Size (mm) _____
 • 5 • 14
 • 7 • 20
 • 10

Packaging _____
 R = Reel
 B = Bulk
 A = Ammo Pack (available only upon request)

Lead Style _____
 1 = Straight
 5 = Crimped

Special Requirements _____
 • yy

Typical Part Marking

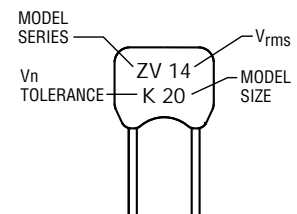

Instructions for Creating Orderable Part Number:

- 1) Start with base part number in characteristics table (example: ZV14K20).
- 2) Add Packaging: R (example part number becomes ZV14K20R).
- 3) Add Lead Style: L1 (example part number becomes ZV14K20RL1).
- 4) Part number can have no spaces or lower case letters.

Specifications are subject to change without notice.

Users should verify actual device performance in their specific applications.

The products described herein and this document are subject to specific legal disclaimers as set forth on the last page of this document, and at www.bourns.com/docs/legal/disclaimer.pdf.

ZV Series – Low Voltage Leaded Style Varistors



Protection Level

Model Size 5 (ZV 2 M 5 ~ ZV 40 K 5)

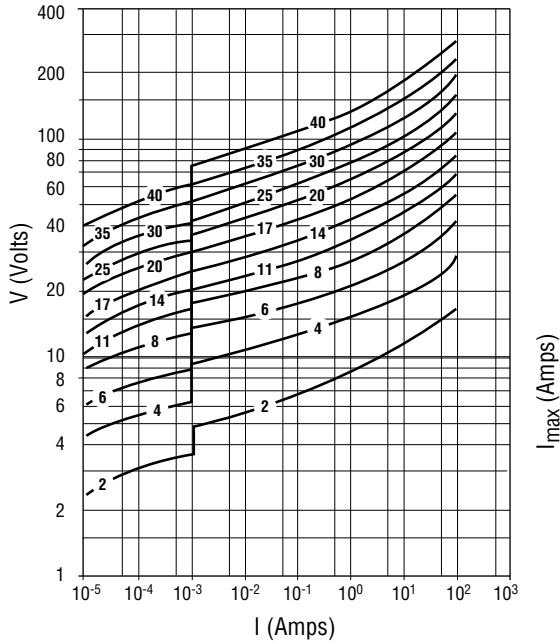

Pulse Rating Curves

Model Size 5 (ZV 2 M 5 ~ ZV 40 K 5)

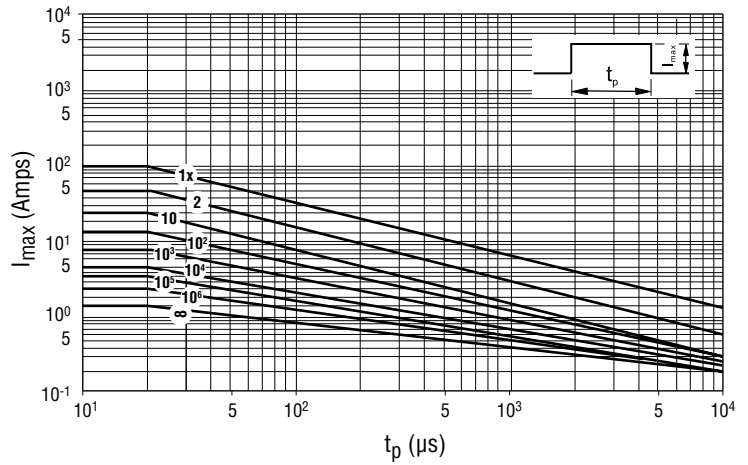

Model Size 7 (ZV 2 M 7 ~ ZV 40 K 7)

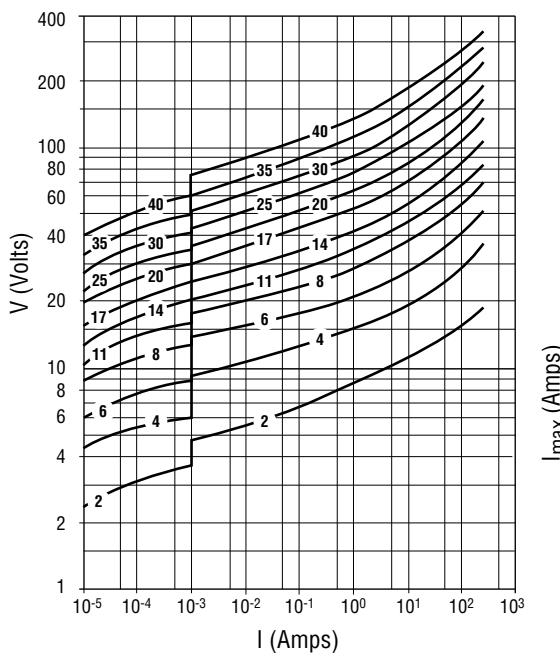

Model Size 7 (ZV 2 M 7 ~ ZV 40 K 7)

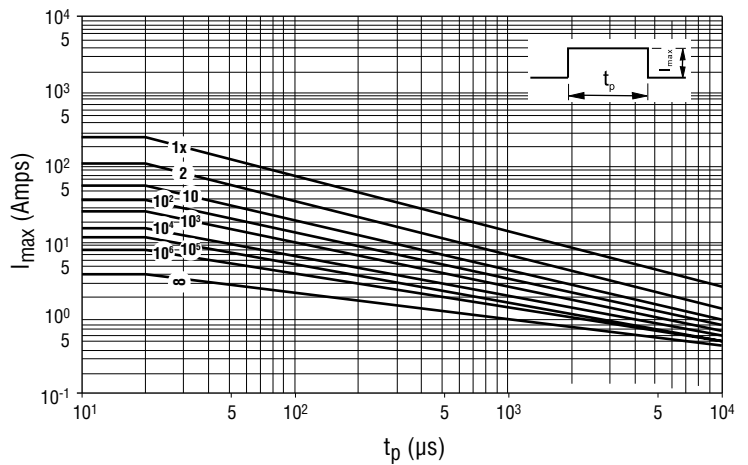

Specifications are subject to change without notice.

Users should verify actual device performance in their specific applications.

The products described herein and this document are subject to specific legal disclaimers as set forth on the last page of this document, and at www.bourns.com/docs/legal/disclaimer.pdf.

ZV Series – Low Voltage Leaded Style Varistors

BOURNS®

Protection Level

Model Size 10 (ZV 4 M 10 ~ ZV 40 K 10)

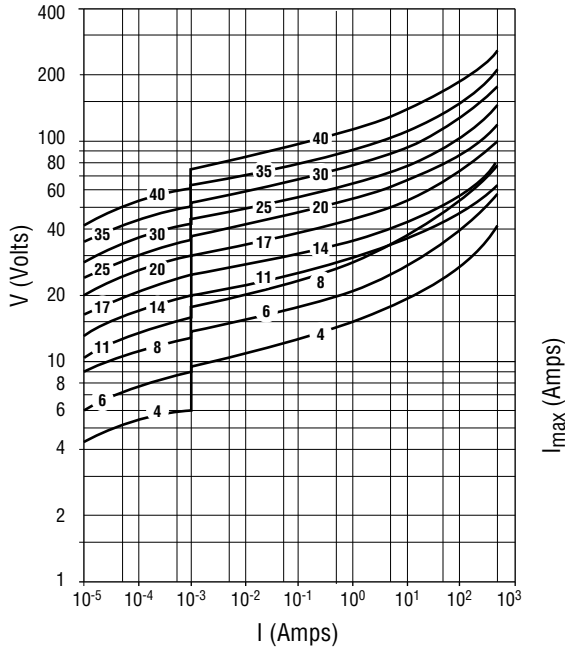

Model Size 14 (ZV 4 M 14 ~ ZV 40 K 14)

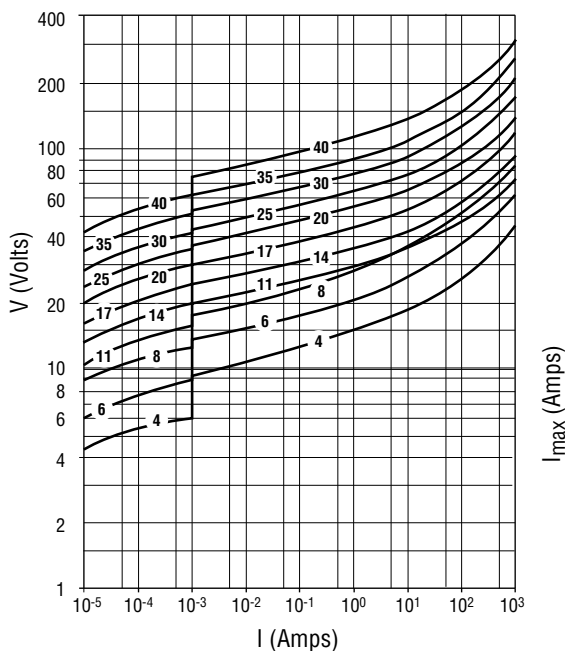

Pulse Rating Curves

Model Size 10 (ZV 4 M 10 ~ ZV 40 K 10)

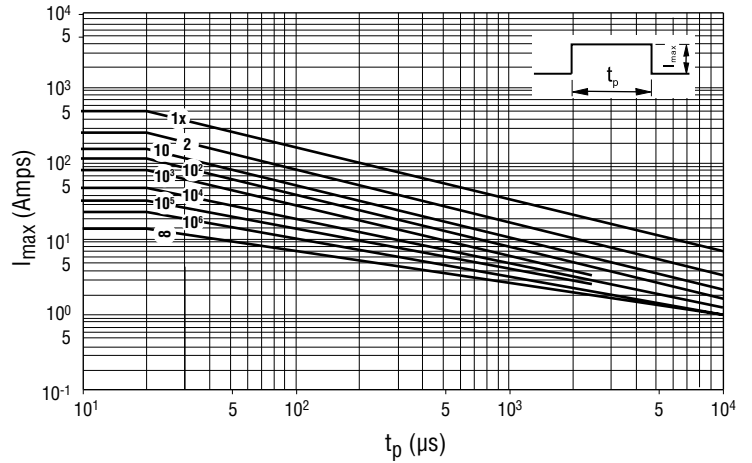

Model Size 14 (ZV 4 M 14 ~ ZV 40 K 14)

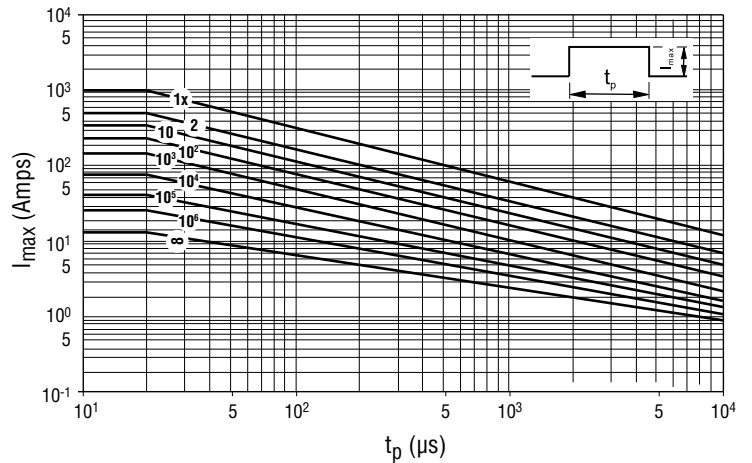

Specifications are subject to change without notice.

Users should verify actual device performance in their specific applications.

The products described herein and this document are subject to specific legal disclaimers as set forth on the last page of this document, and at www.bourns.com/docs/legal/disclaimer.pdf.

ZV Series – Low Voltage Leaded Style Varistors



Protection Level

Model Size 20 (ZV 4 M 20 ~ ZV 40 K 20)

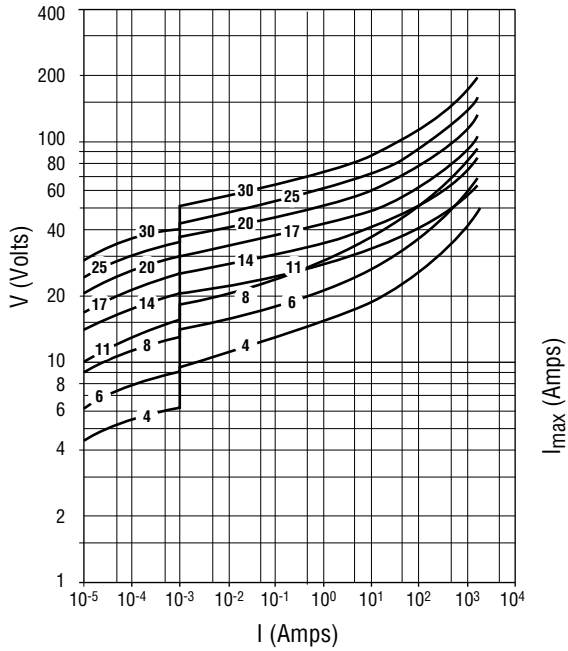

Pulse Rating Curves

Model Size 20 (ZV 4 M 20 ~ ZV 40 K 20)

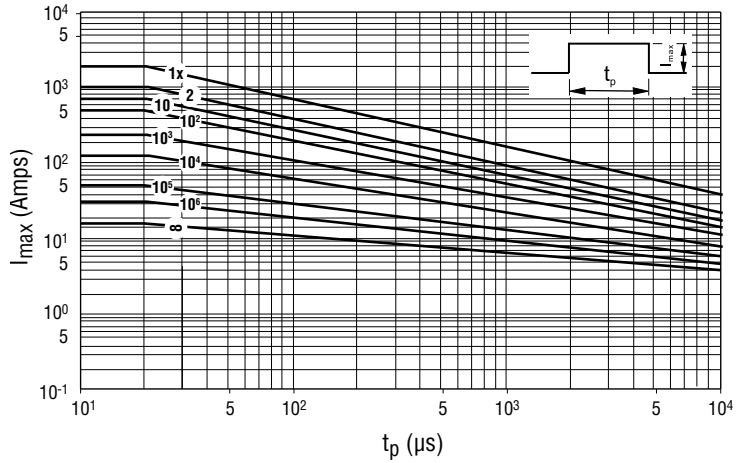

Specifications are subject to change without notice.

Users should verify actual device performance in their specific applications.

The products described herein and this document are subject to specific legal disclaimers as set forth on the last page of this document, and at www.bourns.com/docs/legal/disclaimer.pdf.

ZV Series – Low Voltage Leaded Style Varistors

BOURNS®

Packaging Specifications - Tape

Conforms to IES Publication 286-2 Ed. 3: 2008-03

Dimension R = 5 mm

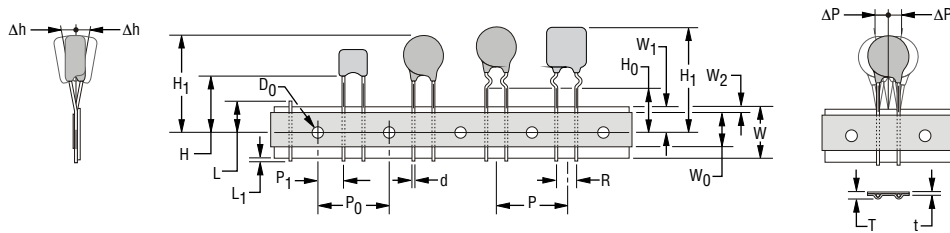

Dimensions on Next Page

Dimension R = 7.5 mm & 10 mm

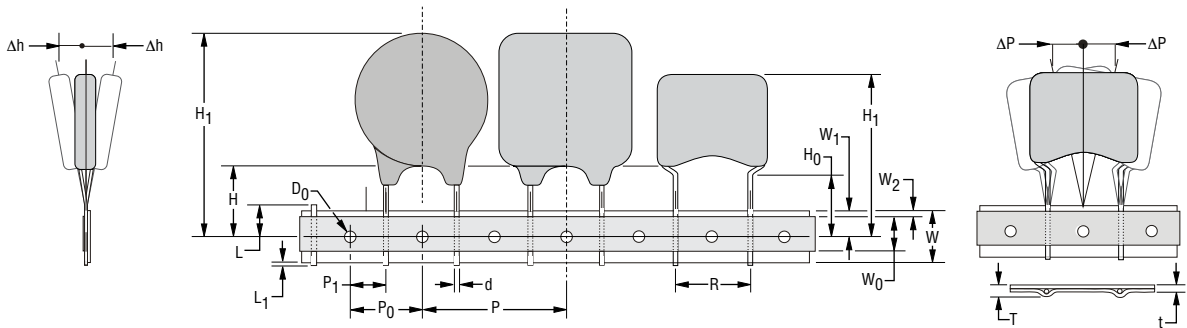

Dimensions on Next Page

Reel

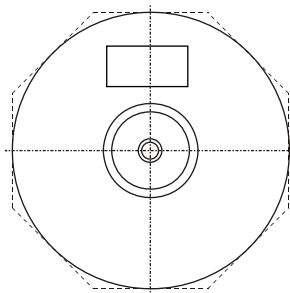
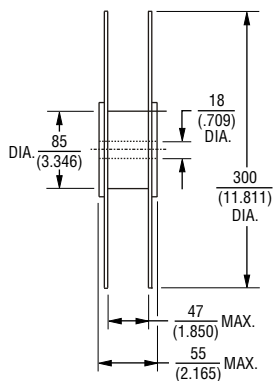

DIMENSIONS: $\frac{\text{MM}}{\text{(INCHES)}}$

Ammo Pack (Available upon Special Request)

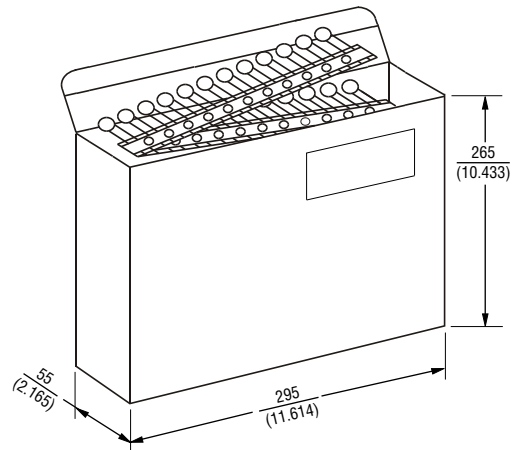

Specifications are subject to change without notice.

Users should verify actual device performance in their specific applications.

The products described herein and this document are subject to specific legal disclaimers as set forth on the last page of this document, and at www.bourns.com/docs/legal/disclaimer.pdf.

ZV Series – Low Voltage Leaded Style Varistors

BOURNS®

Packaging Specifications - Tape (Continued)

Symbol	Parameter	Model Size				
		5	7	10	14	20
W	Carrier tape width	$\frac{18 + 1.0/-0.5}{(.709 + .039/-0.020)}$				
W ₀	Hold down tape width	$\frac{5}{(.197)}$ MIN.				
W ₁	Sprocket hole position	$\frac{9 + 0.75/-0.5}{(.354 + .030/-0.020)}$				
W ₂	Distance between the upper edges of the carrier tape and hold down tape	$\frac{3}{(.118)}$ MAX.				
T	Total tape thickness	$\frac{1.5}{(.059)}$ MAX.		$\frac{1.7}{(.067)}$ MAX.		$\frac{1.9}{(.075)}$ MAX.
t	Tape thickness	$\frac{0.9}{(.035)}$ MAX.				
P	Pitch of component	$\frac{12.7 \pm 1.0}{(.500 \pm .039)}$			$\frac{25.4 \pm 1.0}{(1.00 \pm .039)}$	
P ₀	Feed hole pitch	$\frac{12.7 \pm 0.3}{(.500 \pm .012)}$				
P ₁	Feed hole center to pitch	$\frac{3.85 \pm 0.7}{(.152 \pm .028)}$		$\frac{8.95 \pm 0.7}{(.352 \pm .028)}$		$\frac{7.7 \pm 0.7}{(.303 \pm .028)}$
R	Lead spacing	$\frac{5 + 0.5/-0.2}{(.197 + .020/-0.008)}$		$\frac{7.5 + 0.5/-0.2}{(.295 + .020/-0.008)}$		$\frac{10 + 0.5/-0.2}{(.394 + .020/-0.008)}$
ΔP	Component alignment	$\frac{\pm 1.3}{(\pm .051)}$ MAX.				
Δh	Component alignment	$\frac{\pm 2}{(\pm .079)}$ MAX.				
d	Wire diameter	$\frac{0.6}{(.024)}$ MAX.		$\frac{0.8}{(.031)}$ MAX.		$\frac{1.0}{(.039)}$ MAX.
D ₀	Feed hold diameter	$\frac{4 \pm 0.2}{(.157 \pm .008)}$				
H	Height from tape center to component base	$\frac{18 + 2.0/-0.0}{(.709 + .079/0)}$				
H ₀	Seating plane height	$\frac{16 \pm 0.5}{(.630 \pm .020)}$				
H ₁	Component height	$\frac{32.2}{(1.268)}$ MAX.		$\frac{46.5}{(1.831)}$ MAX.		
L	Protrusion - cut out	$\frac{11}{(.433)}$ MAX.				
L ₁	Protrusion - cut off	$\frac{0.5}{(.020)}$ MAX.				

DIMENSIONS: $\frac{\text{MM}}{\text{(INCHES)}}$

Specifications are subject to change without notice.

Users should verify actual device performance in their specific applications.

The products described herein and this document are subject to specific legal disclaimers as set forth on the last page of this document, and at www.bourns.com/docs/legal/disclaimer.pdf.

ZV Series – Low Voltage Leaded Style Varistors

BOURNS®

Packaging Quantities

Bulk

V	5	7	10	14	20
2	1500	1500	1500	1000	1000
4	1500	1500	1500	1000	1000
6	1500	1500	1500	1000	1000
8	1500	1500	1500	1000	1000
11	1500	1500	1500	1000	1000
14	1500	1500	1500	1000	1000
17	1500	1500	1500	1000	1000
20	1500	1500	1500	1000	1000
25	1500	1500	1500	1000	1000
30	1500	1500	1500	1000	1000
35	1500	1500	1500	1000	1000
40	1500	1500	1500	1000	1000

Reel

V	5	7	10	14	20
2	1500	1500	1500	1500	1500
4	1500	1500	1500	1500	1500
6	1500	1500	1500	1500	1500
8	1500	1500	1500	1500	1500
11	1500	1500	1500	1500	1500
14	1500	1500	1500	1500	1500
17	1500	1500	1300	1500	1500
20	1500	1500	1300	1500	1500
25	1300	1300	1300	1500	1500
30	1300	1300	1300	1500	1500
35	1300	1300	1300	1500	1500
40	1300	1300	1300	1500	1500

Specifications are subject to change without notice.

Users should verify actual device performance in their specific applications.

The products described herein and this document are subject to specific legal disclaimers as set forth on the last page of this document, and at www.bourns.com/docs/legal/disclaimer.pdf.

ZV Series – Low Voltage Leaded Style Varistors

BOURNS®

Assembly Recommendations for Through-Hole Components

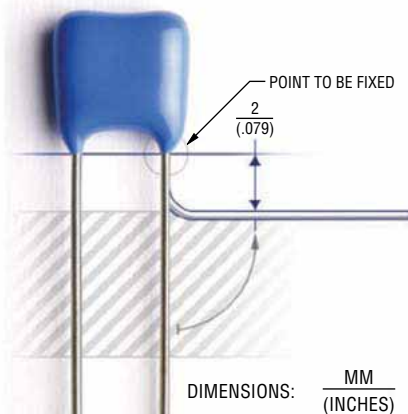

Very often before soldering through-hole components, their leads get bent. It is important not to damage the components during lead bending. Damage most commonly incurred during bending is cracks in epoxy parts, which can lead to increased humidity sensitivity of a component and, consequentially, a shorter lifetime.

In order to avoid epoxy damage, it is necessary to:

- fix the most sensitive point (epoxy parts) of a component body
- bend the wire at least 2 mm below the end of epoxy parts

Other potential damage to a component which can lead to component failure or a shorter lifetime is thermal shock during manual soldering with a soldering iron. This can occur when a soldering iron is placed too close to one point of the component body and it happens most often when the solder joint is too close to the varistor body.

Resistance to Soldering Heat

In the case of automatic wave soldering, it is important to provide sufficient resistance to soldering heat. In order to prevent any potential problems, internal standards were introduced for testing the resistance to soldering heat of through-hole components: 300 °C, 10 seconds.

Pb-free Wave Soldering Profile Recommendations

Recommended soldering profiles for all above components are in accordance with JEDEC standard curves (J-STD-020D) and are, therefore, compatible with the Pb-free process.

Lead-free Wave Soldering Profile - Pb-free wave profile requirements for soldering heat resistance of components

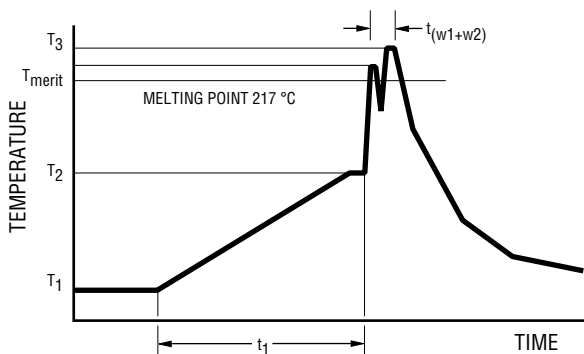

Parameter	Symbol	Specification
Preheating temperature gradient		4 °C/sec. max.
Preheating time	t_1	2 to 5 min.
Min. preheating temperature	T_1	130 °C
Max. preheating temperature	T_2	180 °C
Melting temperature/point	T_{meltv}	217 °C
Time in wave soldering phase (w_1+w_2)	t_{w1+w2}	10 sec.
Max. wave temperature (w_1+w_2)	T_s	265 °C +0/-5 °C
Cooling temperature gradient		6° C/sec. max.
Temperature jump from T_2 to T_3 (w_1)	$T_{3(w1)} - T_2$	120 °C max
Time from 25 °C to T_3 (wave temperature)		8 min. max.

Specifications are subject to change without notice.

Users should verify actual device performance in their specific applications.

The products described herein and this document are subject to specific legal disclaimers as set forth on the last page of this document, and at www.bourns.com/docs/legal/disclaimer.pdf.

ZV Series – Low Voltage Leaded Style Varistors



Terminology

Term	Symbol	Definition
Rated AC Voltage	V_{rms}	Maximum continuous sinusoidal AC voltage (<5 % total harmonic distortion) which may be applied to the component under continuous operation conditions at +25 °C
Rated DC Voltage.....	V_{dc}	Maximum continuous DC voltage (<5 % ripple) which may be applied to the component under continuous operating conditions at +25 °C
Supply Voltage.....	V	The voltage by which the system is designated and to which certain operating characteristics of the system are referred; $V_{rms} = 1.1 \times V$
Leakage Current.....	I_{dc}	The current passing through the varistor at V_{dc} and at +25 °C or at any other specified temperature
Varistor Voltage	V_n	Voltage across the varistor measured at a given reference current (I_n)
Reference Current.....	I_n	Reference current = 1 mA DC
Clamping Voltage	V_c	The peak voltage developed across the varistor under standard atmospheric conditions, when passing an 8/20 μs class current pulse
Protection Level		
Class Current.....	I_c	A peak value of current which is 1/10 of the maximum peak current for 100 pulses at two per minute for the 8/20 μs pulse
Voltage Clamping Ratio.....	V_c/V_{app}	A figure of merit measure of the varistor clamping effectiveness as defined by the symbols V_c/V_{app} , where ($V_{app} = V_{rms}$ or V_{dc})
Jump Start Transient	V_{jump}	The jump start transient results from the temporary application of an overvoltage in excess of the rated battery voltage. The circuit power supply may be subjected to a temporary overvoltage condition due to the voltage regulation failing or it may be deliberately generated when it becomes necessary to boost start the car.
Rated Single Pulse	W_{max}	Energy which may be dissipated for a single 10/1000 μs pulse of a maximum rated current, with rated AC voltage or rated DC voltage also applied, without causing device failure
Transient Energy		
Load Dump Transient	WLD	Load Dump is a transient which occurs in automotive environments. It is an exponentially decaying positive voltage which occurs in the event of a battery disconnect while the alternator is still generating charging current with other loads remaining on the alternator circuit at the time of battery disconnect.
Rated Peak Single Pulse.....	I_{max}	Maximum peak current which may be applied for a single 8/20 μs pulse, with rated line voltage also applied, without causing device failure
Transient Current		
Rated Transient Average	P	Maximum average power which may be dissipated due to a group of pulses occurring within a specified isolated time period, without causing device failure at 25 °C
Power Dissipation		
Capacitance.....	C	Capacitance between two terminals of the varistor measured @ 1 kHz
Non-linearity Exponent	α	A measure of varistor nonlinearity between two given operating currents, I_n and I_1 as described by $I = k V \exp(a)$, where: - k is a device constant, - $I_1 < I < I_n$ and - $a \log(I_1/I_n) / \log(V_1/V_n) = 1 / \log(V_1/V_n)$, where: - I_r is reference current (1 mA) and V_n is varistor voltage - $I_1 = 10 I_n$, V_1 is the voltage measured at I_1
Response Time.....	t_r	The time lag between application of a surge and varistor's "turn-on" conduction action
Varistor Voltage Temperature	TC	$(V_n @ 85^\circ C - V_n @ 25^\circ C) / (V_n @ 25^\circ C) \times 60^\circ C \times 100$
Coefficient		
Insulation Resistance	IR.....	Minimum resistance between shorted terminals and varistor surface
Isolation Voltage		The maximum peak voltage which may be applied under continuous operating conditions between the varistor terminations and any conducting mounting surface
Operating Temperature		The range of ambient temperature for which the varistor is designed to operate continuously as defined by the temperature limits of its climatic category
Climatic Category	LCT/UCT/DHD	LCT & UCT = Lower and Upper Category Temperature - the minimum and maximum ambient temperatures for which a varistor has been designed to operate continuously. DHD = Dump Heat Test Duration
Storage Temperature		Storage temperature range without voltage applied
Current/Energy Derating.....		Derating of maximum values when operated above UCT

REV. B 11/20

Specifications are subject to change without notice.

Users should verify actual device performance in their specific applications.

The products described herein and this document are subject to specific legal disclaimers as set forth on the last page of this document, and at www.bourns.com/docs/legal/disclaimer.pdf.

This legal disclaimer applies to purchasers and users of Bourns® products manufactured by or on behalf of Bourns, Inc. and its affiliates (collectively, "Bourns").

Unless otherwise expressly indicated in writing, Bourns® products and data sheets relating thereto are subject to change without notice. Users should check for and obtain the latest relevant information and verify that such information is current and complete before placing orders for Bourns® products.

The characteristics and parameters of a Bourns® product set forth in its data sheet are based on laboratory conditions, and statements regarding the suitability of products for certain "typical" applications are based on Bourns' knowledge of typical requirements in generic applications. Bourns assumes that "typical" applications include failsafe/backup features to address critical risks to users and are designed to allow rework of Bourns® product to avoid scrap of a device solely due to malfunctioning Bourns® product. The characteristics and parameters of a Bourns® product in a user application may vary from the data sheet characteristics and parameters due to (i) the combination of the Bourns® product with other components in the user's application, or (ii) the environment of the user application itself. The characteristics and parameters of a Bourns® product also can and do vary in different applications and actual performance may vary over time. Thus, users should always verify the actual performance of the Bourns® product in their specific devices and applications and make their own independent judgments regarding the suitability of Bourns® product and the amount of additional test margin to design into their device or application to compensate for differences between laboratory and real-world conditions.

Unless Bourns has explicitly designated an individual Bourns® product as meeting the requirements of a particular industry standard (e.g., IATF 16949) or a particular qualification (e.g., UL listed or recognized), Bourns is not responsible for any failure of an individual Bourns® product to meet the requirements of such industry standard or particular qualification even if such industry standard or qualification is a "state of art". Users of Bourns® products are responsible for ensuring compliance with safety-related requirements and standards applicable to their devices or applications.

Bourns® products are not recommended, authorized or intended for use in applications where failure or malfunction may result in personal injury, death, or severe property or environmental damage, such as without limitation nuclear, life-critical medical and certain automotive and aviation applications. Except as set forth in the bullet points below or unless expressly and specifically approved in writing on a case-by-case basis by an authorized Bourns' representative, use of any Bourns® products in such unauthorized high-risk applications is at the user's sole risk.

- Bourns considers implantable/invasive devices and devices/procedures designed as life-supporting or life-sustaining by the U.S. Food and Drug Administration or equivalent organizations outside of the United States as "life-critical" medical applications. Bourns expressly identifies those Bourns® standard products that are suitable for use in typical medical applications that are not life-critical in its publication entitled "Bourns Medical Grade Component Guide."
- Bourns expressly identifies those Bourns® standard products that are suitable for use in typical automotive applications associated with any Automate Safety Integrity Level (ASIL) in its publication entitled "Bourns Automotive Grade Component Guide." Bourns' designation of Bourns® product as compliant with the AEC-Q standard does not by itself mean that Bourns has approved such product for use in an automotive application.
- Bourns expressly identifies Bourns® standard products that are suitable for use in the typical aviation applications/systems requiring System Design Assurance Level (RTCA DO-254 DAL) of C, D or E in its publication entitled "Bourns Civilian Aerospace/Aviation Grade Component Guide." Bourns does not test its products for compliance with United States Federal Aviation Administration standards or any other generally equivalent governmental organization standard applicable to products designed or manufactured for use in aviation applications. Use of Bourns® standard components in aviation applications associated with RTCA DO-254 DAL A or B without proper approval noted above shall be at the user's sole risk.
- Bourns will review and authorize on a case-by-case basis the use of Bourns® standard products which are at least AEC-Q compliant in space-related civil applications (rockets, satellites) with a negotiated cross-waiver and indemnity agreement.

The use and level of testing applicable to Bourns® custom products shall be negotiated on a case-by-case basis by Bourns and the user for which such Bourns® custom products are specially designed. Absent a written agreement between Bourns and the user regarding the use and level of such testing, the above provisions applicable to Bourns® standard products shall also apply to such Bourns® custom products.

Use of Bourns® products or Bourns' technology in military/defense applications must be reviewed with Bourns for compliance with applicable export control laws and embargoes. Users shall not sell, transfer, export or re-export (which includes transfers within a country) any Bourns® products or technology or technical data for use in activities which involve the design, development, production, use or stockpiling of nuclear, chemical or biological weapons or missiles, nor shall they use Bourns® products or technology or technical data in any facility which engages in activities relating to such devices. Further, Bourns® products and Bourns' technology and technical data may not under any circumstance be exported or re-exported to countries subject to international sanctions or embargoes. Bourns® products and technology may not, without prior authorization from Bourns and/or the Government of a country where such product/technology is designed and/or manufactured, be resold, transferred, or re-exported (including within the same country) to any party not eligible to receive commodities, software, and technical data originating in such country.

To the maximum extent permitted by applicable law, Bourns disclaims (i) any and all liability for special, punitive, consequential, incidental or indirect damages or lost revenues or lost profits, and (ii) any and all implied warranties (those not based on parameters specified in Bourns' data sheets and/or specifications), including implied warranties of fitness for particular purpose, non-infringement and merchantability.

For your convenience, copies of this Legal Disclaimer Notice with German, Spanish, Japanese, Traditional Chinese and Simplified Chinese bilingual versions are available at:

Web Page: <https://www.bourns.com/legal/disclaimers-terms-and-policies>

PDF: <https://www.bourns.com/docs/Legal/disclaimer.pdf>