

Features

- Rugged 3-electrode BUG-less GDT
- Balanced TRIGARD®
- Self-resetting low resistance sneak current protection with Bourns® PPTC resistors
- Patented Switch-Grade Fail-Short device
- Quick response and high energy handling
- UL Listed per UL497
- Sealed option for harsh environments



This series is obsolete and not recommended for new designs.

2440 Series 5-Pin Surge Protector

Bourns® 5-Pin Model 2440 series is a new generation of Bourns® telecommunications protectors for superior performance and long life. The 2440 Series protector provides highly reliable overvoltage and self-resetting sneak current protection for copper pair voice-band and high speed data circuits. Bourns' high-efficiency balanced Gas Discharge Tube (GDT) is UL approved for use without a Back-Up Gap (BUG). Its Switch-Grade Fail-Short mechanism ensures superior thermal protection with fast acting, highly reliable response to thermal overload conditions. This combined technology provides lower capacitance, higher reliability and long life. Bourns® PPTC Resistors are used for sneak current protection, providing reliable and self-resetting performance with less than four ohms of resistance.

Bourns® 2440 protectors can be used universally for broadband voice and data circuits including ADSL, ADSL2+, VDSL, VDSL2 and high-speed ethernet. The 2440 Series is an innovative, reliable and effective choice for 5-pin protection of copper pair circuits.

Characteristics

Tested per UL 497, CSA C22.2, Telcordia GR 974, 1361 and SBC SR 5165.

DC Breakdown	280-420 V
AC Breakdown @ 60 Hz	280-420 V
Impulse Breakdown	
100 V/μs.....	625 V
1000 V/μs.....	875 V
Insulation Resistance @ 100 Vdc	> 1 GΩ
Insertion Loss @ 100 MHz	Exceeds CAT5 1
Return Loss @ 100 MHz	Exceeds CAT5 1
Capacitance Tip to Ring @ 1 MHz	< 1.25 pF typical
Capacitance Tip or Ring to Ground @ 1 MHz	< 2.50 pF typical
Impulse Reset ²	
52 V, 260 mA	< 10 ms
135 V, 200 mA.....	< 10 ms
150 V, 200 mA.....	< 150 ms
Impulse Life Characteristics (Tip and Ring to Ground Simultaneously)	
10 A, 10/1000 μs.....	> 3000 operations
100 A, 10/1000 μs.....	> 300 operations
300 A, 10/1000 μs.....	> 100 operations
500 A, 10/1000 μs.....	> 400 operations ³
2,000 A, 10/250 μs	> 25 operations
5,000 A, 20/100 μs.....	> 2 operations
20,000 A, 8/20 μs	> 1 operation
AC Life Characteristics (Tip and Ring to Ground Simultaneously)	
0.5 A rms continuous.....	> 30 seconds
1 A rms, 1 second, 600 ft. cable.....	> 60 operations
1 A rms, 1 second, 1 mile cable	> 60 operations
10 A rms, 1 second	> 5 operations
65 A rms, 11 cycles	> 1 operation ³
120 A rms, 0.1 second	1 operation
High Current Capability and Thermal Operation (T/R to Ground)	> 30 Arms, simultaneously
Storage and Operating Temperature	-55 to +85 °C
Sneak Current Characteristics	
Resistance (No Heat Coil Inductance).....	< 4 ohms
Transition Current @ -40 °C (800 mA), +20 °C (540 mA), +65 °C (300 mA)	< 210 seconds
Rated Current @ -40 °C (100 mA), +20 °C (100 mA), +65 °C (100 mA)	> 3 hours
Impulse Life 10 x 1000 μs @ -40 °C, +20 °C, +65 °C	25 A ELTGS

Telcordia analyzed for controlled (non-sealed) and uncontrolled high exposure (sealed) environments per GR 974 and SBC SR 5165. Please refer to Telcordia Analysis Report DA-1547 Volumes 1 and 2.

Notes:

¹ Tested according to Category 5 requirements.

² Network applied.

³ Per Rus PE 80.

Line to Line voltage is approximately 1.8 to 2 times the stated Line to Ground breakdown voltage.



WARNING
Cancer and Reproductive Harm
www.P65Warnings.ca.gov

Specifications are subject to change without notice. Users should verify actual device performance in their specific applications. The products described herein and this document are subject to specific legal disclaimers as set forth on the last page of this document, and at www.bourns.com/docs/legal/disclaimer.pdf

Features (Continued)

- Meets test requirements of GR 974, GR 1361, SBC SR 5165 and RUS PE-80
- Telcordia Analysis report DA-1547
- Test point access option
- Ideal for high-speed networks in high-exposure environments
- Solid brass, gold-plated pins

2440 Series 5-Pin Surge Protector

BOURNS®

Product Dimensions

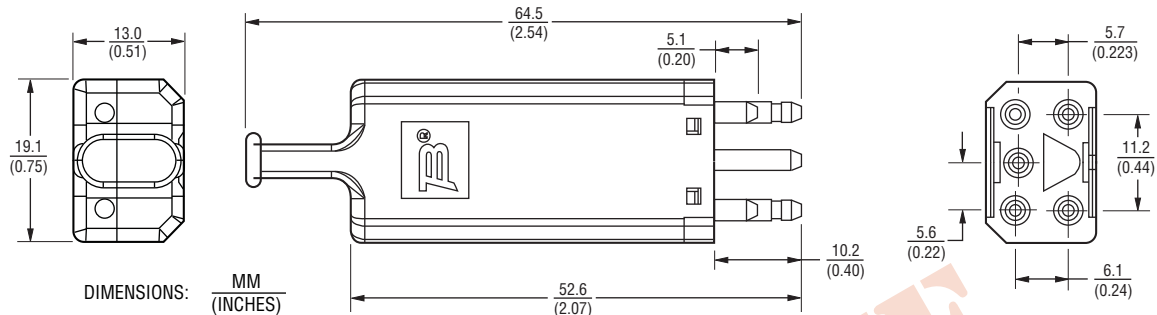

Schematic

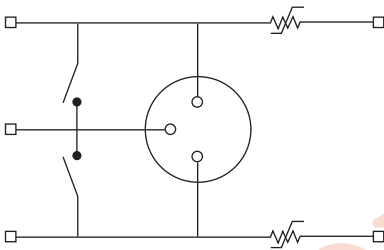

How To Order

2440 - 4 x - x - xx

Model Number Designator _____

Overcurrent Protection _____

Housing Color _____

- 1 = Black
- 3 = Red
- 6 = Blue
- 7 = Violet
- 9 = Orange
- 10 = Yellow

Pin Plating _____

- G = Gold Plated
- N = Tin Plated (Ground pin is tin plated on all models)

Housing Options _____

- S = Sealed
- T = Test Points
- ST = Sealed and Test Points

Examples:

- 2440-41-G-T = Black housing, 4 ohm self-resetting, gold-plated pins, test points
- 2440-43-N = Red housing, 4 ohm self-resetting, tin-plated pins, no test points

BOURNS®

Asia-Pacific: Tel: +886-2 2562-4117 • Email: asiacus@bourns.com

EMEA: Tel: +36 88 885 877 • Email: eurocus@bourns.com

The Americas: Tel: +1-951 781-5500 • Email: americus@bourns.com

www.bourns.com

REV. F 10/25

Specifications are subject to change without notice.

Users should verify actual device performance in their specific applications.

The products described herein and this document are subject to specific legal disclaimers as set forth on the last page of this document, and at www.bourns.com/docs/legal/disclaimer.pdf.

This legal disclaimer applies to purchasers and users of Bourns® products manufactured by or on behalf of Bourns, Inc. and its affiliates (collectively, “Bourns”).

Unless otherwise expressly indicated in writing, Bourns® products and data sheets relating thereto are subject to change without notice. Users should check for and obtain the latest relevant information and verify that such information is current and complete before placing orders for Bourns® products.

The characteristics and parameters of a Bourns® product set forth in its data sheet are based on laboratory conditions, and statements regarding the suitability of products for certain types of applications are based on Bourns’ knowledge of typical requirements in generic applications. The characteristics and parameters of a Bourns® product in a user application may vary from the data sheet characteristics and parameters due to (i) the combination of the Bourns® product with other components in the user’s application, or (ii) the environment of the user application itself. The characteristics and parameters of a Bourns® product also can and do vary in different applications and actual performance may vary over time. Users should always verify the actual performance of the Bourns® product in their specific devices and applications, and make their own independent judgments regarding the amount of additional test margin to design into their device or application to compensate for differences between laboratory and real world conditions.

Unless Bourns has explicitly designated an individual Bourns® product as meeting the requirements of a particular industry standard (e.g., ISO/TS 16949) or a particular qualification (e.g., UL listed or recognized), Bourns is not responsible for any failure of an individual Bourns® product to meet the requirements of such industry standard or particular qualification. Users of Bourns® products are responsible for ensuring compliance with safety-related requirements and standards applicable to their devices or applications.

Bourns® products are not recommended, authorized or intended for use in nuclear, lifesaving, life-critical or life-sustaining applications, nor in any other applications where failure or malfunction may result in personal injury, death, or severe property or environmental damage. Unless expressly and specifically approved in writing by two authorized Bourns representatives on a case-by-case basis, use of any Bourns® products in such unauthorized applications might not be safe and thus is at the user’s sole risk. Life-critical applications include devices identified by the U.S. Food and Drug Administration as Class III devices and generally equivalent classifications outside of the United States.

Bourns expressly identifies those Bourns® standard products that are suitable for use in automotive applications on such products’ data sheets in the section entitled “Applications.” Unless expressly and specifically approved in writing by two authorized Bourns representatives on a case-by-case basis, use of any other Bourns® standard products in an automotive application might not be safe and thus is not recommended, authorized or intended and is at the user’s sole risk. If Bourns expressly identifies a sub-category of automotive application in the data sheet for its standard products (such as infotainment or lighting), such identification means that Bourns has reviewed its standard product and has determined that if such Bourns® standard product is considered for potential use in automotive applications, it should only be used in such sub-category of automotive applications. Any reference to Bourns® standard product in the data sheet as compliant with the AEC-Q standard or “automotive grade” does not by itself mean that Bourns has approved such product for use in an automotive application.

Bourns® standard products are not tested to comply with United States Federal Aviation Administration standards generally or any other generally equivalent governmental organization standard applicable to products designed or manufactured for use in aircraft or space applications. Bourns expressly identifies Bourns® standard products that are suitable for use in aircraft or space applications on such products’ data sheets in the section entitled “Applications.” Unless expressly and specifically approved in writing by two authorized Bourns representatives on a case-by-case basis, use of any other Bourns® standard product in an aircraft or space application might not be safe and thus is not recommended, authorized or intended and is at the user’s sole risk.

The use and level of testing applicable to Bourns® custom products shall be negotiated on a case-by-case basis by Bourns and the user for which such Bourns® custom products are specially designed. Absent a written agreement between Bourns and the user regarding the use and level of such testing, the above provisions applicable to Bourns® standard products shall also apply to such Bourns® custom products.

Users shall not sell, transfer, export or re-export any Bourns® products or technology for use in activities which involve the design, development, production, use or stockpiling of nuclear, chemical or biological weapons or missiles, nor shall they use Bourns® products or technology in any facility which engages in activities relating to such devices. The foregoing restrictions apply to all uses and applications that violate national or international prohibitions, including embargos or international regulations. Further, Bourns® products and Bourns technology and technical data may not under any circumstance be exported or re-exported to countries subject to international sanctions or embargoes. Bourns® products may not, without prior authorization from Bourns and/or the U.S. Government, be resold, transferred, or re-exported to any party not eligible to receive U.S. commodities, software, and technical data.

To the maximum extent permitted by applicable law, Bourns disclaims (i) any and all liability for special, punitive, consequential, incidental or indirect damages or lost revenues or lost profits, and (ii) any and all implied warranties, including implied warranties of fitness for particular purpose, non-infringement and merchantability.

For your convenience, copies of this Legal Disclaimer Notice with German, Spanish, Japanese, Traditional Chinese and Simplified Chinese bilingual versions are available at:

Web Page: <http://www.bourns.com/legal/disclaimers-terms-and-policies>

PDF: <http://www.bourns.com/docs/Legal/disclaimer.pdf>