

3324 - 4mm Square Trimming Potentiometer

BOURNS®

Packaging Specifications

TAPE

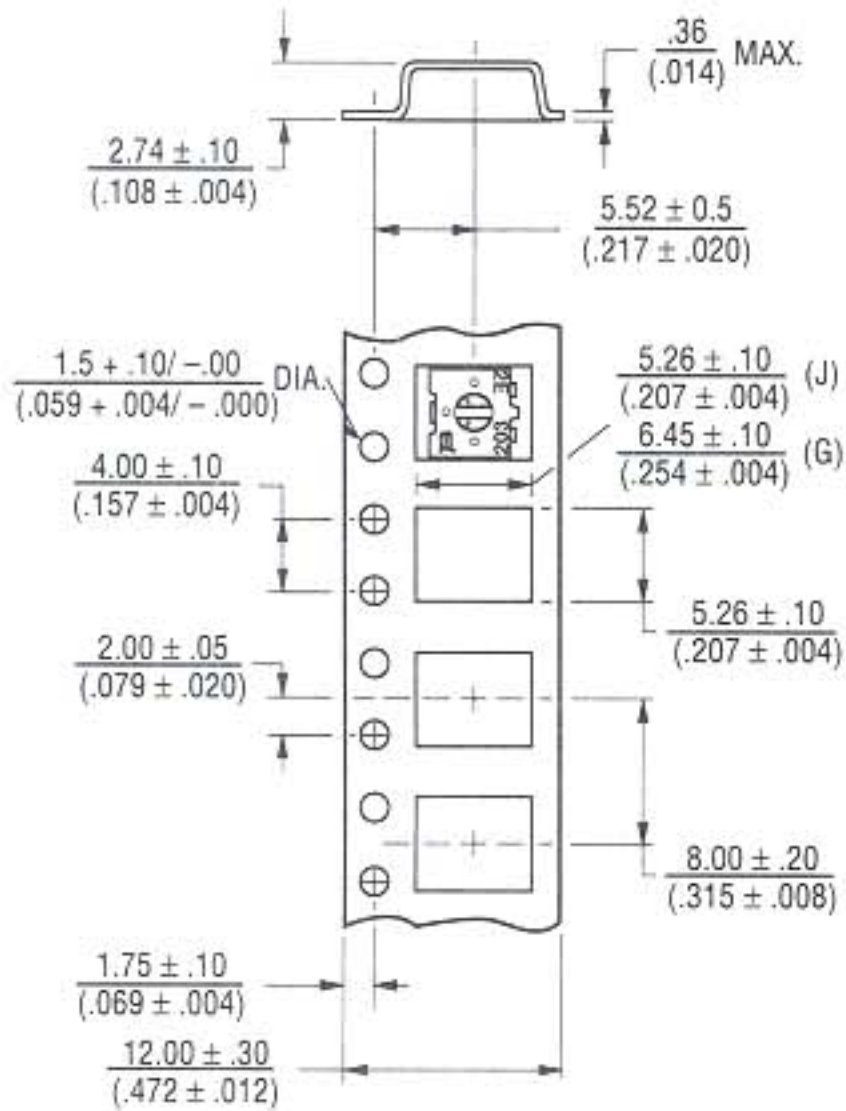

Standard Resistance Table

Resistance (Ohms)	Part Marking Code	Resistance Code
10	A1	100
20	21	200
50	51	500
100	A2	101
200	22	201
500	52	501
1,000	A3	102
2,000	23	202
5,000	53	502
10,000	A4	103
20,000	24	203
50,000	54	503
100,000	A5	104
200,000	25	204
500,000	55	504
1,000,000	A6	105
2,000,000	26	205

Popular values listed in boldface. Special resistances available.

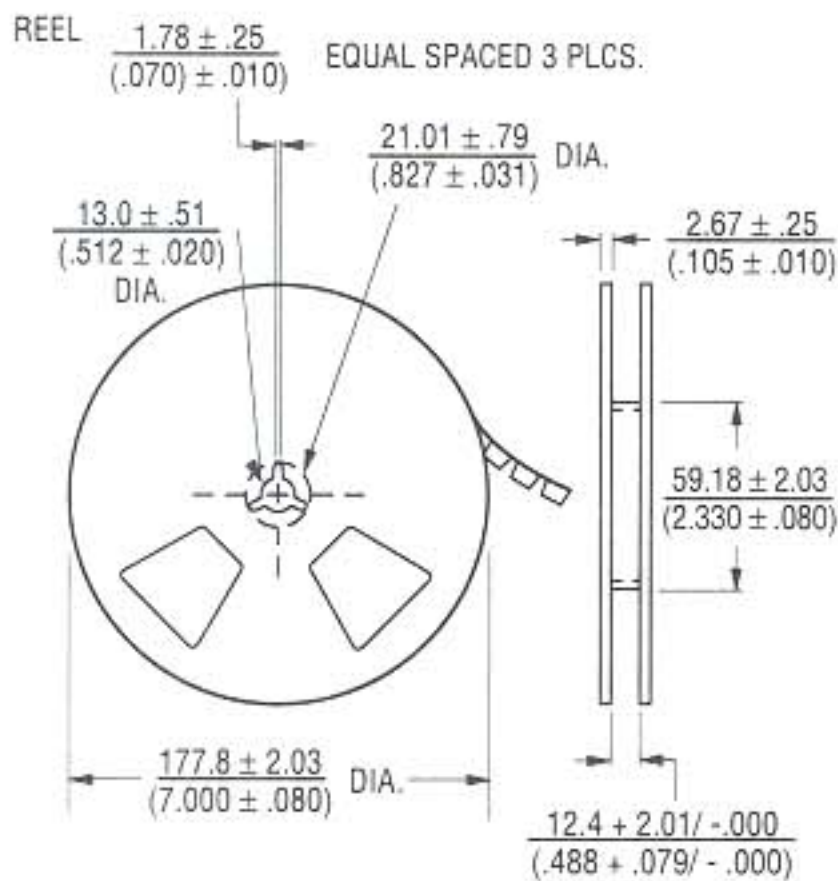

Meets EIA specification 481.

OBSOLETE 1998

TOLERANCES: ± 0.25 (.010) EXCEPT WHERE NOTED

DIMENSIONS ARE: METRIC
(INCHES)