

Features

- Optimizes data transmission in ECL systems through proper termination between drivers and receivers
- Minimizes overshoot, undershoot, and ringing while increasing noise immunity
- Provides decoupling capacitors
- RoHS compliant*



The 800 Series is obsolete, and not recommended for new designs.

For information on ECL Terminators, download Bourns' ECL Terminator Application Note.

800 Series - RC Networks ECL Terminator Circuits

General Description

Digital systems incorporating Emitter Coupled Logic (ECL) or other ultra-high switching speed logic families will require signal termination to prevent transmission line effects such as reflections and ringing due to fast transition times.

Bourns 800 series resistor capacitor networks are ideal for termination of high speed transmission lines. Each network is composed of resistors for parallel termination and bypass capacitor(s) for cross talk noise reduction.

The 5 conformal coated SIP circuit variations offered are as follows.

Electrical Characteristics

Resistance Tolerance $\pm 5\%$
 Resistance Power..... 0.1 watt
 Capacitance Tolerance..... $\pm 20\%$
 Capacitor Dielectric Type X7R
 Capacitance Voltage Rating 50 Volts

Physical Characteristics

Flammability Conforms to UL 94V-0
 Leadframe Copper (Olin 194)
 Body Material Epoxy/Anhydride (Conformal Material)
 Custom Resistance Range 10 ohms to 50K ohms
 Custom Capacitance Range 39 pF to 100,000 pF

NPO and Z5U dielectrics available on a custom basis.

For Standard Values Used in Capacitors, Inductors, and Resistors, [click here](#).

Product Dimensions

MEDIUM PROFILE

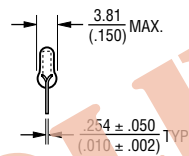
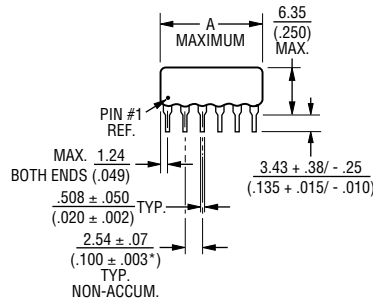

HIGH PROFILE

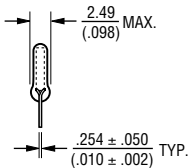
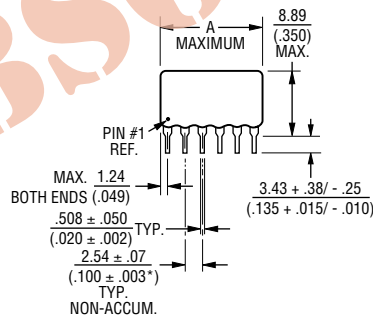

Governing dimensions are metric. Dimensions in parentheses are inches and are approximate.

*Terminal centerline to centerline measurements made at point of emergence of the lead from the body.

Typical Part Marking

801 AND 802

Represents total content. Layout may vary.

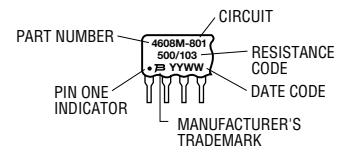

803 AND 805

Represents total content. Layout may vary.

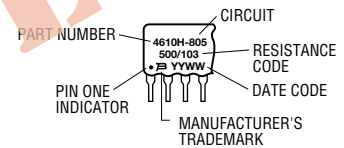

804

Represents total content. Layout may vary.

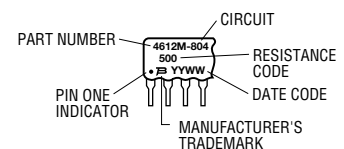

Features

- Minimizes space and routing problems, and reduces manufacturing cost per installed resistive function
- Increases board yields and reliability by reducing component count

800 Series - RC Networks ECL Terminator Circuits

BOURNS®

801 8, 10 and 12 Pin SIP

(4608M-801-RC/CCL)

Designed to terminate 6 to 10 transmission lines using parallel termination techniques. Standard resistance values include 50, 68, 75, 82, 90 or 100 ohms and are chosen to match the characteristic impedance (Z_0) of the transmission line. A 0.01 μF capacitor is provided to help maintain a solid power supply level within the network package, mitigating any cross talk or feedthrough effects. Values for R and C not shown in the following table are available on a custom basis.

Standard 801 Part Numbers

R $\pm 2\%$	C $\pm 20\%$	Bourns Part Number
50 Ω	0.01 μF	4608M-801-500/103L
68 Ω	0.01 μF	4608M-801-680/103L
75 Ω	0.01 μF	4608M-801-750/103L
82 Ω	0.01 μF	4608M-801-820/103L
90 Ω	0.01 μF	4608M-801-900/103L
100 Ω	0.01 μF	4608M-801-101/103L

801 Electrical Schematic and Application

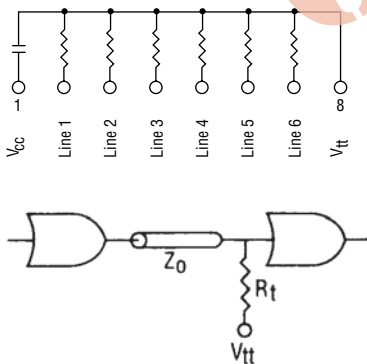

802 10 Pin SIP

(4610M-802-RC/CCL)

Designed to terminate 6 transmission lines using parallel termination techniques. Popular resistance values include 50, 68, 75, 82, 90 or 100 ohms and are chosen to match the characteristic impedance (Z_0) of the transmission line. Two 0.01 μF capacitors are provided to reduce cross talk between lines and to decrease network package inductance. Values for R and C not shown in the following table are available on a custom basis.

Standard 802 Part Numbers

R $\pm 2\%$	C $\pm 20\%$	Bourns Part Number
50 Ω	0.01 μF	4610M-802-500/103L
68 Ω	0.01 μF	4610M-802-680/103L
75 Ω	0.01 μF	4610M-802-750/103L
82 Ω	0.01 μF	4610M-802-820/103L
90 Ω	0.01 μF	4610M-802-900/103L
100 Ω	0.01 μF	4610M-802-101/103L

802 Electrical Schematic and Application

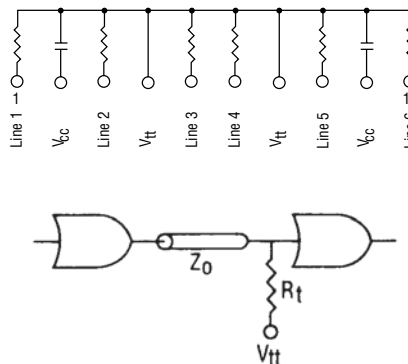

803 8, 10 and 12 Pin SIP 10K ECL

(4610H-803-ZoC/CCL)

Designed to terminate 6 to 10 transmission lines using Thevenin equivalent parallel termination techniques in systems using 10K ECL. Popular impedance values include 50, 70, 75, 80, 90, 100, 120, 150 or 200 ohms. Standard values for R1 and R2, based on Z_0 , have been chosen to accommodate 10K ECL designs. A 0.1 μF capacitor is provided to reduce cross talk noise within the network package. Values for Z_0 and C not shown in the following table are available on a custom basis. This type of termination is an alternative to parallel termination used when a separate V_{tt} power supply is not available.

Standard 803 Part Numbers

Z_0 $\pm 2\%$	R1	R2	C $\pm 20\%$	Bourns Part No.
50 Ω	81 Ω	130 Ω	0.1 μF	4610H-803-500/104L
70 Ω	113 Ω	182 Ω	0.1 μF	4610H-803-700/104L
75 Ω	121 Ω	195 Ω	0.1 μF	4610H-803-750/104L
80 Ω	130 Ω	208 Ω	0.1 μF	4610H-803-800/104L
90 Ω	146 Ω	234 Ω	0.1 μF	4610H-803-900/104L
100 Ω	162 Ω	260 Ω	0.1 μF	4610H-803-101/104L
120 Ω	194 Ω	312 Ω	0.1 μF	4610H-803-121/104L
150 Ω	243 Ω	390 Ω	0.1 μF	4610H-803-151/104L
200 Ω	325 Ω	520 Ω	0.1 μF	4610H-803-201/104L

803 Electrical Schematic and Application

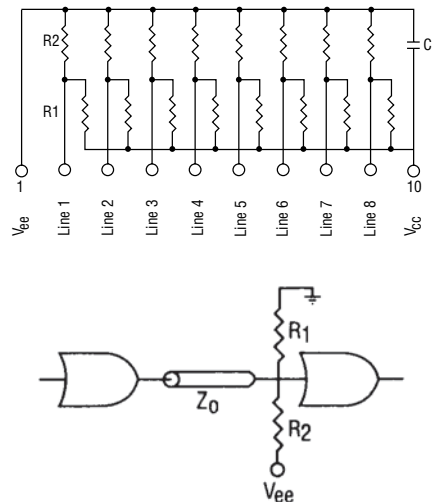

800 Series - RC Networks ECL Terminator Circuits

BOURNS®

804 12 Pin SIP ECL

(4612M-804-RCL)

Designed to terminate 6 transmission lines using parallel termination techniques. Popular resistance values include 50 or 100 ohms. A 0.1 μF capacitor is provided for connection to V_{ee} . Two 0.01 μF capacitors are provided for connection to V_{tt} . Values for R and C not shown in the following table are available on a custom basis.

Standard 804 Part Numbers

R $\pm 2\%$	Ct $\pm 20\%$	Ce $\pm 20\%$	Bourns Part Number
50 Ω	0.01 μF	0.1 μF	4612M-804-500L
100 Ω	0.01 μF	0.1 μF	4612M-804-101L

804 Electrical Schematic and Application

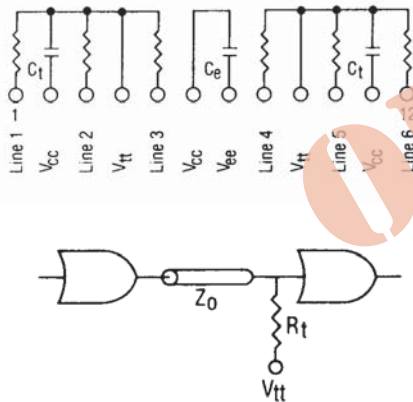

805 8, 10 and 12 Pin SIP 100K ECL

(4610H-805-ZoC/CCL)

Designed to terminate 6 to 10 transmission lines using Thevenin equivalent parallel termination techniques in systems using 100K ECL. Popular impedance values include 50, 70, 75, 80, 90, 100, 120, 150 or 200 ohms. Standard values for R1 and R2, based on Z_0 , have been chosen to accommodate 100K ECL designs. A 0.1 μF capacitor is provided to reduce cross talk noise within the network package. Values for Z_0 and C not shown in the following table are available on a custom basis. This type of termination is an alternative to parallel termination used when a separate V_{tt} power supply is not available.

Standard 805 Part Numbers

Z_0 $\pm 2\%$	R1	R2	C $\pm 20\%$	Bourns Part No.
50 Ω	90 Ω	113 Ω	0.1 μF	4610H-805-500/104L
70 Ω	126 Ω	158 Ω	0.1 μF	4610H-805-700/104L
75 Ω	135 Ω	169 Ω	0.1 μF	4610H-805-750/104L
80 Ω	144 Ω	180 Ω	0.1 μF	4610H-805-800/104L
90 Ω	161 Ω	202 Ω	0.1 μF	4610H-805-900/104L
100 Ω	180 Ω	225 Ω	0.1 μF	4610H-805-101/104L
120 Ω	216 Ω	270 Ω	0.1 μF	4610H-805-121/104L
150 Ω	270 Ω	338 Ω	0.1 μF	4610H-805-151/104L
200 Ω	360 Ω	450 Ω	0.1 μF	4610H-805-201/104L

805 Electrical Schematic and Application

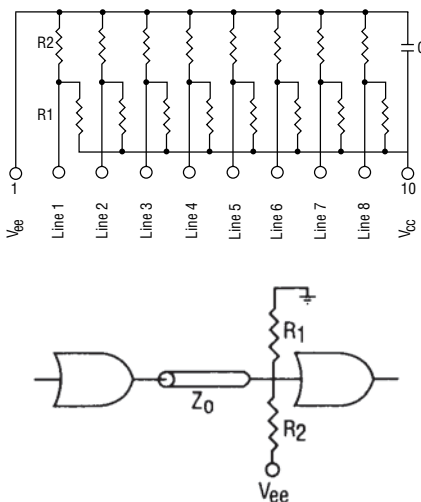

How To Order 801

46 08 M - 801 - 500 103 L

Model _____
(46 = Conformal SIP)
Number of Pins _____
(8, 10, 12)
Physical Config. _____
• M = Medium Profile
Electrical Configuration _____
Resistance Code _____
• First 2 digits are significant
• Third digit represents the number of zeros to follow.
• Units = ohms
Capacitance Code _____
• First 2 digits are significant
• Third digit represents the number of zeros to follow.
• Units = picofarads
Termination _____
L = Lead Free (Sn/Ag/Cu-plated)
Consult factory for other available options.

How To Order 803 and 805

46 08 H - 803 - 101 103 L

Model _____
(46 = Conformal SIP)
Number of Pins _____
(8, 10, 12)
Physical Config. _____
• H = High Profile
Electrical Configuration _____
• 803 • 805
Impedance Code _____
• First 2 digits are significant
• Third digit represents the number of zeros to follow.
• Units = ohms
Capacitance Code _____
• First 2 digits are significant
• Third digit represents the number of zeros to follow.
• Units = picofarads
Termination _____
L = Lead Free (Sn/Ag/Cu-plated)
Consult factory for other available options.

How To Order 804

46 12 M - 804 - 500 L

Model _____
(46 = Conformal SIP)
Number of Pins _____
Physical Config. _____
• M = Medium Profile
Electrical Configuration _____
Resistance Code _____
• First 2 digits are significant
• Third digit represents the number of zeros to follow.
• Units = ohms
Termination _____
L = Lead Free (Sn/Ag/Cu-plated)
Consult factory for other available options.

REV. 04/10

Specifications are subject to change without notice.
Customers should verify actual device performance in their specific applications.