

Features

- DC to 4 GHz
- Flanged model
- Low VSWR



This series is obsolete and not recommended for new designs.

Applications

- High power RF transmission

CHF5225CBF Series 60 W Power RF Flanged Chip Termination

General Specifications

SubstrateBeo
 Resistive FilmThick Film
 TabAg
 Cover Substrate AL203
 Mounting Flange Cu plated with Ni
 Resistance50 W
 Tolerance±5 %
 Packaging 100 pcs./box

Absolute Ratings

Power60 W
 Frequency4.0 GHz
 VSWR 1.2 Maximum

Characteristic Curve

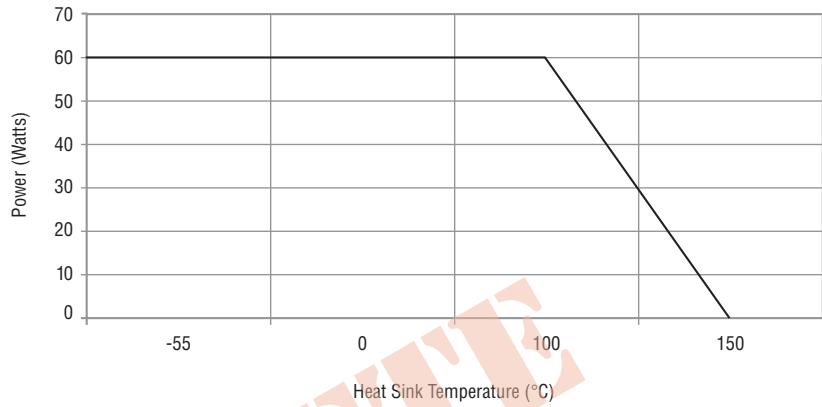

Product Dimensions

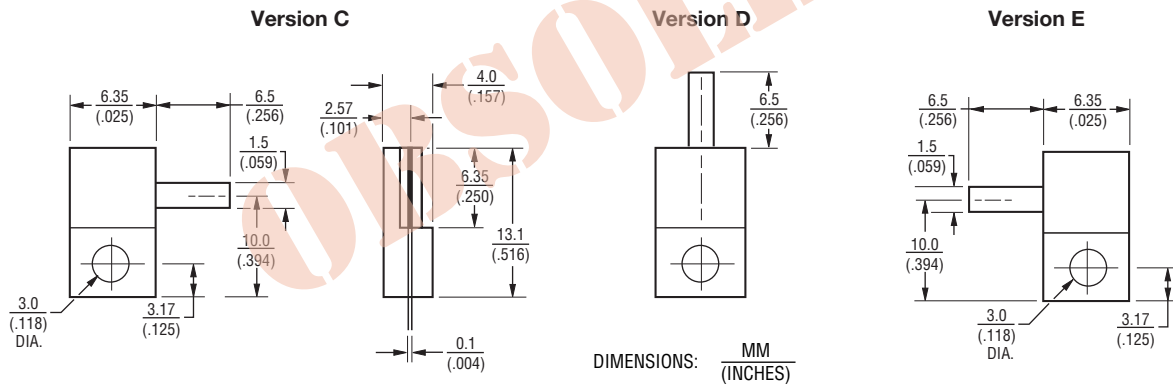

How To Order

CHF 5225 C B F 500 L

Model _____

Size _____

Version _____

Substrate _____

Mount _____
 F = Flange

Value _____
 500 = 50 Ohm

Function _____
 L = Termination

REV. 12/15

*RoHS Directive 2002/95/EC Jan. 27, 2003 including annex and RoHS Recast 2011/65/EU June 8, 2011.

Specifications are subject to change without notice.

The device characteristics and parameters in this data sheet can and do vary in different applications and actual device performance may vary over time. Users should verify actual device performance in their specific applications.