

Vectored VDSL2

Protection for Class AB Driver with Active Termination

Bourns® PortNote® solutions provide protection recommendations for typical port threats.

Solution Products



TCS-DL004-250-WH



CD143A-SR12



2036-42-SM-RPLF



2018-35-SMC-RPLF

Objective

VDSL2 uses frequencies of up to 30 MHz to provide data rates exceeding 100 Mbit/s simultaneously in both upstream and downstream directions. This solution protects these ports against lightning surge and AC power contact threats.

Solution

- 1 TCS™ High-Speed Protector: TCS-DL004-250-WH
- 1 TVS Diode Array: CD143A-SR12
- 1 Gas Discharge Tube (GDT): 2036-42-SM-RPLF or
- 2 GDT with FLAT™ Technology: 2018-35-SMC-RPLF

Compliance

- ITU-T K.20, K.21 (2016) Basic
- ITU-T K.20, K.21 (2016) Enhanced

Alternate Recommendations

Other PortNote® Solutions:

- VDSL Line Side Protection - ITU-T Solution
- VDSL: Line Side Protection
- VDSL: Driver Side Protection

Variations of this circuit are available depending on specific design constraints; contact your local Bourns technical representative for more information.

Benefit

This solution provides protection on the driver side without impairing the VDSL2 signal.

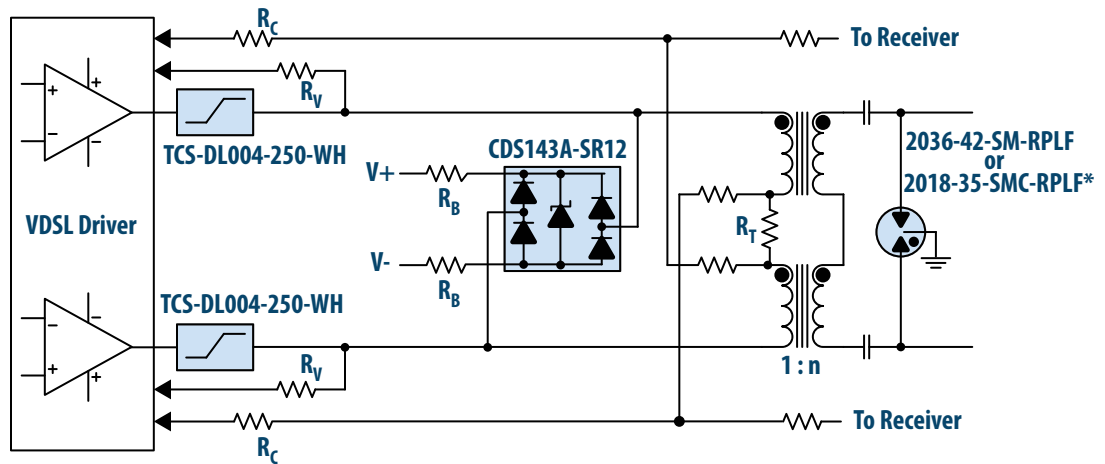

The schematic above illustrates the application protection and does not constitute the complete circuit design. Customers should verify actual device performance in their specific applications.

* For low-profile applications, use GDT with FLAT™ Technology: 2015-35-SMC-RPLF.

Request Sample

To order samples, click on the "Request Sample" button.

www.bourns.com

BOURNS[®]

Americas: Tel +1-951 781-5500
Email americus@bourns.com

EMEA: Tel +36 88 520 390
Email eurocus@bourns.com

Asia-Pacific: Tel +886-2 256 241 17
Email asiacus@bourns.com