

Product Change Notification

PRECISION POTENTIOMETERS



May 24, 2012

Bourns® Sensors & Controls Product Line Introduces Model 6639 Product Enhancements

In line with our commitment to product excellence and continuous improvement, Bourns® Sensors & Controls Product Line is pleased to introduce design enhancements to our [Model 6639 Single-Turn Precision Potentiometer](#).

The design enhancements include the addition of a C-ring to help prevent damage that may be induced by excessive axial force applied to the shaft when installing gears or other mechanical devices, and the addition of an internal shoulder to the shaft to better resist shaft pull out from the body if excessive shaft pull force is applied.

Please refer to the shaft/bushing design illustrations below:

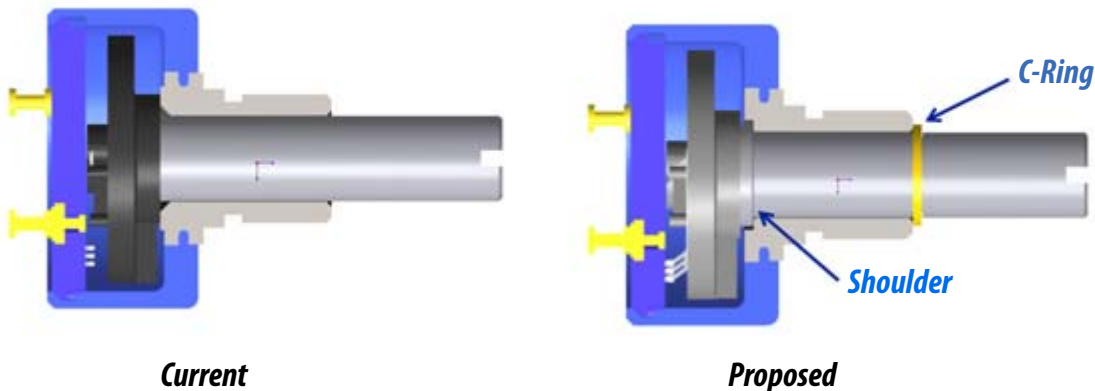

Externally, the design enhancements will be recognized by the C-ring that is visible in front of the bushing. The noted enhancements to this product family will have no effect on form, fit or function. All performance specifications listed on the current data sheet will remain unchanged. These design enhancements allow the potentiometer to withstand higher axial loads typically encountered on installation or removal of mechanical devices from the shaft.

Please note that enhancements to this product family will be implemented in production and begin shipping on July 1, 2012. Please ensure that your customers are notified of these scheduled product enhancements and implementation date.

Should you have any questions or need additional information, please contact [Customer Service/Inside Sales](#).