

APPLICATION BRIEF

Situation

- Robotics has advanced significantly in recent years. Improvements in component power density let these systems execute more precise movements and mimic human motion.
- Higher precision and higher duty cycles require more accurate and durable drive components.
- Brushless DC (BLDC) motors run at higher efficiency with longer life and tighter control than brushed or stepper motors. Robotic designs favor BLDC motors for these reasons.
- BLDC motors present large inductive loads and draw high peak currents, so the surrounding circuitry must handle both.
- Higher power and tighter control require components that discharge stored energy, limit transients, and measure current accurately.
- Thick film power resistors, wirewound resistors, and shunts handle these functions.
- This brief shows where Bourns® components fit in a BLDC drive for robotics and which parts to specify.

Solution

This brief features the Bourns® PF2472 and PWR263 Thick Film Power Resistors; the S, UT, UB, UAL, UWP, and BR Wirewound Resistors; and the CSS2H-2512 and CRE2512 Current Sense Resistors

These parts offer high power ratings in multiple package sizes, giving designers compact options for discharge, snubber/bleeder, and current sense functions.

Discharge—PWR and PF thick film resistors

- The PWR and PF Series discharge stored energy on the 48 VDC link and at the motor.
- BLDC motors with large inductive loads store significant energy during operation. Without a discharge path, that energy builds as heat across the transistors and motor windings, stressing components and shortening life.
- PWR and PF resistors dissipate energy and limit current, protecting the motor and the drive transistors.

Current sensing—CSS and CRE shunt resistors

- The CSS and CRE Series measure the voltage drop across the sense element, which the control circuit converts to a current reading.
- Phase-current feedback lets the controller respond to load changes and limit current to the motor when it exceeds safe limits.
- Accurate shunts keep motor control consistent and protect the drive from high-energy transients.

Snubber and bleeder—wirewound resistors

- The S, UT, UB, UAL, UWP, and BR series dissipate pulse energy and bleed stored charge in snubber and bleeder circuits.
- Robotic drives require controlled discharge of the DC link and bulk capacitors after power-down to protect technicians and downstream electronics.
- High surge and pulse ratings, combined with stable resistance under repeated pulses, keep the system behaving predictably over life.

PF series characteristics

- Resistance range: 0.1 Ω to 20 k Ω
- Power rating: up to 100 W with heatsink
- Operating temperature: -55°C to $+175^{\circ}\text{C}$
- Thermal resistance: 1.3 $^{\circ}\text{C}/\text{W}$

PWR series characteristics

- Resistance range: 0.02 Ω to 130 k Ω
- Power options: 20 W and 35 W
- TCR: ± 100 ppm/ $^{\circ}\text{C}$
- Electrically isolated backplate
- AEC-Q200 compliant

CSS series characteristics

- Resistance: 0.2 m Ω to 5.0 m Ω
- Available sizes: 2512, 3920, 5930, 4026
- Power rating: up to 15 W
- EB-welded metal strip
- AEC-Q200 compliant; TCR ± 50 ppm/ $^{\circ}\text{C}$; operating range -55°C to $+170^{\circ}\text{C}$; low thermal EMF

CRE series characteristics

- Resistance: 1 m Ω to 9 m Ω
- Power options: 2 W and 3 W
- Inductance below 5 nH
- AEC-Q200 compliant; TCR ± 50 ppm/ $^{\circ}\text{C}$; operating range -55°C to $+170^{\circ}\text{C}$; low thermal EMF

Wirewound series characteristics (S, UT, UB, UAL, UWP, BR)

- Resistance: 1 m Ω to 320 k Ω
- Power rating: up to 50 W
- Tolerances: 0.05 % to 10 %
- TCR: ± 20 to ± 200 PPM/ $^{\circ}\text{C}$
- Operating temperature: -55°C to $+350^{\circ}\text{C}$
- Through-hole and surface mount packages; low-inductance options available

APPLICATION BRIEF

Solution (Continued)

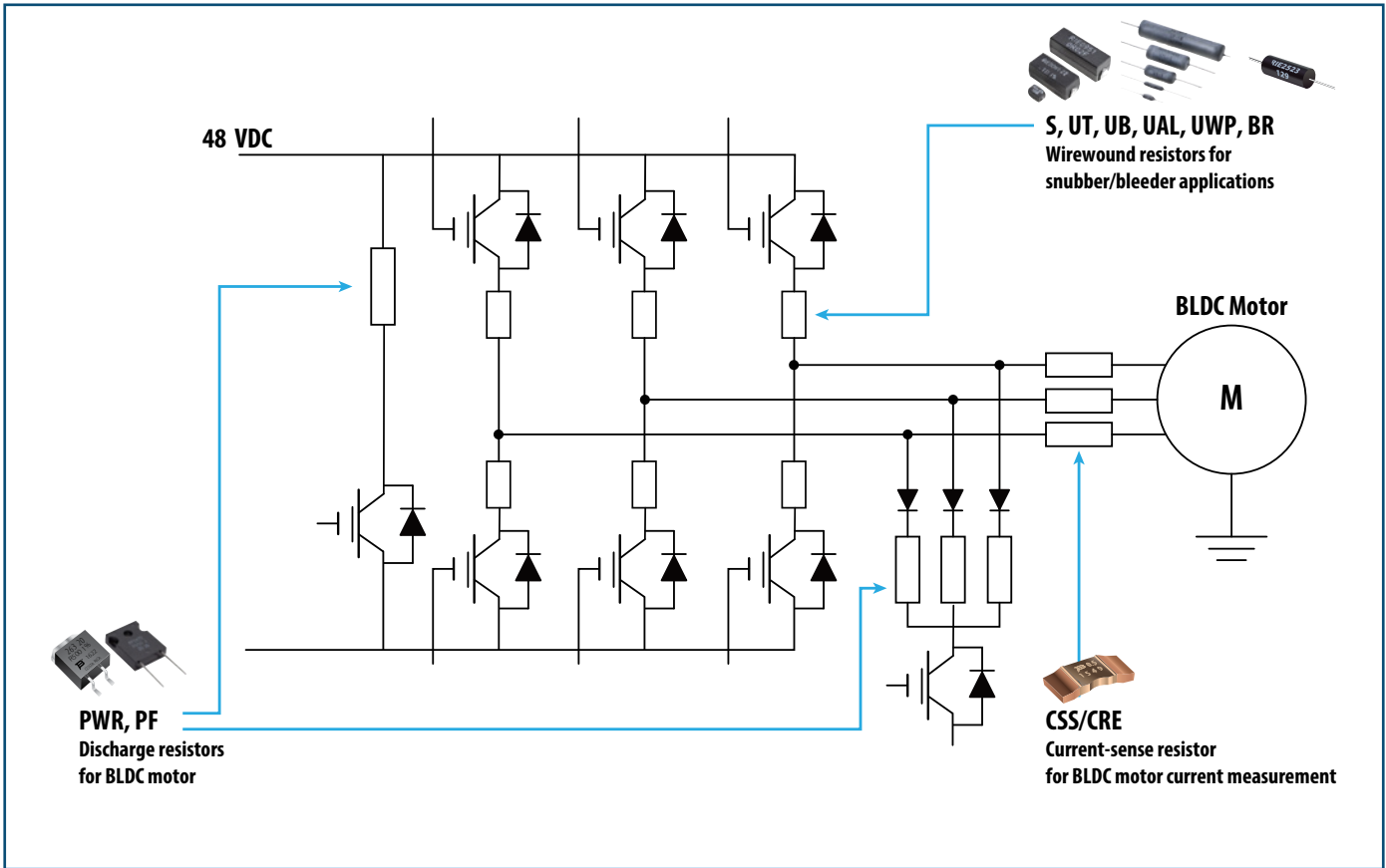

Figure 1 | BLDC drive schematic showing where Bourns® components fit

Benefits

- **Board space:** Small footprints and high-power density reduce the board area needed for discharge and current sensing.
- **Thermal headroom:** Low thermal resistance (1.3 °C/W on PF) and operating ranges up to +350 °C on wirewound parts keep components within spec under sustained load.
- **Measurement accuracy:** Low shunt resistance, ±50 ppm/°C TCR on CSS and CRE, and low thermal EMF keep current readings consistent across temperature and load.
- **Pulse and surge handling:** Wirewound parts absorb repeated pulses in snubber and bleeder circuits without resistance drift, keeping overshoot and residual energy under control.
- **Portfolio breadth:** Bourns covers discharge, current sensing, and snubber/bleeder across the BLDC drive, with AEC-Q200-compliant options for automotive and high-reliability programs.

Learn More

- [Bourns® Power Resistors](#)
- [Bourns® Current Sense Resistors](#)
- [Bourns® Wirewound Resistors](#)