

A Simple, High-Speed All-in-One Solution for RS-485 Protection

WHITE PAPER



TBU® High-Speed Protectors (HSPs)



Gas Discharge Tube (GDT) Surge Arrestors



TISP® Thyristor Surge Protectors

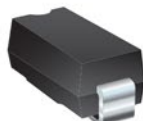

TVS Diodes

INTRODUCTION

Advancements in automation technologies are transforming a diverse range of industrial and consumer/home applications, fueling the expansion of edge computing, data analytics and the Internet of Things (IoT). The requirement to support data or sensor information collection is driving next-generation designs to help maximize business productivity. In many industrial settings, the RS-485 interface is the most popular interface used for this function.

Whether in new or legacy RS-485-based applications, it is still important to include circuit protection in the design. Historically, it has been a challenge to incorporate a protection solution that meets application demands while providing reliable operation in remote environmental conditions. The availability of advanced protection technology now makes this possible, allowing developers to remain focused on their system design.

A new family of Bourns® TBU® High-Speed Protectors (HSPs) offers the ability to block faults of hundreds of amperes and thousands of volts as primary RS-485 interface protection - the Bourns® Model TBU-DF. Designed as a complete, simple-to-use HSP, this series can be used on a multitude of data and sense lines.

This paper will present a brief background of RS-485 and highlight some of the faults that threaten RS-485 systems. It will outline the protection solutions that have been typically used to protect against these faults, and what benefits and performance characteristics make the Bourns® latest TBU® HSPs different.

A Simple, High-Speed All-in-One Solution for RS-485 Protection



TBU® High-Speed Protectors (HSPs)



Gas Discharge Tube (GDT) Surge Arrestors



TISP® Thyristor Surge Protectors

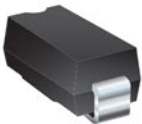

TVS Diodes

WHY RS-485 PROTOCOL IS SO POPULAR

When looking for a reliable network that can withstand harsh industrial environments or unregulated home environments equally well, RS-485 has a lot to offer. Its high-speed, long cable lengths, and flexible node count are among the benefits that complement its ability to withstand threats. Electrically, it can operate at half-duplex or full-duplex mode, the latter of which provides full speed, bidirectional communication. The electrical characteristics of RS-485 are summarized in Table 1.

Table 1: RS-485 Interface Specifications

Differential	Yes
Speed	32 Mbps
Sensitivity	± 100 mV
Cable length	1200 Meters
Input impedance, min.	12 ohms
Output voltage, max.	-7/+12 V
Output voltage with load, min.	± 1.5 V
Number of drivers/receivers, max.	32 each
Network topology	Multipoint
Modes of operation	Half-duplex, full-duplex

In addition, RS-485 networks are robust in nature, due in part to differential signaling. Another factor is the interface's high output voltage, which combats voltage drop over long cable runs between nodes. A compliant RS-485 port must meet IEC 61000-4-2 (ESD), IEC 61000-4-4 (EFT) and IEC 61000-4-5 (Surge) standards.

Some of the most appealing aspects of RS-485 also make the interface more susceptible to threats. Similar to what is required for the majority of wired communication systems, threats such as system transients, lightning and other types of environmental threats must be considered during the design phase. These considerations include lightning surges of 5 kV and 1 kA, power induction modeled as 600 Vrms for up to one second, longer duration moderate current power cross, and earth potential rise.

Furthermore, electrostatic discharge (ESD) that can occur from handling during installation has the potential to damage or destroy electronics. Human error is also a factor as it is not uncommon to encounter miswiring and short circuit faults. For example, a DC bus may be present for relay control and actuators, which means a wiring error could result in a DC power connection to RS-485 differential signal lines. In a multipoint network, differing ground potentials can cause problems. RS-485 can tolerate up to ± 7 volts of differential ground potential between nodes. With the flexibility to add and remove nodes over long cable distances while the network is operating, protection against all these threats is obtained.

A Simple, High-Speed All-in-One Solution for RS-485 Protection



TBU® High-Speed Protectors (HSPs)



Gas Discharge Tube (GDT) Surge Arrestors



TISP® Thyristor Surge Protectors

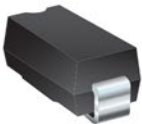

TVS Diodes

RS-485 PROTECTION CONSIDERATIONS

The installed base of RS-485 systems is massive, and there are numerous circuit protection solutions available various types and levels of protection. Overvoltage circuit protection comes in two types – clamping the voltage to a tolerable upper limit and dissipating the energy or diverting the energy to ground through a low impedance shunt. The most common way to address protection in RS-485 interfaces is to use a shunting solution for primary protection. However, in highly exposed applications the shunting device may not be sufficient on its own. Electronic equipment can be damaged by voltages in the tens of volts and currents in the hundreds of milliamperes if they are experienced for more than microseconds. A shunt protector that is fast enough to limit the voltage and rated to handle the surge current may be physically too large, not economically viable, or have a capacitance that is too high, causing destruction of the RS-485 signal.

The viable protection solution must also be able to short circuit and protect the interface from a surge that may peak on the order of 1000 A. This is quite a difficult task, especially considering that the surge can develop in mere microseconds. Thus, designers often have to ensure that multiple stages of circuit protection are used and coordinated (shown in Figure 1). This protection example uses fuses, resistors, thyristors, and diodes to make up the secondary protection. A GDT is often chosen for its current handling capability, followed by a semiconductor thyristor for speed.

Selecting the right combination of components isn't necessarily a simple task, and making the wrong choice can cause field failures, increase maintenance costs, and affect overall reliability.

Multiple overvoltage and overcurrent protection components have interactions that require considerable time and attention from the designer to ensure that the final solution meets system specifications. The impedances and behaviors of all these devices must be understood and coordinated. This requires detailed knowledge of surge threat protection including performance of all protective components' shunting, blocking, and coordinating (voltage/current/power/energy/time) characteristics in addition to the conditions under which they trigger. It is also vital to understand the interface's ability to resist voltages and currents (voltage/current/time), its transmission system specifications (bandwidth, maximal allowable loss), and the interaction between multi-stage protection circuits.

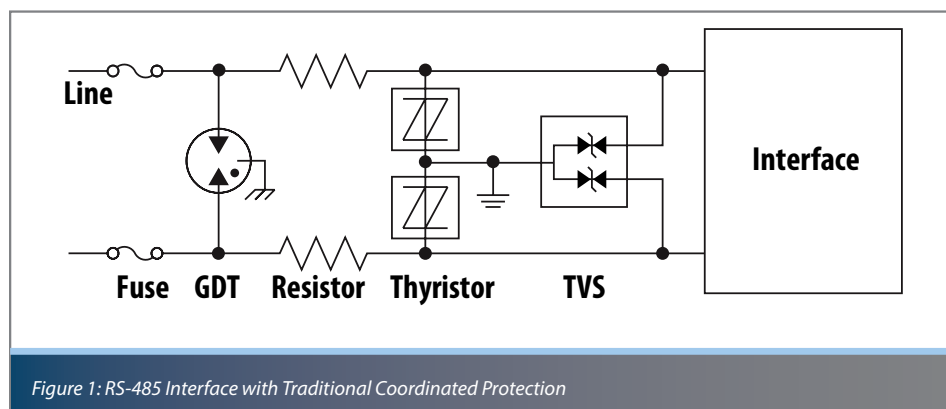

Figure 1: RS-485 Interface with Traditional Coordinated Protection

A Simple, High-Speed All-in-One Solution for RS-485 Protection



TBU® High-Speed Protectors (HSPs)



Gas Discharge Tube (GDT) Surge Arrestors



TISP® Thyristor Surge Protectors

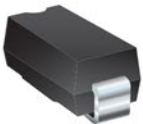

TVS Diodes

USING THE BOURNS® TBU® HSP

Bourns designed its latest Transient Blocking Unit High-Speed Protector (TBU® HSP) as an integral protection solution for RS-485 communication components. The device functions to block excessive communication line current and prevent damage to line transceivers and other interface components. The TBU® HSP works by detecting excess current and producing a high series impedance in the communication line to block the current flow.

WHAT MAKES BOURNS® HSPs DIFFERENT

Offering a proven protection solution, Bourns® TBU® HSPs have been successfully integrated into a variety of applications for over a decade. The Bourns® TBU® HSP is a simple device, based on a MOSFET switch, that is placed between the line and the protected load. During normal operation, the Bourns® TBU® HSP presents a low, finite, series resistance to the line. As transient current increases to the HSP trigger current level, the HSP switches to a very high impedance or protected state. This limits the current to the leakage current value, effectively disconnecting the transient from the sensitive RS-485 transceiver. Regardless of the incident's transient signal characteristics, this transition to the protected state occurs in less than 1 microsecond with flat response over operating temperature. The Bourns® TBU® HSP will reset once the voltage across it drops below V_{reset} .

With a lightning surge or other voltage surge event at Time 1 (see Figure 2), voltage and current will rise until the current-limiting portion of the circuit limits current to the level of I_{out} (Time 2). At this point, the voltage disconnect portion of the circuit operates and by Time 3 (>1 microsecond), the load is disconnected from the surge. During the remainder of the surge (Time 4), the TBU® HSP remains in the protected state of very low current and voltage at the load.

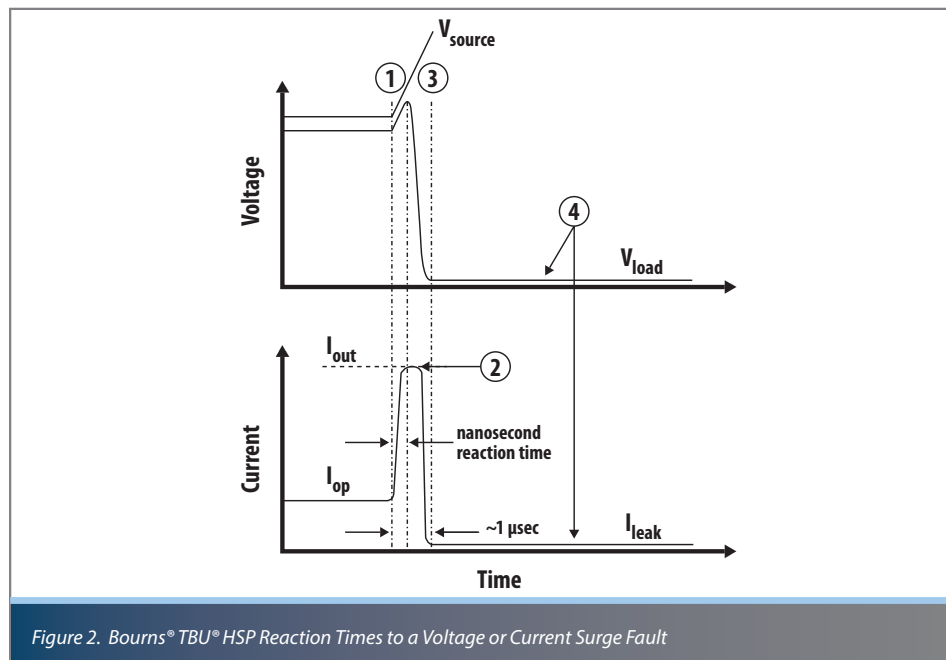

A Simple, High-Speed All-in-One Solution for RS-485 Protection



TBU® High-Speed Protectors (HSPs)



Gas Discharge Tube (GDT) Surge Arrestors



TISP® Thyristor Surge Protectors

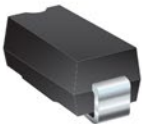

TVS Diodes

WHAT MAKES BOURNS® HSPS DIFFERENT (CONTINUED)

Each TBU® HSP is specified with a maximum voltage for safe operation. If the surge voltage is expected to exceed this, then an overvoltage protector (OVP) such as a metal oxide varistor (MOV), TISP® Thyristor Surge Protector, GDT, or GMOV™ Hybrid Overvoltage Protection Component can be connected from line to ground to limit the voltage across the HSP. In applications with sensitive data bandwidth, a GDT or GMOV™ device is typically recommended for overvoltage protection. The configuration with overvoltage protection is shown in Figure 3.

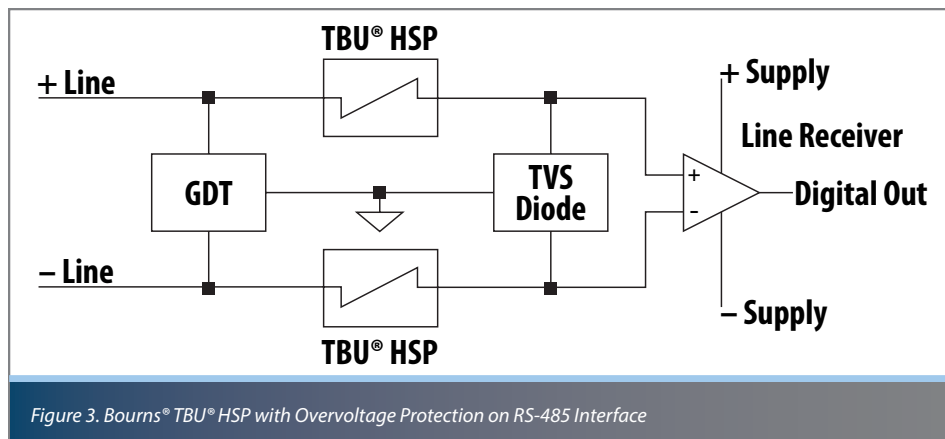

Figure 3. Bourns® TBU® HSP with Overvoltage Protection on RS-485 Interface

In this design, the TBU® HSP detects excessive current and blocks it from reaching the protected load downstream. As the voltage on the line continues to increase, the GDT then protects the TBU® HSP from excessive voltage. In turn, the TVS Diode suppresses very fast ESD and EFT.

A Simple, High-Speed All-in-One Solution for RS-485 Protection

A DUAL-CHANNEL BIDIRECTIONAL SOLUTION

Committed to continually addressing the unique circuit protection needs of various applications, Bourns designed its latest Model TBU-DF TBU® HSP as a single TBU® HSP device for RS-485 protection, that takes care of induced lightning surges, due to ESD, installation errors, cabling faults and associated issues. What makes the Model TBU-DF particularly useful in RS-485 applications is its ability to offer dual-channel bidirectional protection matching the interface's differential, bidirectional qualities. That means a single Model TBU-DF device can be used for each differential signal pair, with one channel connected to the positive signal and the other to the negative signal. This makes it easier to place and route the application circuit board, reduces component count, and ensures consistent operation, balance, and performance for a differential signal pair, as seen in Figure 4 below.



TBU® High-Speed Protectors (HSPs)



Gas Discharge Tube (GDT) Surge Arrestors



TISP® Thyristor Surge Protectors

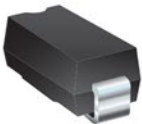

TVS Diodes

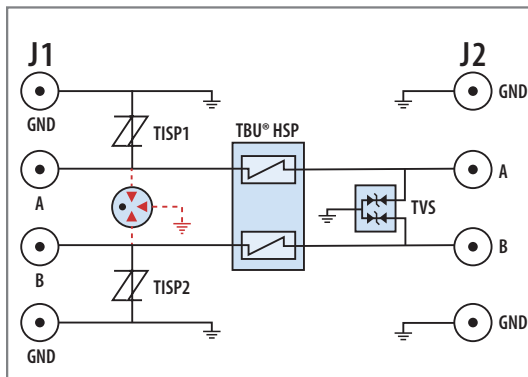

Figure 4 – Bourns® EvalBoard4 RS-485 Evaluation Board Schematic

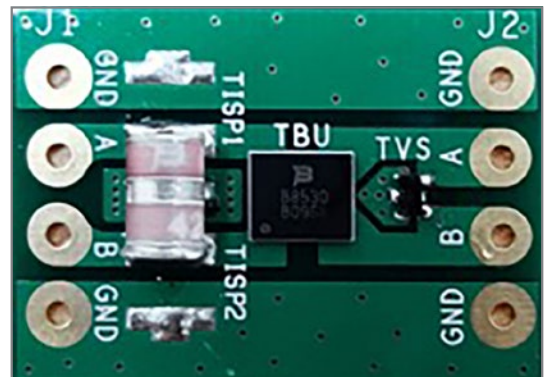

Figure 5 – Bourns® EvalBoard4 RS-485 Evaluation Board Top Side Layout

With so many variables to account for when coordinating multi-stage solutions, the designer can focus their time on design, knowing circuit protection is handled with the Bourns® TBU® HSP. Specified circuit protection performance is reliable regardless of cable length, data rate, number of nodes, and other devices present on the RS-485 network. Plus, the dual-channel Model TBU-DF does not introduce unbalanced impedance, inductance, or capacitive load to the RS-485 network.

A Simple, High-Speed All-in-One Solution for RS-485 Protection



TBU® High-Speed Protectors (HSPs)



Gas Discharge Tube (GDT) Surge Arrestors



TISP® Thyristor Surge Protectors



TVS Diodes

EVALUATION RESOURCE

Bourns offers an evaluation board ([RS-485EVALBOARD4](#)) and an accompanying application note - a valuable resource to help demonstrate the effectiveness and simplicity of this solution. There is no need to breadboard and swap component values over multiple stages until the right solution is found. The evaluation board brief will highlight options for two levels of lightning surges that use a TISP® Thyristor Surge Protector for the lower surge level and a GDT for the higher surge level. The coordinated components installed on the evaluation board were selected as an ideal solution for RS-485 protection. Measurements and tests performed with the evaluation board will resemble the performance of the deployed product (but designers should verify actual performance in their application). Similarly, the expected conditions can be simulated to help ensure that the voltage level across the TBU® HSP is within ratings.

CIRCUIT PROTECTION ADVANCEMENTS FROM BOURNS

Bourns® TBU® HSPs offer exceptional protection against common RS-485 system threats including transients due to environmental factors, from ESD as operators work on interfaces or from miswiring and installation faults that happen as the result of human error. Considering the numerous threats and performance considerations designers must contend with, Bourns has developed a cost-effective way to reliably protect RS-485 interfaces. Delivering associated overvoltage protection to ground from each line, the Bourns® Model TBU® HSP provides a solution to ensure that excess voltage can crowbar to ground up to rated limits. The simplicity of its use provides inherent coordination with peripheral circuitry and fewer variables for the designer to consider. And, by integrating the Model TBU-DF TBU® HSP with optional overvoltage protectors like Bourns® TISP®, MOV, GDT or GMOV™ devices, designers get a comprehensive protection solution that gives them accurate, sub-microsecond response benefits along with robust protection.

Bourns is committed to continued technology advancements to address protection needs in a range of applications. Serving diverse markets, Bourns has demonstrated its leadership in defining future circuit protection solutions with proven excellence in design backed by superior customer service.

www.bourns.com

BOURNS®

Americas: Tel +1-951 781-5500
Email americus@bourns.com

EMEA: Tel +36 88 885 877
Email eurocus@bourns.com

Asia-Pacific: Tel +886-2 256 241 17
Email asiacus@bourns.com

COPYRIGHT© 2019 • BOURNS, INC. • 03/19 • e/K1929

"Bourns" and "TISP" are registered trademarks of Bourns, Inc. in the U.S. and other countries.

"GMOV" is a trademark of Bourns, Inc. in the U.S. and other countries.