

Riedon™ PF2472 Series Power Resistors by Bourns

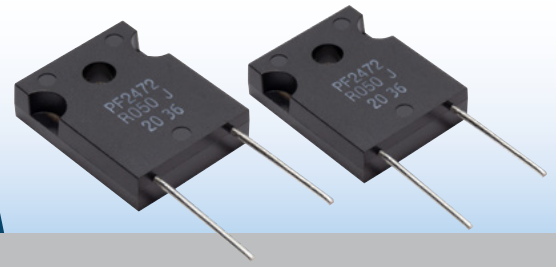

NEW PRODUCT BRIEF

INTRODUCTION

The Riedon™ PF2472 Series Power Resistors by Bourns are constructed using thick film technology with high stability film resistance elements. This series has a power rating of up to 100 W (with heat sink), a wide resistance value range from 100 milliohms (mΩ) to 20 kilohms (kΩ), an operating voltage of 700 V, and resistance tolerance options of 1 % and 5 %. This new series also offers high heat tolerance in a compact TO-247 package.

The PF2472 Series enables high power dissipation and handling while maintaining exceptional stability. Featuring low inductance (<50 nH), high-pulse handling, and high-frequency handling, these power resistors are ideal for industrial power supplies, motor drives, inverters, Battery Management Systems (BMS), and other high-performance industrial electronics. The PF2472 Series further strengthens Bourns' high-power resistor product portfolio offering in-demand advanced features for applications where high-power capabilities, reliability, and precision are needed.

FEATURES

- Typical TO-247 packaging enabling operating temperatures up to +175 °C
- Excellent pulse handling capabilities with power ratings of up to 100 W
- Resistance value ranges from 100 mΩ to 20 kΩ
- Temperature coefficients of ±200 - 300 PPM/°C
- Precision resistance tolerance options of ±1 %, ±5 %
- 700 V operating voltage
- 1.3 °C/W ensures efficient thermal dissipation
- RoHS compliant*

MARKET TRENDS

Next-generation systems continue to advance with increasing requirements for higher power density along with improved efficiency. To achieve this, systems are transitioning to higher voltages and currents, which helps reduce their costs and improve efficiency. As these systems are developed, implementing power resistors becomes even more critical in helping dissipate heat. With systems increasing in power and space being a constant constraint on boards, power density improvements are also asked of the power resistors. The Riedon™ PF2472 Series Power Resistors by Bourns® provide designers with a powerful, reliable, and compact power dissipation solution while remaining economical for next-generation power electronics.

APPLICATIONS

Optimal current limiting, current measurement, snubber circuit and capacitor discharge solution for a wide range of applications where high-power capabilities, reliability, and precision are needed in space-constrained designs:

- Industrial motor drives
- Power conversion systems
- Battery Management Systems

Note: The sinusoidal vibration tests done on this series with the IEC 60068-2-6 standard resulted in a ±0.25 % + 0.05 Ω resistance, making it ideal for motor drives.

BENEFITS

- Enhanced thermal efficiency
- Low inductance options (< 50nH)
- Isolated back plate
- Compact design with high power dissipation
- Lightweight TO-247 package design
- High stability film resistance elements

HOW TO ORDER

Model PF2472 **PF2472 - 1R J 1**
 Resistance Code 0R1
 For values <1 K Ω, "R" represents decimal point (Example: 0R1 = 0.1 Ω)
 For values 1K-10 KΩ, "K" represents decimal point (Example 1K = 1 KΩ, 1K5 = 1.5 KΩ)
 Tolerance F
 F = ±1 %
 J = ±5 %
 Internal Use _____
 1 = standard version

ELECTRICAL CHARACTERISTICS

Series	Photo	Power Rating (W)	Tolerance	Resistance Range (Ω)	Temperature Coefficient (TCR) (PPM/°C)	Temperature Range (°C)
PF2472		100	±1 %, ±5 %	0.1 – 20 k	±200 - 300	-55 to +175

For full characteristics, see data sheet

*RoHS Directive 2015/863, Mar 31, 2015 and Annex.

Riedon™ PF2472 Series Power Resistors by Bourns

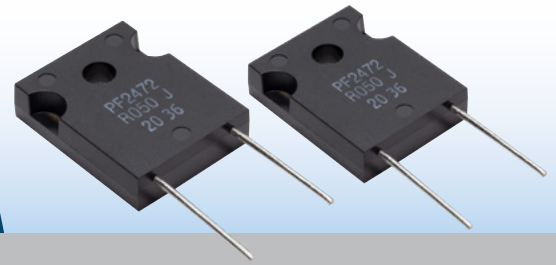

NEW PRODUCT BRIEF

PRODUCT DIMENSIONS

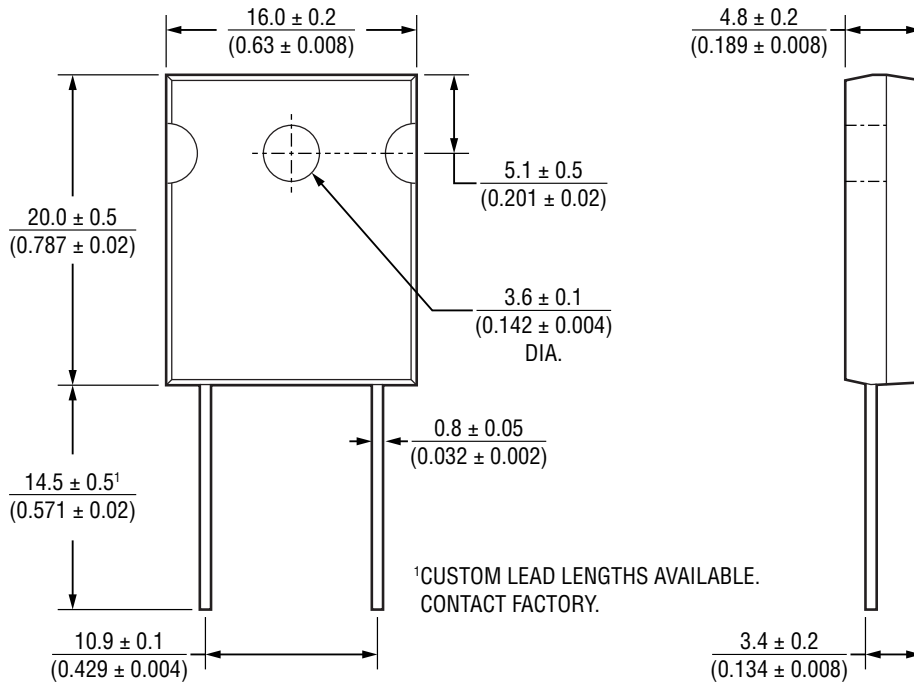

DIMENSIONS: $\frac{\text{MM}}{\text{(INCHES)}}$