

# APPLICATION NOTE

## Using Flyback Technology for Low Power Conversion Drivers

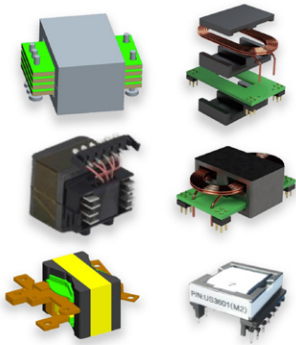

Bourns® Custom Flyback Transformers

### INTRODUCTION

On a basic level, a flyback operation for power conversion is used to change voltage and current through an isolated magnetic component. Where circuit isolation is required, flyback transformers are used in flyback converters for step-up operations. They are a cost-effective and efficient solution for an isolated power supply design in applications such as battery chargers, LED lighting systems, generators, electrical pumps, and telecom systems.

This application note explains flyback topology and provides a few Bourns solutions for low power conversion drivers. It also outlines magnetic design challenges for this type of transformer and compares it to push-pull operation in regard to isolation and safety performance.

### FLYBACK OPERATION BASICS

While the switch is turned ON, the primary of the transformer winding stores energy. During the switch's OFF time, primary stored energy is inversely moved to the secondary winding of the transformer (see Figure 1). During this time, the secondary winding discharges this stored energy to the output side of the circuit.

#### Flyback Circuit Operation

##### Flyback Jobs

- Power Conversion of Voltage/Current
- Energy Transfer
- Supply Energy while the Switch is OFF
- Energy Storage

##### Flyback "Transformer" Argument

- Is it a Classic Transformer?
- Is it a Coupled Inductor?

A bit of Both, Considering how it Operates

#### Simplified Flyback Circuit

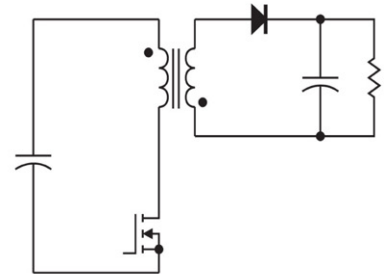
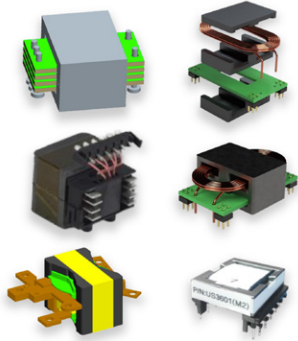

Figure 1. A simple flyback circuit operates as both an energy transfer device and an energy storage device.

The energy storage behavior of flyback operation counters the traditional transformer which, by definition, is that of energy transfer and not storage. The question then, is whether a flyback transformer is a real transformer or is it more akin to two coupled, but isolated, inductors. Another opinion is that it is a bit of both, since a flyback transformer is isolated (similar to a real transformer) but, because of its energy storage behavior, it also operates like coupled inductors.

A consideration for engineers in transformer design is to think in terms of signal integrity with respect to how the magnetics can affect the waveform (voltage in this case) as the power signal passes through it. These parasitic effects and trade-offs—such as EMC and EMI performance—are present in any effective coil design. Attention to core gapping effects used to increase current saturation effects in the core are additional considerations for signal integrity in a power conversion circuit.

## Using Flyback Technology for Low Power Conversion Drivers



Bourns® Custom Flyback Transformers

### MAINTAINING SIGNAL INTEGRITY

When considering the pulse wave anatomy of a flyback transformer circuit, an ideal output would be a well-behaved square wave. In Figure 2, note that the red line signifies real world parasitic effects contributed to the system by the transformer. The leading edge varies due to distributed capacitance, leakage inductance, and resistance. Capacitance is built up between the turns of the winding on either the primary or secondary. In a two-way device such as a flyback transformer, leakage inductance determines the amount of coupling between those two windings.

### Isolated Power Conversion Drivers – Maintaining Signal Integrity

*Signal Integrity Involves Pulse Wave Anatomy*

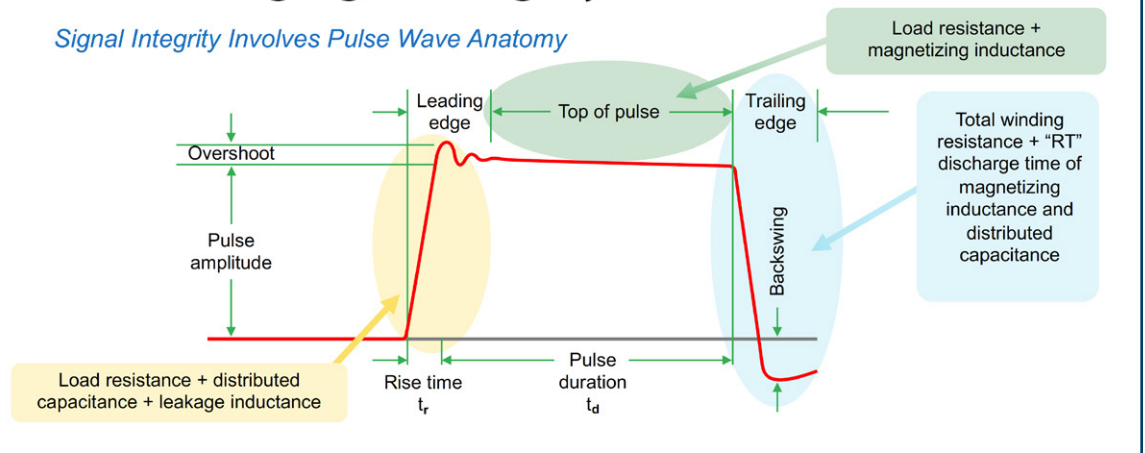
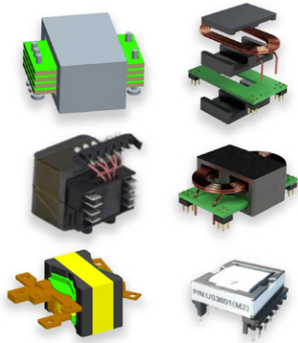

Figure 2. This illustration shows the pulse wave of a flyback transformer circuit and includes the results of the parasitics of the circuit.

The tighter the windings are placed together, the lower the leakage between windings, and the better the transit response on the top leading edge of the pulse. The top of the pulse in Figure 2 is due to load resistance at the output and the magnetizing inductance. Any minor drop before the pulse levels out is due to parasitic effects. The backswing negative overshoot indicates the total running resistance combined with the discharge time it takes for the distributed capacitance and the leakage inductance to bleed off.

## Using Flyback Technology for Low Power Conversion Drivers



Bourns® Custom Flyback Transformers

### LEAKAGE INDUCTANCE

Magnetics engineers seek to minimize the transient behavior at the leading edge of their flyback transformer design. Since leakage inductance is frequency dependent, magnetics suppliers will provide data sheet reference measurements between 10 and 100 kHz. This measurement is fine unless the application's switching mode of operation is between 200 and 500 kHz. Because leakage inductance increases when used at higher frequencies, it's always suggested that the designer contact the supplier to measure and supply a leakage inductance characteristic curve based on the operating frequency range of the application. This will provide more accurate data to the power supply design engineer.

When considering leakage inductance in conjunction with interwinding capacitance, it is important to think about the interaction between the primary and secondary windings. For example, lower leakage and better coupling can usually be achieved with closely wound windings. However, interwinding capacitance will increase too, since primary and secondary transformer windings are more tightly wound. The dichotomy is that it is best to have both low leakage inductance and interwinding capacitance. Therefore, a balance must be met based on the specific application requirements.

## Using Flyback Technology for Low Power Conversion Drivers

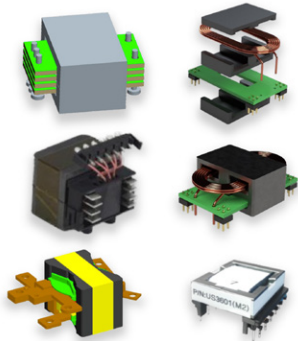

Bourns® Custom Flyback Transformers

### EXAMPLE OF HOW PARASITIC COMPONENTS AFFECT EMI

In Figure 3, notice how leakage inductance ( $L_{lk}$ ) might build up the effects of the leading edge transient response of the output wave mentioned above. Other things can further affect the circuit, such as parasitic capacitance between the drain and source legs of the FET; the distributed capacitance that can work in conjunction with primary winding leakage inductance ( $C_p$ ,  $L_{tr}$  and  $C_d$ ); and the FET output capacitance ( $C_o$ ). The combination of these three things contributes to the self-resonant frequency of the circuit as well as the distributed capacitance and leakage impact capacitance combined for the resonance frequency of the transformer.

While leakage inductance must be kept as low as possible, other factors affect the self-resonant frequency of the transformer. The goal is to keep resonance out of the region of the power supply operating frequency. This leaves room for the inner winding capacitance to flex down, which is depicted on the right-hand side of Figure 3. Note that the inner winding capacitance ( $C_{ps}$ ) affects conducted emissions and helps to determine the size of the Y-cap to be used. It is the balance between these two that should be evaluated rather than simply keeping leakage as low as possible.

### Parasitic Components Affecting EMI

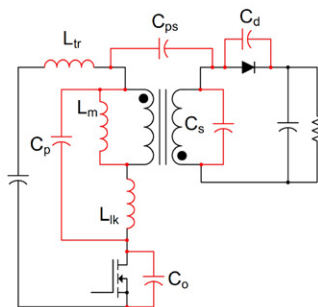

#### Sources of parasitics that cause ringing

- Leakage inductance  $L_{lk}$
- Distributed capacitance  $C_p$ ,  $C_s$ ,  $C_d$
- FET junction (output) capacitance  $C_o$

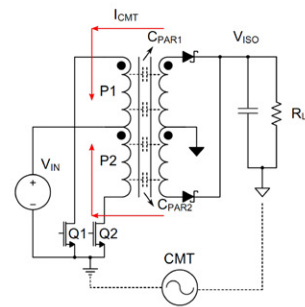

#### Source of EMI translation path

- Interwinding capacitance ( $C_{ps}$ )
- Determines Y-Cap sizing

Figure 3. These schematics indicate how parasitic components can affect EMI in your circuit.

While some designers choose to pay attention to only one requirement for their circuit design, it is suggested that an all-encompassing approach should be taken. When working with your flyback transformer supplier—where they provide only leakage inductance data—you'll want to ask for distributed capacitance and interwinding capacitance data as well. This allows for a more complete evaluation of the transformer's capabilities.

## Using Flyback Technology for Low Power Conversion Drivers

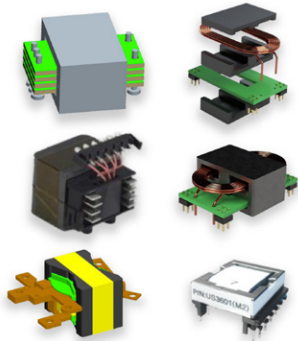

Bourns® Custom Flyback Transformers

### FLYBACK ENERGY STORAGE CONSIDERATIONS

Energy storage is another element of transformer design that affects the size of the core that can be used. For energy storage, it is important to consider the saturation current-handling ability of a given core. This typically requires an air gap in the core to lower its inductance, and thereby increase its current handling ability—at the detriment of losing magnetic permeability.

Effects of core gapping in terms of effective permeability are shown in Figure 4. Note that while field strength (green to purple in the plot) increases current handling for a given core, it also signifies a decrease of permeability, which decreases the amount of inductance per turn of wire. To maintain a given inductance per unit of current, more wire turns are necessary around the core.

### Effects of Gapping a Core

#### Core Gapping

- Increases DC current handling
  - More inductance per DC current till roll-off point (red line)
- Reduces the amount of inductance per wire turn

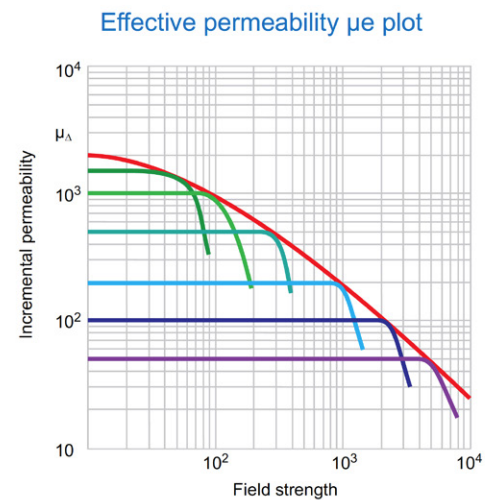
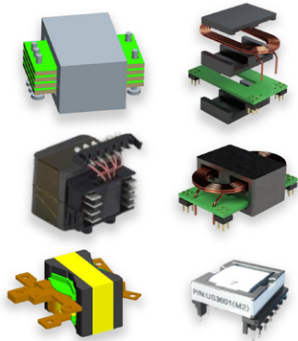

Figure 4. This illustration indicates how increases in current handling for a given core also decrease permeability.

However, this story isn't finished. Another parasitic effect of gapping is called fringing flux—the energy transfer across the gap. Since energy isn't fully translated through magnetic flux from one side of the gap to the other, it creates another leakage point that provides a center for noise or harmonic distortion. Moving the windings out of the way of this fringing flux creates undesirable space within the bobbin. Different techniques such as using layers of tape can be used to reduce the fringing effect of the center core. All these different considerations show just how complex transformer design can be. Knowing what you are trying to do and what you need from your transformer will help immensely during your design.

# APPLICATION NOTE

## Using Flyback Technology for Low Power Conversion Drivers



Bourns® Custom Flyback Transformers

### ISOLATION AND SAFETY

To discuss isolation and safety requirements that must be met within the confines of the transformer itself, we'll consider a battery management system, as an example. In this case, there must be separation between the low-voltage battery side and the high-voltage battery pack side to provide a level of galvanic isolation or protection of the user from electric shock. You will want to know the highest input voltage seen at the primary. This will help you determine the creepage and clearance needed for the design.

Clearance is defined as the distance between two objects or two parts of the transformer through air alone, while creepage is the distance between two different points along a surface, not just through air. Other considerations include the level of insulation required, if the device must operate at certain sea levels, the amount of pollution it will be exposed to such as dirt and moisture, and any other factors that may also affect the circuit.

There are multiple methods used to meet distance criteria in reference to safety. This manifests itself in the bobbin makeup, specifically in relation to the core and the windings, and can cause different looks for your transformer (see Figure 5). The top left is an example of meeting creepage and clearance distances equally between the primary and secondary side of the transformer. The bottom left shows how safety is incorporated only to one side—either primary or secondary. In lieu of physical distance, some transformers are provided with triple insulated or fully insulated wire, which separates the wire from extruded layers based on insulation requirements. Tapes can also be used to meet this same specification. Any type of sealed joint encapsulation can also be used to replace physical distance as well.

### Methods to Meet Creepage Distance

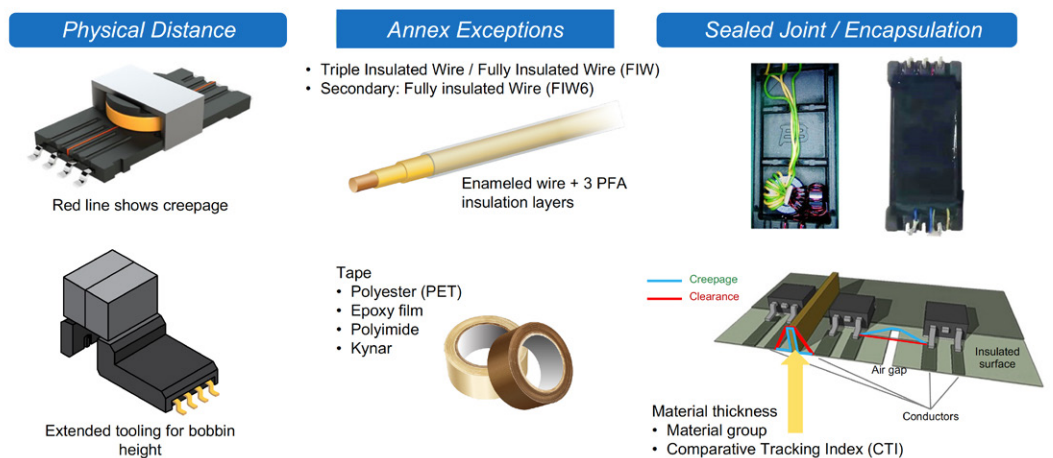
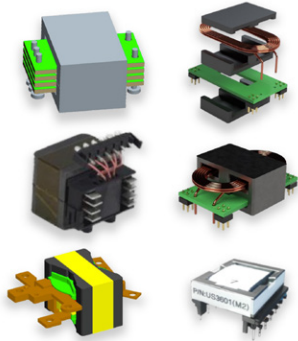

Figure 5. There are multiple ways to meet creepage distance, which will also create different looks for your transformer.

# APPLICATION NOTE

## Using Flyback Technology for Low Power Conversion Drivers



Bourns® Custom Flyback Transformers

### BOURNS FLYBACK SOLUTIONS FOR POWER CONVERSION

Bourns has a wide number of potential solutions in our catalog for low-power DC-DC applications that can be used with different chipsets from all manufacturers (see Figure 6). Many of these options are available with previously approved reference designs, making implementation quick and simple. For example, Bourns has solutions for Power over Ethernet devices as well as Internet of Things. No transformer has only one application, but the criteria and size of these options are an ideal guideline as you move forward with your design.

### Bourns® Custom Flyback Transformers - Packages to Meet Customer Needs

- **Standard Core Packages for Functional Isolation**
  - EP, EFD, RM, PQ, EE, EM, EPC
- **Bobbin and Core Tooling Capabilities**
  - Extended Rail Bobbins for High Creepage and Clearance
- **Custom Transformer Design Services**

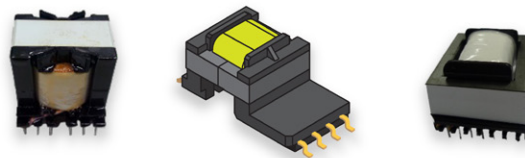
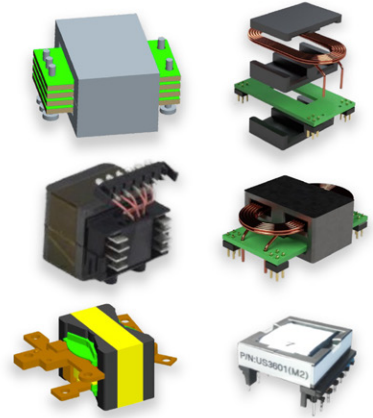

Figure 6. Bourns has a wide range of standard, off-the-shelf, and custom designs for flyback transformer designs.

The Company's configurable transformers highlight six equal windings available on one transformer body that users can wire in different configurations. This approach offers the user a variety of turns ratios, inductance levels, and current handling capabilities. If you need options to experiment with before making a final decision to move to a custom design, having this capability is ideal.

Bourns also has industry standard core packages for custom flyback transformer designs, offering the ability to provide any type of tooling needed for either core or bobbin designs to meet your requirements. Different combinations can be created using the Company's automated assembly lines or through manual processes for a high degree of quality for winding and testing, as well as advanced measurement capabilities.

[www.bourns.com](http://www.bourns.com)

**BOURNS®**

Americas: Tel +1-951-781-5500  
Email [americus@bourns.com](mailto:americus@bourns.com)

EMEA: Tel +36 88 885 877  
Email [eurocus@bourns.com](mailto:eurocus@bourns.com)

Asia-Pacific: Tel +886-2 256 241 17  
Email [asiacus@bourns.com](mailto:asiacus@bourns.com)

COPYRIGHT © 2024 • BOURNS, INC. • 3/24 • e/IC24026

"Bourns" is a registered trademark of Bourns, Inc. in the U.S. and other countries.