

## Features

- Formerly **FulTec** brand
- Extremely high speed performance
- Blocks high voltages and currents
- Low insertion loss
- Two TBU® protectors in one small package
- Very high bandwidth; GHz compatible
- RoHS compliant\*, UL Recognized



The P650-U & P850-U Series are currently available, but not recommended for new designs. Bourns® TBU-DT Series is preferred.

## P650-U and P850-U Series TBU® High-Speed Protectors

### Transient Blocking Units - TBU® Devices

Bourns® Model P650-U and P850-U products are high-speed, unidirectional protection components, constructed using MOSFET semiconductor technology, designed to protect against faults caused by short circuits, AC power cross, induction and lightning surges.

The TBU® high-speed protector, triggering as a function of the MOSFET, blocks surges and provides an effective barrier behind which sensitive electronics are not exposed to large voltages or currents during surge events. The TBU® device is provided in a surface mount DFN package and meets industry standard requirements such as RoHS and Pb Free solder reflow profiles.

### Agency Approval

UL recognized component File # E315805.

### Industry Standards

		Description	Model
Telcordia	GR-1089	Port Type 3, 5	P650-U
		Port Type 2, 4	P850-U
ITU-T		K.20, K.20E, K.21, K.21E, K.45	P850-U

### Absolute Maximum Ratings ( $T_{amb} = 25\text{ }^{\circ}\text{C}$ )

Symbol	Parameter		Value	Unit
$V_{imp}$	Maximum protection voltage for impulse faults with rise time $\geq 1\text{ }\mu\text{sec}$	P650-Uxxx-WH	650	V
		P850-Uxxx-WH	850	
$V_{rms}$	Maximum protection voltage for continuous $V_{rms}$ faults connected as a series pair (refer to page 3 Test Configuration Diagram)	P650-Uxxx-WH	300	V
		P850-Uxxx-WH	425	
$T_{op}$	Operating temperature range		-40 to +85	$^{\circ}\text{C}$
$T_{stg}$	Storage temperature range		-65 to +150	$^{\circ}\text{C}$

### Electrical Characteristics ( $T_{amb} = 25\text{ }^{\circ}\text{C}$ )

Symbol	Parameter		Min.	Typ.	Max.	Unit
$I_{op}$	Maximum current through the device that will not cause current blocking	P650-U180-WH			180	mA
		P650-U260-WH			260	
		P850-U180-WH			180	
		P850-U260-WH			260	
$I_{trigger}$	Typical current for the device to go from normal operating state to protected state	P650-U180-WH		220		mA
		P650-U260-WH		330		
		P850-U180-WH		220		
		P850-U260-WH		330		
$I_{out}$	Maximum current through the device	P650-U180-WH			360	mA
		P650-U260-WH			520	
		P850-U180-WH			360	
		P850-U260-WH			520	
$R_{device}$	Series resistance of the TBU® device	P650-Uxxx-WH		6	7	$\Omega$
		P850-Uxxx-WH		8	9	
$R_{bal}$	Line-to line series resistance difference between two TBU® devices				0.5	$\Omega$
$t_{block}$	Maximum time for the device to go from normal operating state to protected state	P650-Uxxx-WH P850-Uxxx-WH			1	$\mu\text{s}$
$I_{quiescent}$	Current through the triggered TBU® device with 50 Vdc circuit voltage			1		mA
$V_{reset}$	Voltage below which the triggered TBU® device will transition to normal operating state	P650-Uxxx-WH		11		V
		P850-Uxxx-WH		14		

The P-U Series TBU® devices are unidirectional; specifications are valid for input direction only. For the output direction, the TBU® device is a resistor.

\*RoHS Directive 2002/95/EC Jan. 27, 2003 including annex and RoHS Recast 2011/65/EU June 8, 2011. Specifications are subject to change without notice. Customers should verify actual device performance in their specific applications.

## Applications

- Mb Ethernet port protection
- Gb Ethernet port protection
- Isolated and floating interfaces

## P650-U and P850-U Series TBU® High-Speed Protectors

**BOURNS®**

### Typical Performance Characteristics

#### V-I Characteristics

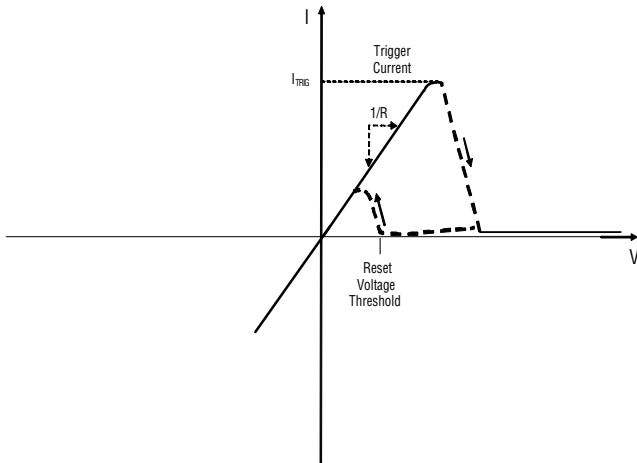

#### Time to Block vs. Fault Current

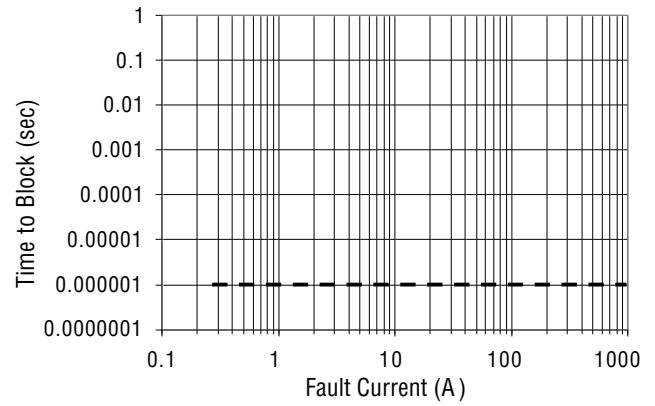

#### Trigger Current vs. Temperature

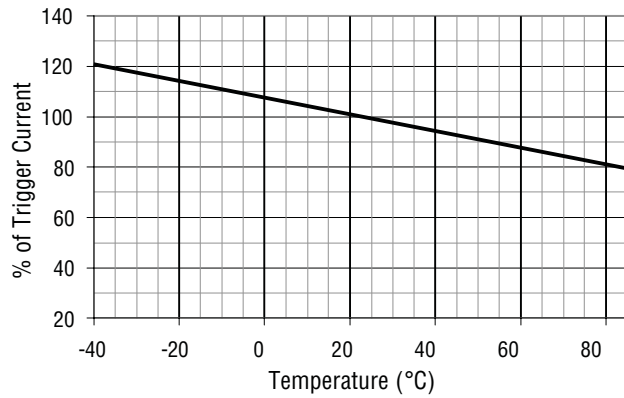

# P650-U and P850-U Series TBU® High-Speed Protectors

**BOURNS®**

## Operational Characteristics

The graphs below demonstrate the operational characteristics of the TBU® protector. For each graph the fault voltage, protected side voltage, and current is presented.

TEST CONFIGURATION DIAGRAM

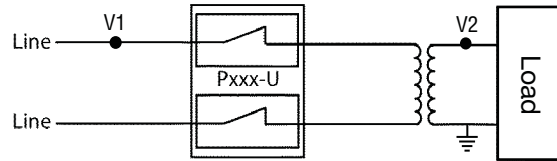

### P650-U Lightning, 650 V

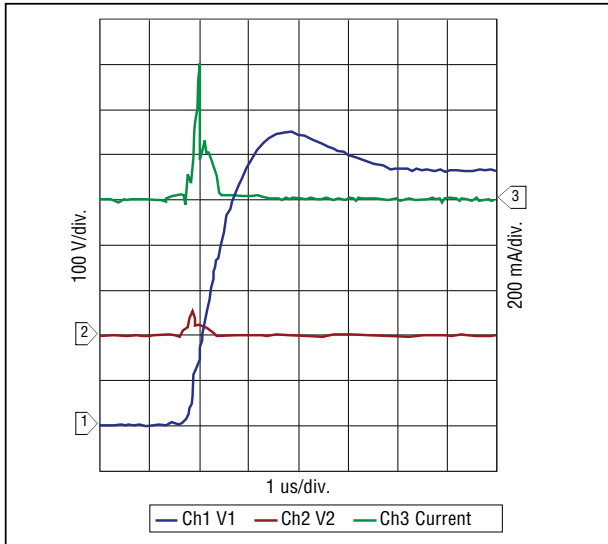

### P850-U Lightning, 850 V

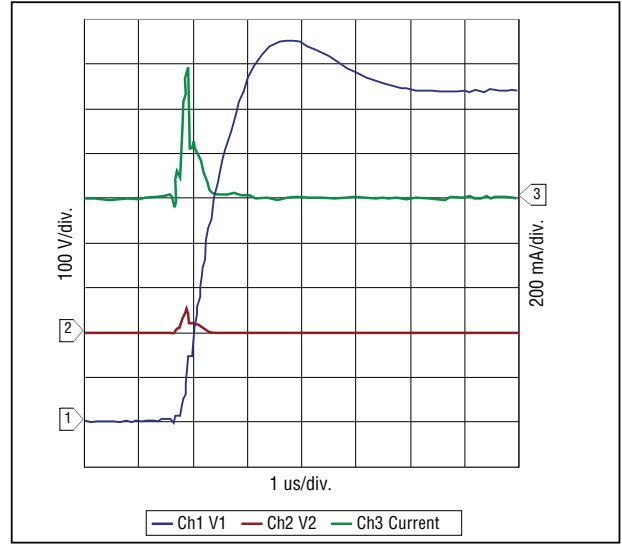

### P650-U Power Fault, 120 Vrms, 25 A

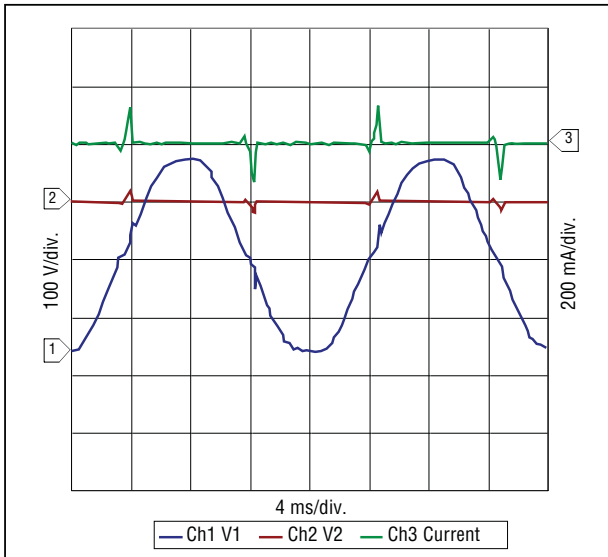

### P850-U Power Fault, 230 Vrms, 25 A

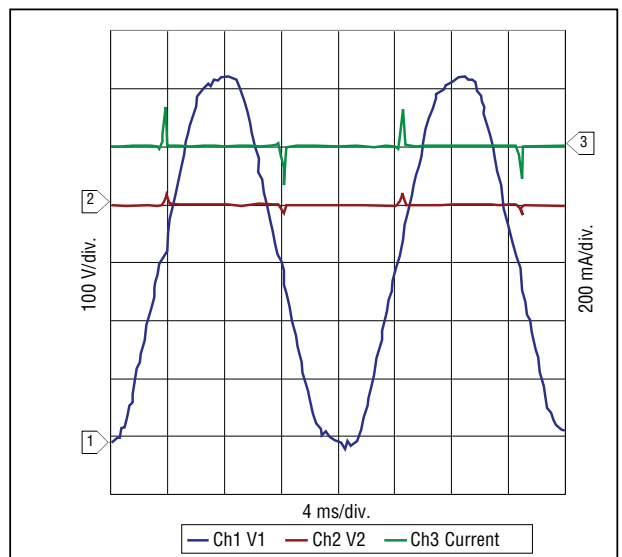

Specifications are subject to change without notice.  
Customers should verify actual device performance in their specific applications.

# P650-U and P850-U Series TBU® High-Speed Protectors

# BOURNS®

## Product Dimensions

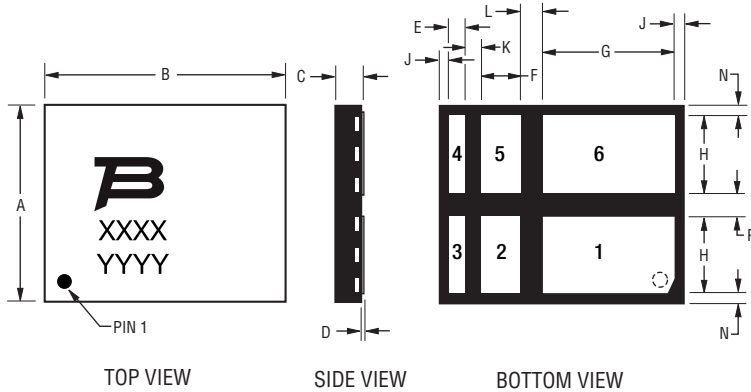

Dim.	Min.	Typ.	Max.
A	6.15 (.242)	6.25 (.246)	6.35 (.250)
B	7.65 (.301)	7.75 (.305)	7.85 (.309)
C	0.80 (.031)	0.85 (.033)	0.90 (.035)
D	0.000 (.000)	0.025 (.001)	0.050 (.002)
E	0.50 (.020)	0.55 (.022)	0.60 (.024)
F	1.20 (.047)	1.25 (.049)	1.30 (.051)
G	4.20 (.165)	4.25 (.167)	4.30 (.169)
H	2.45 (.096)	2.50 (.098)	2.55 (.100)
J	0.20 (.008)	0.25 (.010)	0.30 (.012)
K	0.45 (.018)	0.50 (.020)	0.55 (.022)
L	0.65 (.026)	0.70 (.028)	0.75 (.030)
N	0.20 (.008)	0.25 (.010)	0.30 (.012)
P	0.70 (.028)	0.75 (.030)	0.80 (.031)
Q	3.20 (.126)	3.25 (.128)	3.30 (.130)

## Recommended Pad Layout

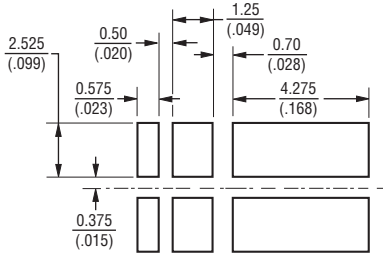

### Pad Designation

Pad #	Apply
1	In1
2	NC
3	Out1
4	Out2
5	NC
6	In2

NC = Solder to PCB; do not make electrical connection, do not connect to ground.

TBU® devices have matte-tin termination finish. Suggested layout should use non-solder mask define (NSMD). Recommended stencil thickness is 0.10-0.12 mm (.004-.005 in.) with stencil opening size 0.025 mm (.0010 in.) less than the device pad size. As when heat sinking any power device, it is recommended that, wherever possible, extra PCB copper area is allowed. For minimum parasitic capacitance, do not allow any signal, ground or power signals beneath any of the pads of the device.

DIMENSIONS:  $\frac{\text{MM}}{\text{(INCHES)}}$

## Thermal Resistances

Symbol	Parameter	Value	Unit
R <sub>th(j-a)</sub>	Junction to leads (package)	105	°C/W
	Junction to leads (per TBU® device)	202	°C/W

## Block Diagram

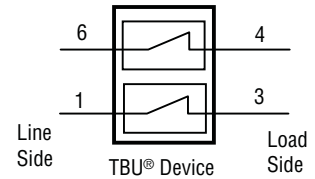

## Reflow Profile

Profile Feature	Pb-Free Assembly
Average Ramp-Up Rate (T <sub>smax</sub> to T <sub>p</sub> )	3 °C/sec. max.
Preheat	
- Temperature Min. (T <sub>smin</sub> )	150 °C
- Temperature Max. (T <sub>smax</sub> )	200 °C
- Time (t <sub>smin</sub> to t <sub>smax</sub> )	60-180 sec.
Time maintained above:	
- Temperature (T <sub>L</sub> )	217 °C
- Time (t <sub>L</sub> )	60-150 sec.
Peak/Classification Temperature (T <sub>p</sub> )	260 °C
Time within 5 °C of Actual Peak Temp. (t <sub>p</sub> )	20-40 sec.
Ramp-Down Rate	6 °C/sec. max.
Time 25 °C to Peak Temperature	8 min. max.

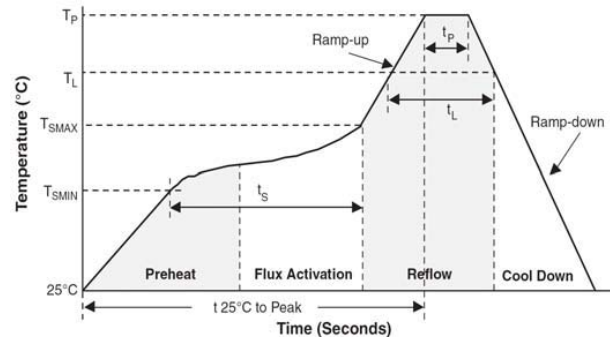

Specifications are subject to change without notice. Customers should verify actual device performance in their specific applications.

# P650-U and P850-U Series TBU® High-Speed Protectors

# BOURNS®

## How to Order

**P 650 - U 180 - WH**

Form Factor \_\_\_\_\_  
 P = Two TBU® protectors in one device

Impulse Voltage Rating \_\_\_\_\_  
 650 = 650 V  
 850 = 850 V

Directional Indication for Paired Devices \_\_\_\_\_  
 U = Unidirectional

Top Indicator \_\_\_\_\_  
 180 = 180 mA  
 260 = 260 mA

## Typical Part Marking

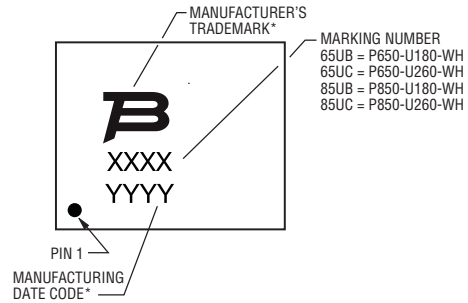

MANUFACTURING DATE CODE\*  
 - 1ST DIGIT INDICATES THE YEAR'S 6-MONTH PERIOD.  
 - 2ND DIGIT INDICATES THE WEEK NUMBER IN THE 6-MONTH PERIOD.  
 - 3RD & 4TH DIGITS INDICATE SPECIFIC LOT FOR THE WEEK.

6-MONTH PERIOD CODES:  
 A = JAN-JUN 2009    C = JAN-JUN 2010    E = JAN-JUN 2011  
 B = JUL-DEC 2009    D = JUL-DEC 2010    F = JUL-DEC 2011

EXAMPLE: ARBC  
 - 1ST DIGIT 'A' = JAN-JUN 2009  
 - 2ND DIGIT 'R' = WEEK 18; WEEK OF APRIL 27  
 - 3RD & 4TH DIGITS 'BC' = LOT SPECIFIC INFORMATION

\*TRANSITION FROM FULTEC TRADEMARK AND LOT CODE TO BOURNS TRADEMARK AND DATE CODE IN 2009.

## Packaging Specifications (per EIA468-B)

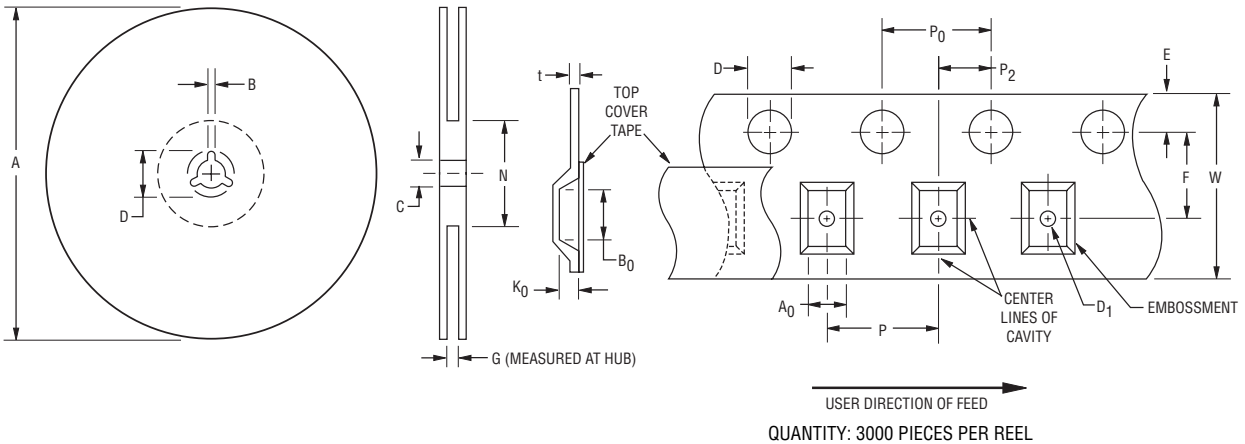

Device	A		B		C		D		G	N
	Min.	Max.	Min.	Max.	Min.	Max.	Min.	Max.	Ref.	Ref.
P650-U, P850-U	326 (.256)	330.25 (.264)	1.5 (.059)	2.5 (.098)	12.8 (.504)	13.5 (.531)	20.2 (.795)	-	16.5 (.650)	102 (4.016)

Device	A <sub>0</sub>		B <sub>0</sub>		D		D <sub>1</sub>		E		F	
	Min.	Max.	Min.	Max.	Min.	Max.	Min.	Max.	Min.	Max.	Min.	Max.
P650-U, P850-U	6.5 (.256)	6.7 (.264)	8.0 (.315)	8.2 (.323)	1.5 (.059)	1.6 (.063)	1.5 (.059)	-	1.65 (.065)	1.85 (.073)	7.4 (.291)	7.6 (.299)

Device	K <sub>0</sub>		P		P <sub>0</sub>		P <sub>2</sub>		t		W	
	Min.	Max.	Min.	Max.	Min.	Max.	Min.	Max.	Min.	Max.	Min.	Max.
P650-U, P850-U	1.4 (.055)	1.6 (.063)	11.9 (.469)	12.1 (.476)	3.9 (.159)	4.1 (.161)	1.9 (.075)	2.1 (.083)	0.25 (.010)	0.35 (.014)	15.7 (.618)	16.3 (.642)

Specifications are subject to change without notice.  
 Customers should verify actual device performance in their specific applications.

DIMENSIONS:  $\frac{\text{MM}}{\text{(INCHES)}}$

# P650-U and P850-U Series TBU® High-Speed Protectors



## Reference Applications

A cost-effective protection solution utilizes the Bourns® TBU® protection devices. The diagrams below illustrate common configurations of these components. The graph at the bottom demonstrates the operational characteristics of the circuit.

### Typical Configuration Diagrams

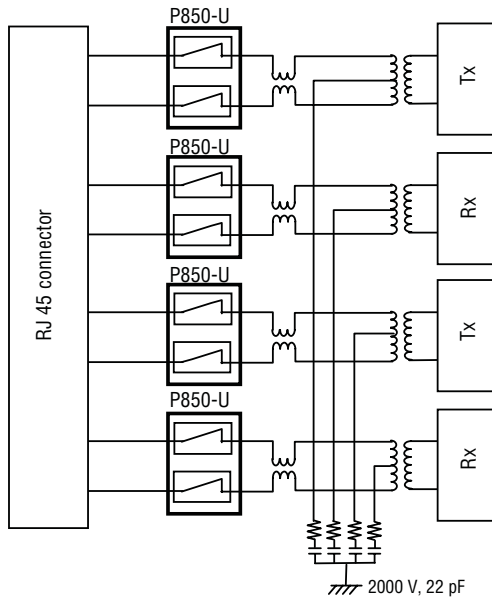

GbE Ethernet Protection  
Up to 1500 V Common-Mode Lightning Protection

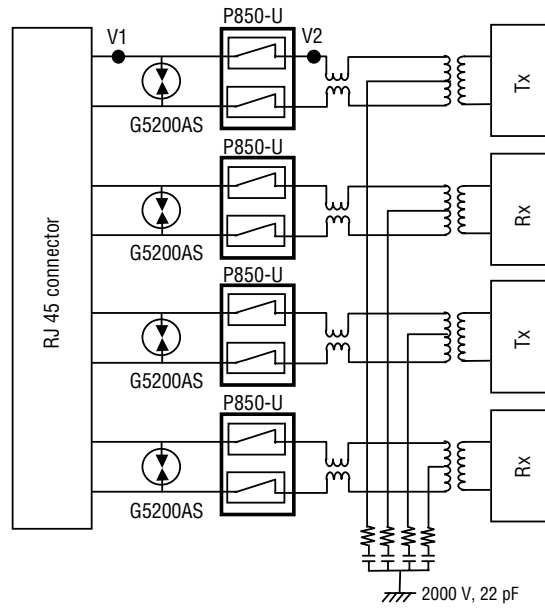

GbE Ethernet Protection  
Up to 6000 V Common-Mode Lightning Protection

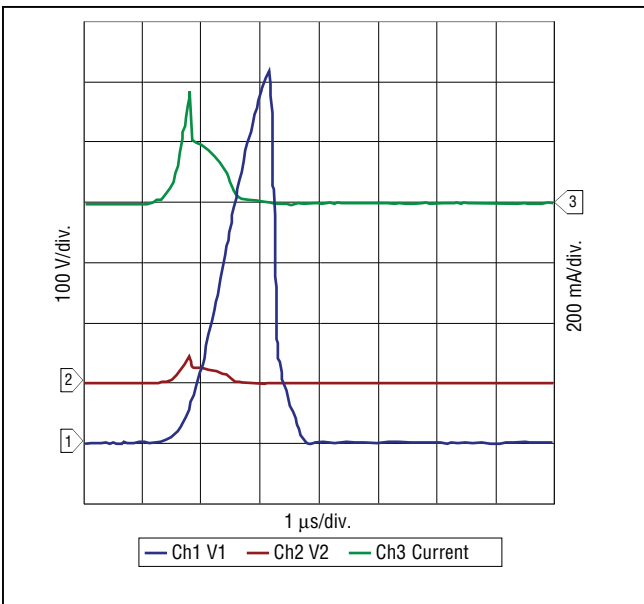

P850-U with G5200AS 4000 V Lightning 10/700 μsec, 150 A



Asia-Pacific: Tel: +886-2 2562-4117 • Fax: +886-2 2562-4116

Europe: Tel: +41-41 768 5555 • Fax: +41-41 768 5510

The Americas: Tel: +1-951 781-5500 • Fax: +1-951 781-5700

[www.bourns.com](http://www.bourns.com)

REV. 11/11

“TBU” is a registered trademark of Bourns, Inc. in the United States and other countries.

Specifications are subject to change without notice.

Customers should verify actual device performance in their specific applications.